

Construction of a New Artificial Pitch at Knocklyon Park

Screening for Appropriate Assessment

April 2023

Project number: 2022s0657

South Dublin County Council

A decorative graphic on the right side of the page, consisting of several overlapping, diagonal bands of parallel lines. The top band is blue, the middle band is light blue, and the bottom band is green. The lines are spaced evenly and create a sense of depth and movement.

JBA Project Manager

Patricia Byrne
 Unit 8, Block 660
 Greenogue Business Plaza
 Rathcoole
 Dublin
 D24 YN81

Revision History

Revision Ref / Date Issued	Amendments	Issued to
S3-P01 / 27 th April 2023	Draft Report	Jed McDermott
A3-C01/ 28th April 2023	Final Report	Jed McDermott

Contract

This report describes work commissioned by Jed McDermott of South Dublin County Council, by an email dated 16th of May 2022. Michael Coyle of JBA Consulting carried out this work.

Prepared by Michael Coyle, BA (Hons), MSc
 Assistant Ecologist

Reviewed by Patricia Byrne BSc (Hons) PhD MCIEEM
 Senior Ecologist

Purpose

This document has been prepared as a Final Report for South Dublin County Council. JBA Consulting accepts no responsibility or liability for any use that is made of this document other than by South Dublin County Council for the purposes for which it was originally commissioned and prepared.

JBA Consulting has no liability regarding the use of this report except to South Dublin County Council.

Copyright

© JBA Consulting Engineers and Scientists Limited 2023

Carbon Footprint

A printed copy of the main text in this document will result in a carbon footprint of 198g if 100% post-consumer recycled paper is used and 252g if primary-source paper is used. These figures assume the report is printed in black and white on A4 paper and in duplex.

JBA is aiming to reduce its per capita carbon emissions.

Contents

1	Introduction	1
1.1	Background	1
1.2	Legislative Context.....	1
1.3	Appropriate Assessment Process	1
1.4	Methodology.....	3
2	Project Description.....	7
2.1	The 'Project'	7
2.2	Site Location	7
2.3	Proposed Project.....	7
2.4	Zone of Influence (Zol).....	8
3	Existing Environment	9
3.1	Baseline conditions	9
3.2	Habitats	9
3.3	Waterbodies within the Vicinity of the Proposed Site	16
3.4	Groundwater	18
4	Natura 2000 Sites	20
5	Other Relevant Plans and Projects	25
5.1	Cumulative Effects	25
5.2	Plans.....	25
5.3	Other Projects	26
5.4	Summary.....	26
6	Screening Assessment.....	27
6.1	Introduction	27
6.2	Assessment Criteria	27
6.3	Concluding Statement.....	33
	Appendices	I
A	Site Layout Plan.....	I
B	Site Drainage Plan.....	II
C	Habitat Map	III
D	National Biodiversity Data Centre (2023)	IV
	References.....	VI

List of Figures

Figure 1-1: The Appropriate Assessment Process (from: Appropriate Assessment of Plans and Projects in Ireland - Guidance for Planning Authorities, DEHLG, 2009)....	2
Figure 1-2: Flow diagram of process for in-combination assessment (modified from Tyldesley and Chapman, 2013)	5
Figure 2-1: Site location and boundary of work (© OpenStreetMap contributors, 2023) ...	7
Figure 3-1: Habitat Map (© OpenStreetMap contributors, 2023)	10
Figure 3-2: The amenity grassland	11
Figure 3-3: The dry meadow grassland located in the east of the site.....	11
Figure 3-4: Mixed broadleaved woodland in the north of the site.....	12
Figure 3-5: Area of scattered trees located between the GAA pitches and the car park ...	12
Figure 3-6: Location of Flora of Interest within the site (© OpenStreetMap contributors, 2023)	14
Figure 3-7: Local river waterbodies (© OpenStreetMap contributors, 2023).....	17
Figure 3-8: Riverrine connections from site to Dublin Bay (© OpenStreetMap contributors, 2023)	17
Figure 3-9: Groundwater bodies in the vicinity of site (© OpenStreetMap contributors, 2023)	18
Figure 3-10: Aquifer vulnerability of the site (© OpenStreetMap contributors, 2023)	19
Figure 4-1: Natura 2000 sites within the 5km Zol and extended 15km hydrological connection (© OpenStreetMap contributors, 2023)	21
Figure 6-1: WFD sub-catchment of the surrounding area, and hydrological connection of the project site (© OpenStreetMap contributors, 2023)	28
Figure 6-2: Groundwater bodies around the proposed site in respect to Natura 2000 sites (© OpenStreetMap contributors, 2023)	29

List of Tables

Table 3-1: Habitats present on site.....	9
Table 3-2: Bird species encountered during Bird Surveys	14
Table 3-3: WFD status and risk of local watercourses.	16
Table 4-1: Natura 2000 sites located within the Zone of Influence (Zol) of the proposed development.....	20
Table 4-2: Site briefs; Qualifying Interests; and project-relevant threats /pressures and their impacts and sources in relation to the Natura 2000 sites within the 5km Zol (including hydrological connectivity extension).	22

Abbreviations

AA	Appropriate Assessment
CJEU	Court of Justice of the European Union
CIEEM	Chartered Institute of Ecology and Environmental Management
DoEHLG	Department of Environment, Heritage and Local Government
EC	European Communities
EPA	Environmental Protection Agency
EU	European Union
GSI	Geological Survey Ireland
INNS	Invasive Non-native Species
IROPI	Imperative Reasons of Over-riding Public Interest
NBDC	National Biodiversity Data Centre
NO _x	Nitrogen Oxides
NPWS	National Parks and Wildlife Service
OPR	Office of the Planning Regulator
QI	Qualifying Interest
RBMP	River Basin Management Plan
SAC	Special Area of Conservation
SDCC	South Dublin County Council
SPA	Special Protection Area
WFD	Water Framework Directive
WWTP	Waste Water Treatment Plant
Zol	Zone of Influence

1 Introduction

1.1 Background

JBA Consulting Engineers and Scientists Ltd. (hereafter JBA) has been commissioned by South Dublin County Council (SDCC) to prepare an Appropriate Assessment Screening Report for the proposed establishment of an artificial pitch in Knocklyon GAA Pitches, Co. Dublin.

Screening for appropriate assessment is intended to be an initial examination which must be carried out by the Planning Authority or An Bord Pleanála as the competent authority. However, this screening is completed on behalf of the project proposer to show that likely significant effects have been considered in the project development and design, and where necessary progress with further assessment.

1.2 Legislative Context

Directive 92/43/EEC on the Conservation of Natural Habitats and Wild Fauna and Flora, known as the 'Habitats Directive' - provides legal protection for habitats and species of European importance. Article 2 of the Directive requires the maintenance or restoration of habitats and species of European Community interest, at a favourable conservation status. Articles 3 - 9 provide the legislative means to protect habitats and species of Community interest through the establishment and conservation of an EU-wide network of sites known as Natura 2000 sites. Natura 2000 sites are Special Areas of Conservation (SACs) designated under the Habitats Directive and Special Protection Areas (SPAs) designated under the Conservation of Wild Birds Directive (79 / 409 / EEC).

Articles 6(3) and 6(4) of the Habitats Directive set out the decision-making tests for plans or projects affecting Natura 2000 sites. Article 6(3) establishes the requirement for Appropriate Assessment:

"Any plan or project not directly connected with or necessary to the management of the site but likely to have a significant effect thereon, either individually or in combination with other plans or projects, shall be subject to appropriate assessment of its implications for the site in view of the site's conservation objectives. In the light of the conclusions of the assessment of the implications for the site and subject to the provisions of paragraph 4, the competent national authorities shall agree to the plan or project only after having ascertained that it will not adversely affect the integrity of the site concerned and, if appropriate, after having obtained the opinion of the general public."

Article 6(4) deals with the steps that should be taken when it is determined, as a result of Appropriate Assessment, that a plan/project will adversely affect a European site. Issues dealing with alternative solutions, imperative reasons of overriding public interest and compensatory measures need to be addressed in this case.

Article 6(4) states:

"If, in spite of a negative assessment of the implications for the site and in the absence of alternative solutions, a plan or project must nevertheless be carried out for imperative reasons of overriding public interest, including those of a social or economic nature, the Member States shall take all compensatory measures necessary to ensure that the overall coherence of Natura 2000 is protected. It shall inform the Commission of the compensatory measures adopted."

Where the site concerned hosts a priority natural habitat type and / or a priority species, the only considerations which may be raised are those relating to human health or public safety, to beneficial consequences of primary importance for the environment or, further to an opinion from the Commission, to other imperative reasons of overriding public interest."

The requirements of Articles 6(3) and 6(4) of the Habitats Directive have been transposed into Irish legislation by means of *inter alia* the European Communities (Birds and Natural Habitats) Regulations 2011-2015 (S.I. No. 477 / 2011) as amended.

1.3 Appropriate Assessment Process

Guidance on the Appropriate Assessment (AA) process was produced by the European Commission in 2002, which was subsequently developed into guidance specifically for Ireland by the Department of Environment, Heritage and Local Government (DEHLG) (2009, rev 2010). Office of the Planning Regulator (OPR) produced a Practice Note in 2021, PN01 - Appropriate Assessment Screening for

Development Management (OPR, 2021). These guidance documents identify a staged approach to conducting an AA, as shown Figure 1-1.

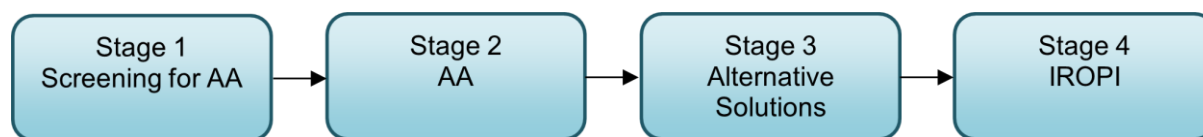

Figure 1-1: The Appropriate Assessment Process (from: Appropriate Assessment of Plans and Projects in Ireland - Guidance for Planning Authorities, DEHLG, 2009)

1.3.1 Stage 1 - Screening for AA

The initial, screening stage of the Appropriate Assessment is to determine:

- whether the proposed plan or project is directly connected with or necessary for the management of the European designated site for nature conservation
- if it is likely to have a significant adverse effect on the European designated site, either individually or in combination with other plans or projects.

For those sites where, potential adverse impacts are identified, either alone or in combination with other plans or projects, further assessment is necessary to determine if the proposals will have an adverse impact on the integrity of a European designated site, in view of the site's conservation objectives (i.e. the process proceeds to Stage 2).

1.3.2 Stage 2 - AA

This stage requires a more in-depth evaluation of the plan or project, and the potential direct and indirect impacts of them on the integrity and interest features of the European designated site(s), alone and in combination with other plans and projects, taking into account the site's structure, function and conservation objectives. Where required, mitigation or avoidance measures will be suggested.

The competent authority can only agree to the plan or project after having ascertained that it will not adversely affect the integrity of the site(s) concerned. If this cannot be determined, and where mitigation cannot be achieved, then alternative solutions will need to be considered (i.e. the process proceeds to Stage 3).

1.3.3 Stage 3 - Alternative Solutions

Where adverse impacts on the integrity of Natura 2000 sites are identified, and mitigation cannot be satisfactorily implemented, alternative ways of achieving the objectives of the plan or project that avoid adverse impacts need to be considered. If none can be found, the process proceeds to Stage 4.

1.3.4 Stage 4 - IROPI

Where adverse impacts of a plan or project on the integrity of Natura 2000 sites are identified and no alternative solutions exist, the plan will only be allowed to progress if imperative reasons of overriding public interest can be demonstrated. In this case compensatory measures will be required.

The process only proceeds through each of the four stages for certain plans or projects. For example, for a plan or project, not connected with management of a site, but where no likely significant impacts are identified, the process stops at stage 1. Throughout the process, the precautionary principle must be applied, so that any uncertainties do not result in adverse impacts on a site.

This report is in support of a Stage 1 Screening for Appropriate Assessment.

1.3.5 Recent judgements of the Court of Justice of the European Union (CJEU) and how they are used in this assessment

The CJEU issued a ruling on the consideration of avoidance and reduction measures as a result of the case known as *People over Wind, Peter Sweetman v Coillte Teoranta* (Case C-323/17). This judgement stated that measures intended to reduce or avoid effects on a Natura 2000 site should only be considered within the framework of an Appropriate Assessment, and it is not permissible to take into account such measures at the screening stage. In practice, this means that any activities that are not

integral to the project (i.e., the project could conceivably take place without them) and have the effect of avoiding or reducing an impact on a Natura 2000 site, cannot be considered at the screening stage.

The CJEU ruling in the case of *Grace & Sweetman* [2018] (C-164/17) clarified the difference between avoidance and reduction (mitigation) measures and compensation. Measures intended to compensate for the negative effects of a project cannot be taken into account in the assessment of the implications of a project, and instead are considered under Article 6(4). This means that any project where an effect on the integrity of a Natura 2000 site remains and can only be offset by compensation, would need to proceed under Article 6(4), demonstrating “imperative reasons of overriding public interest”.

The judgements referred to as the Dutch Nitrogen cases [2018] (C-293/17 and C-294/17) have important implications for projects that could potentially impact on sites that are exceeding critical thresholds for input of damaging ammonia (but could also reasonably apply where other nutrients are impacting Natura 2000 sites). The judgements state that the use of thresholds to exclude project impacts is acceptable in principle, and that strategic plans can be used as mitigation but only with consideration of the certainty (or otherwise) of the outcomes of those strategic plans. It clarifies that where the status of a habitat type is already unfavourable the possibility of authorising activities which increase the problem is necessarily limited.

The CJEU ruling in the case of *Holohan v An Bord Pleanála* (C-462/17) also clarified the importance in Appropriate Assessment of taking into account habitat types and species outside the boundary of the Natura 2000 site where implications of the impacts on those habitat and species may impact the conservation objectives of the Natura 2000 site. In this assessment functionally linked and supporting habitat for species outside of Natura 2000 sites are assessed where they could potentially impact the conservation objectives of any screened in Natura 2000 sites.

1.4 Methodology

The Screening for Appropriate Assessment has been prepared having regard to the Birds and Habitats Directives, the European Communities (Birds and Natural Habitats) Regulations 2011-15 as amended and relevant jurisprudence of the EU and Irish courts. The following documents have also been used to provide guidance for the assessment:

- DEHLG (2009 rev 2010) Appropriate Assessment of Plans and Projects in Ireland Guidance for Planning Authorities. Department of the Environment, Heritage and Local Government (DEHLG, 2009).
- Office of the Planning Regulator (2021) OPR Practice Note PN01 - Appropriate Assessment Screening for Development Management (OPR, 2021).
- European Communities (EC) (2018) Managing Natura 2000 Sites: the provisions of Article 6 of the 'Habitats' Directive 92/43/EEC, Office for Official Publications of the European Communities, Luxembourg. European Commission (European Commission, 2000).
- EC (2002) Assessment of Plans and Projects Significantly Affecting Natura 2000 Sites: Methodological guidance on the provisions of Article 6(3) and (4) of the Habitats Directive 92/43/EEC, Office for Official Publications of the European Communities, Luxembourg. European Commission (European Commission et al., 2002), and 2021 update (EC 2021).
- EC (2007) Guidance document on Article 6(4) of the 'Habitats Directive' 92/43/EEC – Clarification of the concepts of: alternative solutions, imperative reasons of overriding public interest, compensatory measures, overall coherence, opinion of the commission. European Commission Management (European Commission, 2007).
- EC (2021) Assessment of plans and projects in relation to Natura 2000 sites - Methodological guidance on Article 6(3) and (4) of the Habitats Directive 92/43/EEC. (European Commission 2021)

1.4.1 Desktop study

A desktop study was conducted of available published and unpublished information, along with a review of data available on the National Parks and Wildlife Service (NPWS) and National Biodiversity Data Centre (NBDC) web-based databases, in order to identify key habitats and species (including legally protected and species of conservation concern) that may be present within ecologically relevant distances from the project as explained below. The data sources below were consulted for the desktop study:

- Aerial photography available from www.osi.ie and Esri World Imagery.
- NPWS website (www.npws.ie) where Natura 2000 site synopses, data forms and conservation objectives were obtained along with Annex I habitat distribution data and status reports.
- River Basin Management Plans (www.wfdireland.ie)
- NBDC Biodiversity Maps (maps.biodiversityireland.ie)
- Catchments (www.catchments.ie)
- Environmental Protection Agency Maps (<https://gis.epa.ie/EPAMaps>)
- Geological Survey Ireland (GSI) website (www.gsi.ie)
- GSI - Groundwater data viewer (<https://dcenr.maps.arcgis.com>)
- Planning Applications (myplan.ie)

1.4.2 Ecological Site Survey

To inform this AA Screening, a general ecological site walkover, including a habitat mapping survey, was conducted on the 9th of June 2022 by Patricia Byrne, Mark Desmond and Michael Coyle of JBA Consulting to inform the ecological baseline of the site. Bat Transect surveys were conducted on the 4th of July, 28th of July and 31st of August by JBA Ecologists, a Pollinator survey was conducted on the 4th of August 2022 and wintering bird surveys were conducted from November 2022 to March 2023.

The ecological walkover survey recorded habitats and protected species, following the methods outlined in the documents below:

- Heritage Council (2011). Best Practice Guidance for Habitat Survey and Mapping (Smith et al. 2011).
- Ecological Surveying Techniques for Protected Flora and Fauna during the Planning of National Road Schemes (NRA, 2009).

Aerial photographs and site maps assisted the survey. Habitats have been classified and described following Fossitt (2000). Nomenclature for higher plants follows that given in The New Flora of the British Isles 4th Edition (Clive Stace, 2019). Identification of Irish plants generally follows Webb's An Irish Flora (Parnell and Curtis, 2012).

1.4.3 In-combination Assessment

The in-combination assessment followed the process for in-combination set out by the DTA Handbook (Tyldesley and Chapman, 2013). The in-combination impacts are considered only after the assessment of the project alone. If the result of this is that the project will have no effect at all on a European site then no in-combination assessment would be necessary. However, where there is no adverse effect on site integrity, but some adverse effect an assessment of this adverse effect in-combination with other plans or projects is carried out. Other plans or projects were searched for using the National Planning Application Database, EIA portal and Myplan.ie databases all accessed online. If no other plans or projects are identified, then the assessment is complete. Where other plans or projects are identified then initially a review is made of its AA screening, or AA, and if the Competent Authority for the plan or project has made a final determination of no effect on the integrity of any European site, either alone or in-combination, this determination is used in this assessment. Where there is not a full AA, or the findings are unclear or out of date, the plan or project documentation is checked for credible evidence of real (not hypothetical) risk to a European site. Where these are identified then a detailed assessment is carried out. A summary of the approach is presented in Figure 1-2.

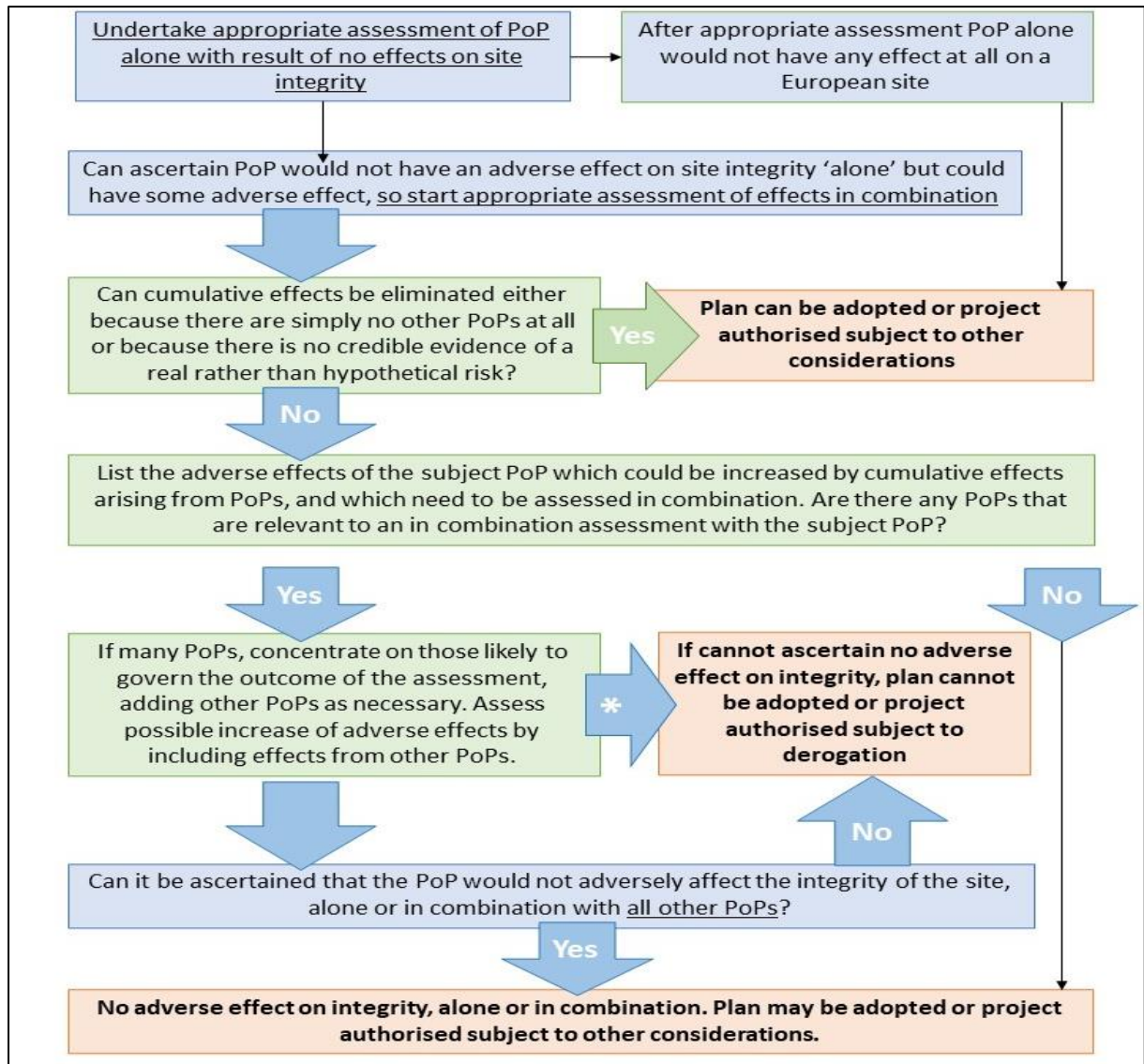

Figure 1-2: Flow diagram of process for in-combination assessment (modified from Tyldesley and Chapman, 2013)

Potential sources of cumulative impacts were identified based on the ecology of valued ecological features only for features where this is a residual or non-significant impact. Potential sources of cumulative impacts were sought within an area where there is the potential for a significant impact on relevant Natura sites identified in Section 4.

1.4.4 Limitations and constraints

The screening assessment necessarily relies on some assumptions, and it was inevitably subject to some limitations. These would not affect the conclusion, but the following points are recorded in order to ensure the basis of the assessment is clear:

- Information on the site is based on current knowledge from desk top review, as well as information gained from the latest site visit. However, the initial site visit and habitat mapping took place on the 9th of June 2022, and it is possible that features and information regarding the site may have since changed.
- This assessment is based on the methodology for proposed works as described in this report. Where changes to methodology occur, an ecologist will need to be consulted to determine if the changes are likely to alter the ecological impacts and would therefore need reassessment.

2 Project Description

2.1 The 'Project'

The Proposed Project is not directly connected with, or necessary to the management of any Natura 2000 site and may have potential adverse impacts upon the Natura 2000 sites identified in Section 4. Therefore, the proposed project is subject to the requirements of the AA process.

2.2 Site Location

The proposed project is located in Knocklyon Park, adjacent to Woodstown Green housing estate, and approximately 90m south-west of the M50 in Knocklyon, Co. Dublin (Figure 2-1). The Woodstown Stream is located approximately 65m south-east of the site, along the boundary of the parkland. This stream flows east into the River Owenadoher before flowing north towards the main body of the River Dodder. Nearby, to the west of the site, is a culverted section of the Orlagh River (Dodder_040).

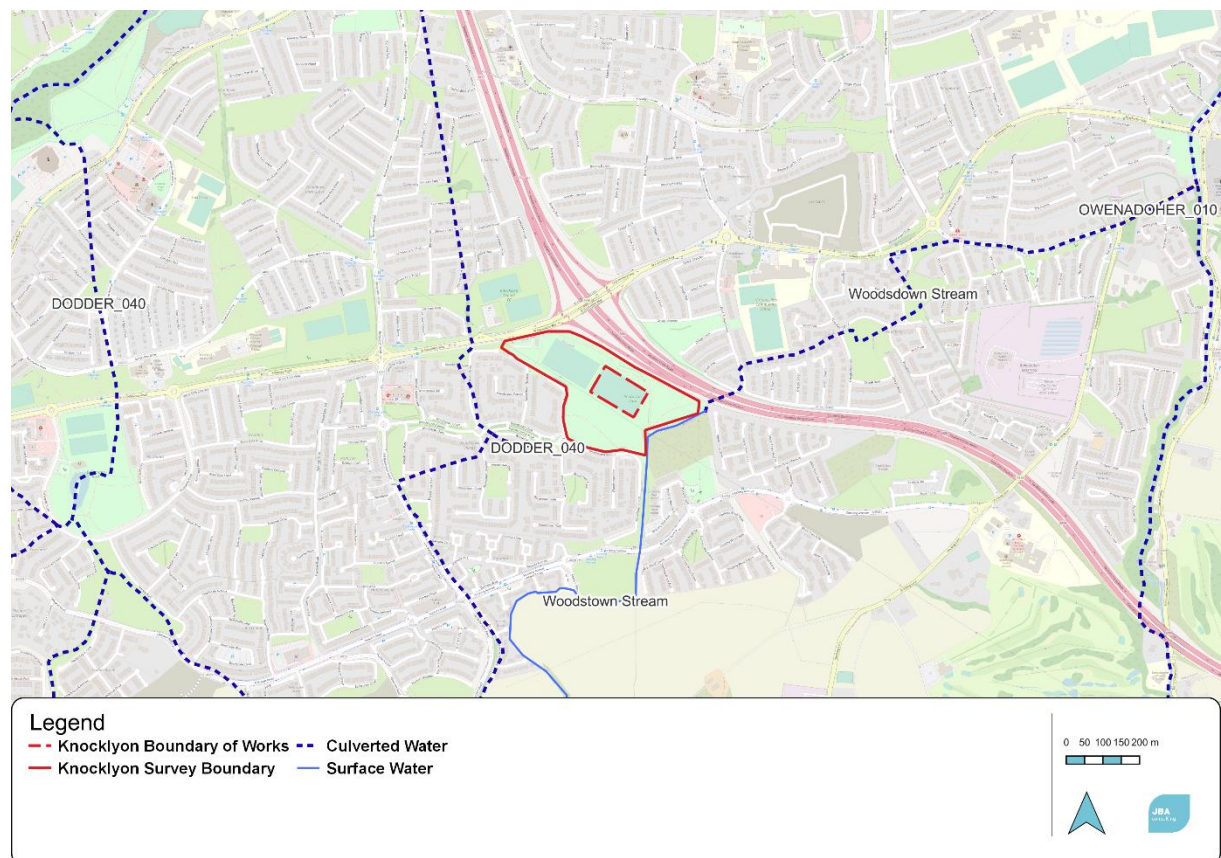

Figure 2-1: Site location and boundary of work (© OpenStreetMap contributors, 2023)

2.3 Proposed Project

South Dublin County Council (SDCC). intend to apply for permission for the proposed construction of an artificial pitch in Knocklyon GAA Pitches, Co. Dublin.

The development will consist of the construction of an 11,433m² artificial pitch with 3G Synthetic Turf, to be primarily used for full sized soccer, GAA and Rugby with line markings for cross-field play as an option in the future. The facility would be completed with an access route, spectator area, fencing and netting, floodlighting and equipment. The artificial pitch will be surrounded by a kickboard of approximately 2.5cm height, a fence height of 640cm that will each be embedded into 300mm³ of concrete, and six floodlighting columns.

- The additional scope of the works include:
- Apply fertiliser to proposed grass development area.

- Excavate and remove all topsoil's over the grassed development area (thickness TBC conjectured at 250mm)
- Earthworks cut and fill to new formation
- Apply separator membrane and geogrid system on formation.
- Installation of parallel drainage network completion with carrier drainage and cut off drain as required, to form a new outfall or attenuation tank as necessary.
- Install new internal perimeter kerbing. - Installation of crushed stone sub-base including any blinding layer 300 mm.
- Installation of engineered base layer (porous 40mm minimum)
- Installation of new 5m high perimeter fencing with an increased 10m minimum ball stop nets behind both GAA goals.
- Installation of new 6-column floodlighting system
- Installation of new spectator area including new 1.2m spectator guard rail.
- Installation of new prefabricated shockpad.
- Installation of detox area including a brush-down station
- New 60mm 3G synthetic turf, complete with infill and line markings cut in/in laid.
- Landscaping and reinstatement of surrounding area

Surface water that accumulates on the pitches will be fed through a lateral drainage system that will feed into a carrier drainage section before entering a silt trap chamber and a soakaway. The lateral drain and carrier drain sections will both consist of a 6-10mm gravel backfill and a 10-20mm Type B gravel bedding, while the drains will be made of a 150mm Ø and 80mm Ø perforated twin wall uPVC pipe respectively, while the carrier drain will also contain a geotextile membrane.

The Proposed Project is scheduled to last for approximately 6 months.

These details can be seen in the Site Layout Plan which can be viewed in Appendix A, and Drainage Plan, which can be viewed in Appendix B.

2.4 Zone of Influence (Zoi)

The project will primarily affect the site only, but a wider area of influence is used for impacts relating to noise disturbance (1km), air (2km), groundwater pollution (5km), surface water (5km), and an additional hydrological buffer from connecting transitional waters to coastal areas (15km); and any supporting habitat for SAC/SPA species (e.g. wintering birds) within the vicinity of the site (15km).

3 Existing Environment

3.1 Baseline conditions

The proposed development of the new synthetic sports pitch is located within Knocklyon GAA pitch, set within an urban environment. The site currently contains some amenity sports pitches, with a boundary of woodlands and sections of meadow grassland south of the pitches. The site is located approximately 65m north-west of the closest surface waterbody, Woodstown Stream.

3.2 Habitats

The site is located within Knocklyon GAA Pitches, with housing estates located along the west and south boundary, and the M50 is located approximately 90m north-east of the site. The site itself is primarily composed of amenity grassland, with a northern boundary of hedgerows and scrub, and some sections of meadow grassland and woodlands along the east and southern boundary of the site.

A baseline ecological site walkover, including habitat mapping, was conducted by JBA Ecologist, Patricia Byrne, Mark Desmond and Michael Coyle on the 9th of June 2022. Habitats recorded are listed in Table 3-1 and an overview of habitats is shown in Figure 3-1. Habitats and species recorded are presented in detail in the following sections.

Table 3-1: Habitats present on site

Fossitt Habitat	Fossitt Code
Buildings and artificial surfaces	BL3
Amenity grassland (improved)	GA2
Dry meadows and grassy verges	GS2
Dry meadows and grassy verges/Scrub	GS2/WS1
Depositing/lowland rivers	FW2
(Mixed) broadleaved woodland	WD1
Mixed broadleaved/conifer woodland	WD2
Scattered trees and parkland	WD5
Hedgerows	WL1
Treelines	WL2
Scrub	WS1
Immature woodland	WS2
Ornamental/non-native shrub	WS3

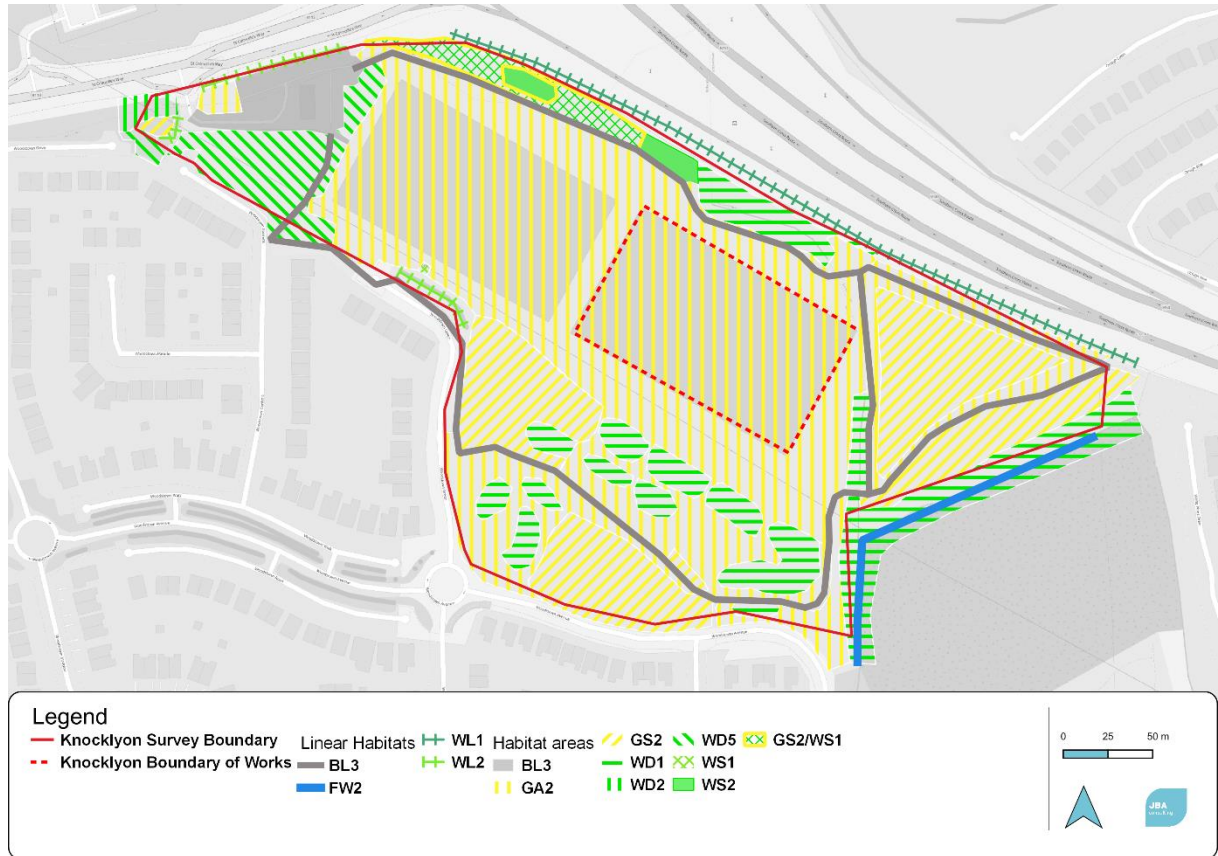

Figure 3-1: Habitat Map (© OpenStreetMap contributors, 2023)

3.2.1 BL3 - Buildings and artificial Surfaces

There are pathways located around throughout the boundary of the survey area. Additionally, there is also the car park and facilities buildings for GAA pitches located in the west of the site. There are no species present in these areas.

3.2.2 GA2 - Amenity grassland (improved)

There is a large area in the centre of the survey area, which is currently dedicated to sports pitches and amenity grassland and there are also sections of amenity grassland along the pathways in the south of the area. The species within these grassland areas include Red Clover *Trifolium pratense*, White Clover *Trifolium repens*, Dandelion *Taraxacum* spp., Creeping Buttercup *Ranunculus repens*, Meadow Buttercup *Ranunculus acris*, Silver Plantain *Plantago lanceolata*, Daisy *Bellis perennis*, Common Bent *Agrostis capillaris*, Red Fescue *Festuca rubra*, Thistle *Cirsium vulgare*, Hedge Mustard *Sisymbrium officinale*, Herb Robert *Geranium robertianum* and Perennial Ryegrass *Lolium perenne*.



Figure 3-2: The amenity grassland

3.2.3 GS2 - Dry meadows and grassy verges

There are sections of a dry meadow located in the east, south and within a small section of the north of the survey area (Figure 3-3). The species within these areas include White Clover, Dandelion, Cluster Dock *Rumex conglomeratus*, Hogweed *Heracleum sphondylium*, Meadow Buttercup, Creeping Buttercup, Common Bent, Couch *Elytrigia repens*, Wild Garlic *Allium ursinum*, Silver Plantain, Wild Sage *Salvia officinalis*, Cuckooflower *Cardamine pratensis*, Red Fescue, Meadow Fescue *Festuca pratensis*, Yorkshire Fog *Holcus lanatus*, Yellow Oatgrass *Trisetum flavescens*, Soft Brome *Bromus hordeaceus* and within the north meadow section there was a Square Stalked St John's Wort *Hypericum tetrapterum*.



Figure 3-3: The dry meadow grassland located in the east of the site

3.2.4 GS2/WS1 - Dry meadows and grassy verges / Scrub

There is a length of Scrub that is located in the north of the site, which contains small outer belt of meadow grassland. The Scrub vegetation of this area contains Bramble *Rubus fruticosus* agg., some Rose *Rosa* spp. occasional newly planted Apple trees *Malus* spp., Scots Pine *Pinus sylvestris*, Dock *Rumex* spp., Thistle and Alexander's *Smyrnium olusatrum*. The boundary of the scrub has a belt of dry meadow species with Red Clover, Meadow Buttercup, Hedge Mustard and Shepherds Purse *Capsella bursa-pastoris*.

3.2.5 FW2 - Depositing/lowland rivers

Woodstown Stream is located in the eastern section of the site, flowing through the woodland habitat. There were no species noted within this stream.

3.2.6 WD1 - (Mixed) broadleaved woodland

There are some smaller pockets of broadleaved woodland along the north boundary of the site (Figure 3-4) and throughout the south of the site, and an additional stretch of mature broadleaved woodland in the east of the site. The tree species within the pockets of woodland include Sycamores *Acer pseudoplatanus*, Ash *Fraxinus excelsior* (some with, and some without Dieback), Hawthorn *Crataegus monogyna*, Blackthorn *Prunus spinosa*, Silver Birch *Betula pubescens*, Wild Cherry *Prunus avium*, Lime *Tilia cordata x platyphyllos*, Elder *Sambucus nigra*, and some of these trees have a cover of Ivy *Hedera helix* on them. The shrub and ground layer within these woodland pockets include Bramble, *Rosa* spp., Hogweed, Nettle *Urtica dioica*, Bush Vetch *Vicia sepium*, Thistle, Cut-leaved Crane's-bill *Geranium dissectum*, Red Valerian *Centranthus ruber*, Creeping Buttercup, Petty Spurge *Euphorbia peplus*, Cow Parsley *Anthriscus sylvestris*, Daisy, Cock's Foot *Dactylis glomerata*, Shepherd's Purse and False Brome *Brachypodium sylvaticum*.

The strip of woodland in the east of the site includes Ash, Beech *Fagus sylvatica*, Hawthorn, Oak *Quercus* spp., Honeysuckle *Lonicera periclymenum*, and one Irish Whitebeam *Sorbus hibernica* was noted within this woodland area.



Figure 3-4: Mixed broadleaved woodland in the north of the site

3.2.7 WD2 - Mixed broadleaved/conifer woodland

There is a small section of a mixture of broadleaved and conifer woodland that is located in the west of the site. The tree species in this area include Wild Cherry, Ash, Scots Pine, Sycamore and Lime, with an understory of Herb Robert, Dandelion, Alexander's, Cleavers *Gallium aparine* and Nettle.

3.2.8 WD5 - Scattered trees and parkland

Within the west of the survey area, near to the GAA facilities and car park (Figure 3-5), are areas of scattered trees and parkland. The trees in this area include Oak, Scot's Pine, Beech, Wild Cherry, Sycamore, Horse Chestnut *Aesculus hippocastanum* and Lime, with a ground cover of continued species from the amenity grassland including Dandelion, Creeping Buttercup, Meadow Buttercup, Silver Plantain, Daisy and Perennial Ryegrass.



Figure 3-5: Area of scattered trees located between the GAA pitches and the car park

3.2.9 WL1-Hedgerows

There is a hedgerow located outside the northern boundary of the survey area. The species within this hedgerow include Hawthorn, Ash, Elder, Field Maple *Acer campestre* and Lime, Honeysuckle,

Sycamore saplings, young Scots Pine, Alder, Oak, *Rosa* spp. and a low diversity understory of Bramble, Clover, Dandelion, mixed grass, Cleavers, some Willowherb *Epilobium* spp. in places, and some Ornamentals. Within this hedgerow is also the invasive non-native species Butterfly Bush *Buddleja davidii*.

3.2.10 WL2-Treelines

There are small treelines, many of which are located around the GAA facilities and one small stretch in the south-west of the site which include the tree species Sycamore, a young Larch *Larix* spp, with False Oat-grass *Arrhenatherum elatius*, Perennial Ryegrass and Cocksfoot at base of trees.

These treelines also contain the non-native invasive species Cherry Laurel *Prunus laurocerasus*.

3.2.11 WS1 - Scrub

There is a section of Scrub along the north boundary of the site, which includes Grey Willow *Salix cinerea*, Bramble, Daisy Bush *Olearia* spp., and ground vegetation of Nettles, Thistle and Dock.

3.2.12 WS2 - Immature Woodland

There is a small patch of immature woodland in the north-west of the site which includes 17 planted Apple tree saplings, Meadow Buttercup, Yorkshire Fog and Thistle.

3.2.13 WS3 - Ornamental/non-native shrub

There is a small pocket of ornamental planting in the west of the site which includes Dogwood *Cornus sanguinea*, Holly *Ilex aquifolium* and a noticeable cover of Cheesewood *Pittosporum* spp. and Fuchsia *Fuchsia magellanica*.

3.2.14 Protected Flora

No floral species listed on the Flora Protection Order 2022 were recorded by the JBA Ecologist during the ecological walkover survey of the proposed site. The NBDC shows no record of any protected flora species being present within site or its immediate vicinity (NBDC, 2023). During the walkover survey, Irish Whitebeam *Sorbus hibernica* was recorded within the woodland in the east of the site. This species is currently listed as Vulnerable within the Irish Red List of Vascular Plants. Located throughout the site were many clusters of Cuckooflower *Cardamine pratensis*, this species is listed as being of Least Concern within the Irish Red List of Vascular Plants. The locations of Cuckooflower and of the Irish Whitebeam are shown below (Figure 3-6).

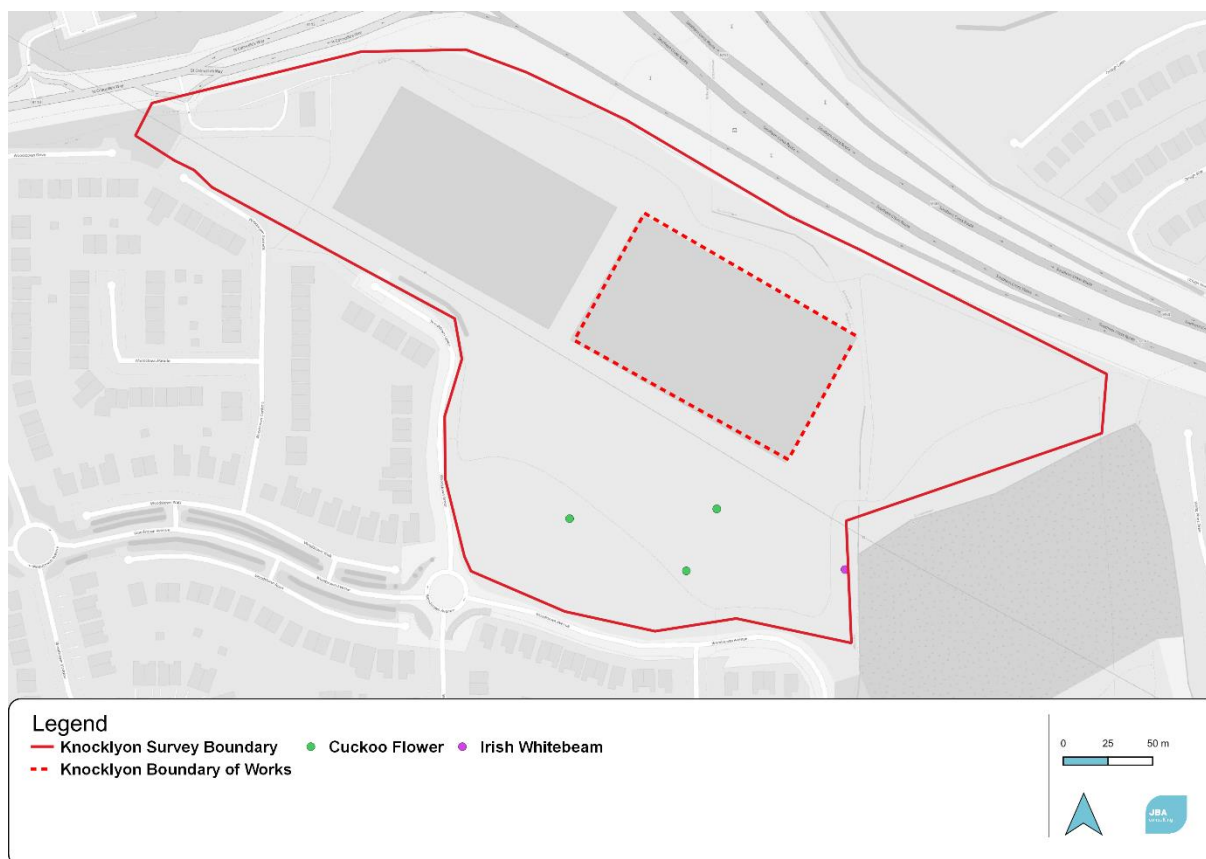

Figure 3-6: Location of Flora of Interest within the site (© OpenStreetMap contributors, 2023)

3.2.15 Protected Fauna

The JBA Ecologist recorded no bird species of conservation concern within the site boundary during the initial ecological walkover. Ten bird surveys were carried out in the period between November 2022 and March 2023. In summary, there was a frequent occurrence of Common and Black-headed Gull, however there were no other wintering birds of concern. A full list of the recorded species during these surveys are located below in Table 3-2.

Table 3-2: Bird species encountered during Bird Surveys

Day/Date	Time arrival/departure	of	Species
9th Nov2022	<ul style="list-style-type: none"> Present for full survey 		<ul style="list-style-type: none"> 37 Black-headed gulls
24th Nov 2022	<ul style="list-style-type: none"> Present at 9am Survey finished early due to bad weather 		<ul style="list-style-type: none"> 2 Herring Gull 43 Black-headed Gull Starling Jackdaw Rook Robin Wren
8th Dec 2022	<ul style="list-style-type: none"> Leaving at 9:45 Regular passing Others present 		<ul style="list-style-type: none"> Approx. 26 Black-headed gulls Woodpigeon Goldcrest and Blue Tit (trees near pylon)
16th Dec 2022	<ul style="list-style-type: none"> 9:30 flying over the site, didn't land Main Treeline 		<ul style="list-style-type: none"> 1 Black-backed Gull Blue Tits and Robins in main tree section

Day/Date	Time arrival/departure	of	Species
22nd Dec 2022	<ul style="list-style-type: none"> Present on arrival 9:10 -Arrival of birds Others present 		<ul style="list-style-type: none"> Between 32 and 57 mixed flock of Black head and Common gulls, and 1 first year Herring Gull Approximately 25 Common, 47 Black-headed gull House Sparrow, Robin, Dunnock (All along the verge of the field in the treeline)
6th Jan	<ul style="list-style-type: none"> 9:35 - 9:55 		<ul style="list-style-type: none"> Approx. 44 Gulls (Approx. 32 Black-headed, 12 Common)
20th Jan	<ul style="list-style-type: none"> 9:30 - 10:00 		<ul style="list-style-type: none"> 25 Black Headed Gull, 5 Common Gull
25th Jan	<ul style="list-style-type: none"> 10:20 - Arrival of birds 		<ul style="list-style-type: none"> 14 Black-headed, 6 Common Gull
8th Feb	<ul style="list-style-type: none"> 9am - Departure of birds 10:25 		<ul style="list-style-type: none"> 26 Gull species (Mixture of Common and Black headed) Arrival of 3 Common and 4 Black-headed
17th Feb	<ul style="list-style-type: none"> 9:15 9:45 Arrival of birds 10:10 Arrival of birds 		<ul style="list-style-type: none"> 2 Redwing (present within the tree border) 33 Gulls (28 Black-headed, 5 Common) 74 Gulls (66 Black-headed, 8 Common)
22nd Feb	<ul style="list-style-type: none"> 10:10 - Arrival of birds 		<ul style="list-style-type: none"> Mixture of Gulls (17 Black-headed, 7 Common)
28th Feb	<ul style="list-style-type: none"> Present on Arrival 10:00 Arrival of birds 10:15 Arrival of more birds 10:25 Departure of all present Gulls 10:55 Arrival of gulls 		<ul style="list-style-type: none"> 8 Black-headed Gulls (North of the field) 6 Common, 19 Black-headed Gulls 10 Common, 27 Black-headed Gulls 27 (17 Black-headed, 8 Common, 2 Herring)
15th March	<ul style="list-style-type: none"> 09:00 - 09:05 09:50 Arrival of more birds 		<ul style="list-style-type: none"> Approximately 55 Gulls, scared off by a dog before species could be identified 22 total Gulls, 14 Common and 8 Black Head
24th March	<i>No Birds present</i>		
30th March	<i>No Birds present</i>		

Desktop study findings of protected or red-listed species within a 5km radius of the site were collated from the National Biodiversity Centre Ireland (NBDC, 2023) and the Botanical Society of Britain and Ireland (BSBI, 2023), and are presented in Appendix D.

3.2.16 Invasive Non-native Species

Invasive non-native species recorded on-site during ecological walkovers of the site include Butterfly Bush and Sycamore; these species are stated to be Medium Impact species. Cherry Laurel was also encountered on the site, this species is a High Impact species, however none of these three species are listed on the third schedule of the EC (Birds and Natural Habitats) Regulations 2011 S.I. No. 477/2011.

3.3 Waterbodies within the Vicinity of the Proposed Site

The entirety of the proposed project is located within the Water Framework Directive (WFD) Liffey and Dublin Bay catchment, and within the Dodder_SC_010 sub-catchment (EPA, 2023).

There are no watercourses located within the area of the project, and the nearest watercourse is the Woodstown Stream which is approximately 65m to the south-east of the site. This watercourse is not assigned to any WFD river waterbodies, but it is culverted east, in the direction of the River Owenadoger (Owenadoher_010), which flows north and also joins the River Dodder. A culvert of the Orlagh River (Dodder_040) is located in close proximity to the site, which also flows in a northwards direction before reaching the River Dodder main body (Figure 3-7), and the River Dodder continues north before reaching the transitional river bodies of Dublin Bay. The WFD Status and Risk level of each of these WFD waterbodies are listed below in Table 3-3, and the connection between the site and Dublin Bay is shown Figure 3-7: Local river waterbodies (© OpenStreetMap contributors, 2023).

Table 3-3: WFD status and risk of local watercourses.

WFD Watercourse	WFD Status	WFD Risk	Approximate Distance from Site
Orlagh River (Dodder_040)	Moderate	At risk	0.2km (Culverted section)
Owenadoher River (Owenadoher_010)	Moderate	Review	1.7km
Liffey Estuary Lower	Moderate	At Risk	8.3km

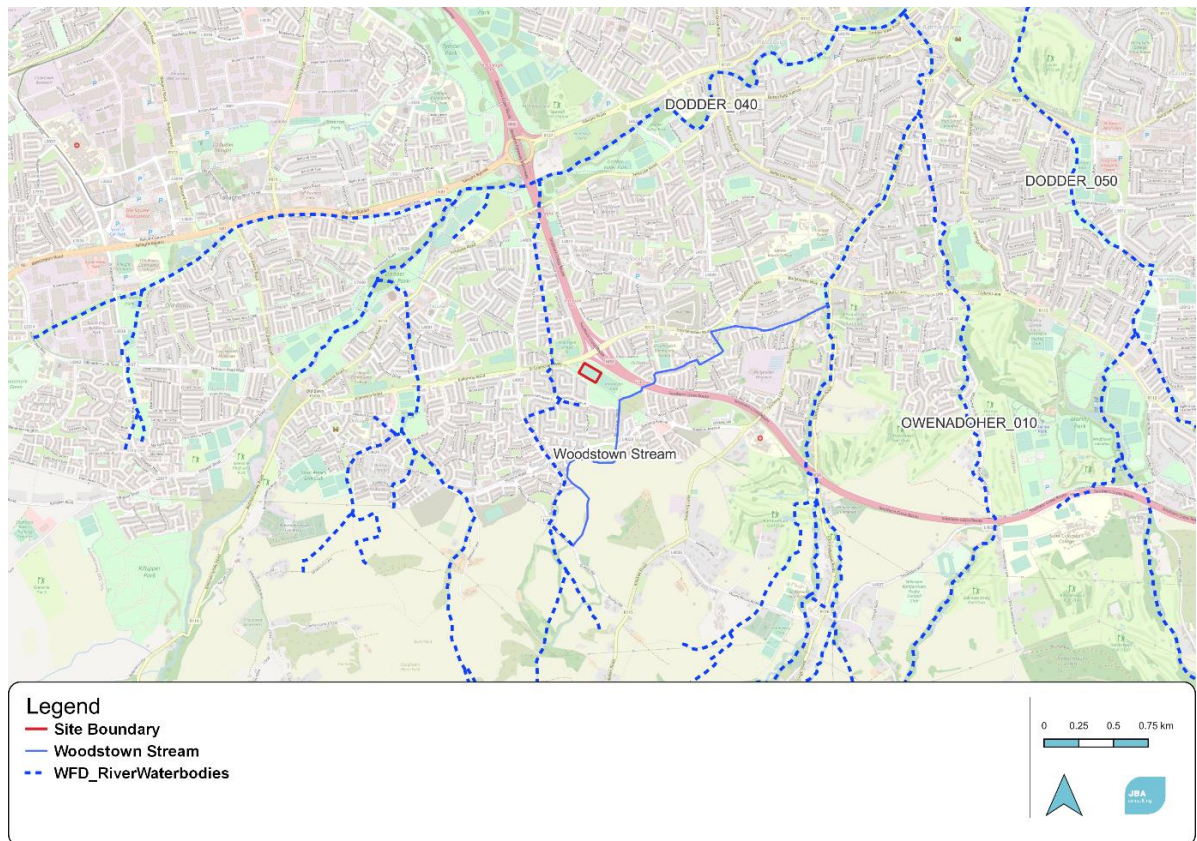

Figure 3-7: Local river waterbodies (© OpenStreetMap contributors, 2023)

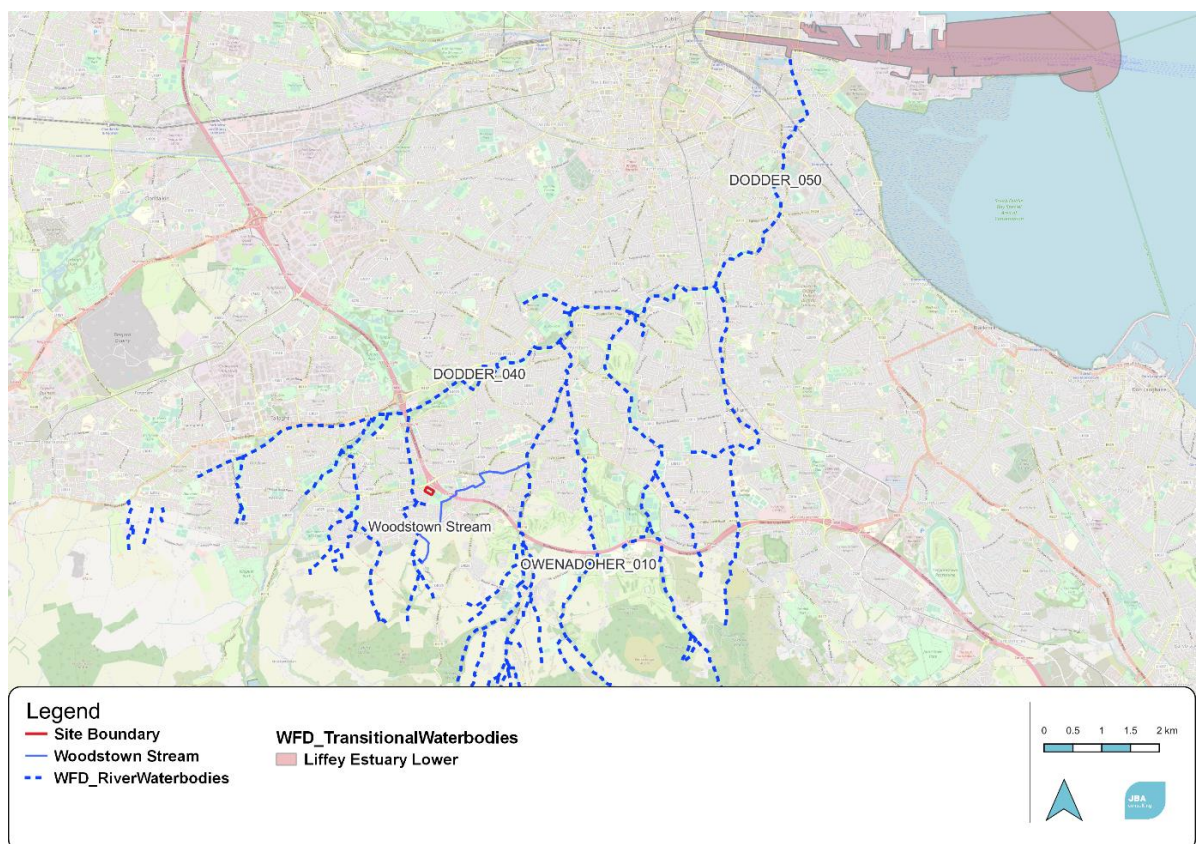

Figure 3-8: Riverrine connections from site to Dublin Bay (© OpenStreetMap contributors, 2023)

3.4 Groundwater

The entirety of the site is located within the Kilcullen groundwater body (shown in Figure 3-9). The Kilcullen groundwater body currently holds a 'Good' WFD status (2016-2021); and is considered to be 'At Risk'.

The underlying bedrock of the site is dominated by GranDark slate-schist, quartzite and coticule of the Butter Mountain formation, and the soil is derived of till derived chiefly from limestone. The permeability of the site's area is classified as Low with a very low recharge capacity of 7.5%. The groundwater in the area of the site has an overall Low vulnerability (Figure 3-10 ,overleaf).

The aquifer within the underlying bedrock is considered to be Locally important and is Moderately Productive only in Local Zones', meaning that the aquifer has a limited and relatively poor connection which has a low permeability that decreases further with depth, and has a poor storage and limited flow path. In the context of this site, this results in short, rapid discharging to local streams, springs and seeps, and any pollutants are likely to enter the Woodstown Stream surface waterbody, with the potential to enter the Orlagh River in the instance of leaky culverts.

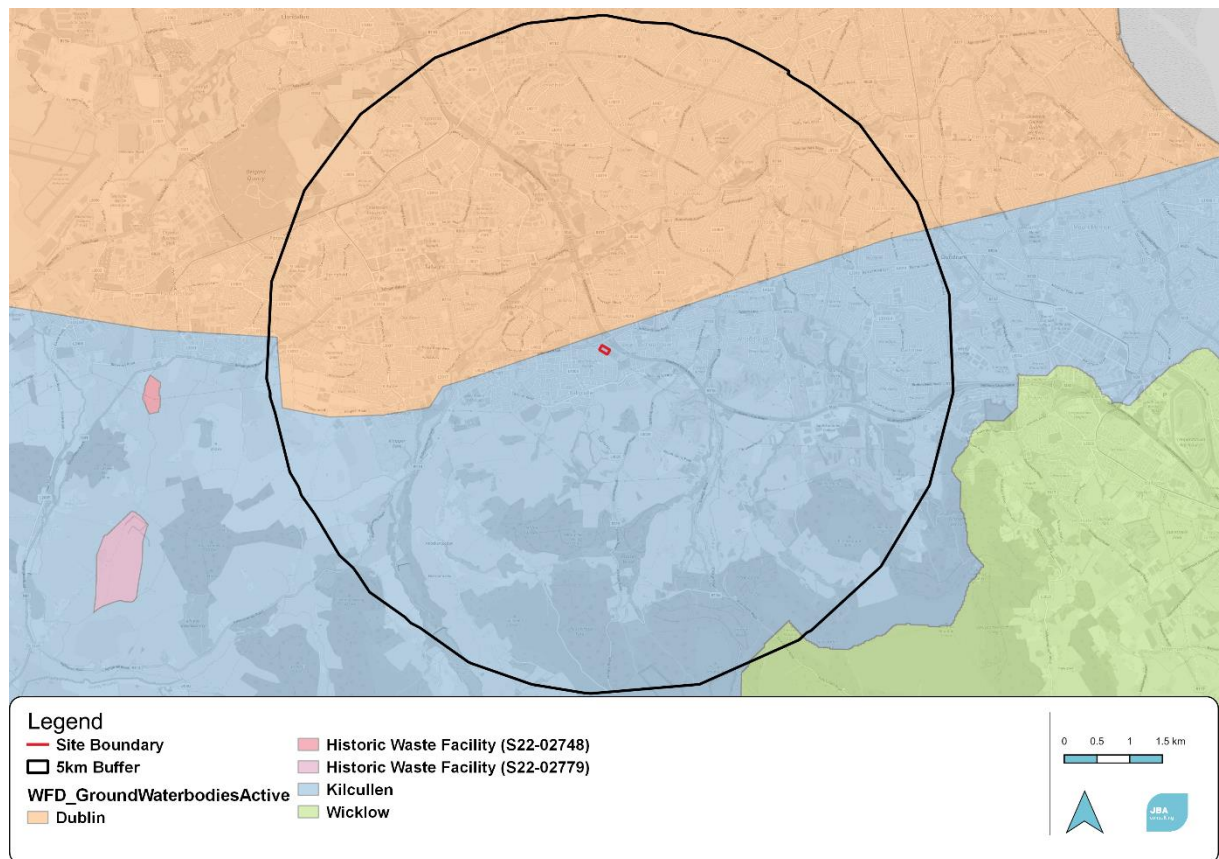

Figure 3-9: Groundwater bodies in the vicinity of site (© OpenStreetMap contributors, 2023)

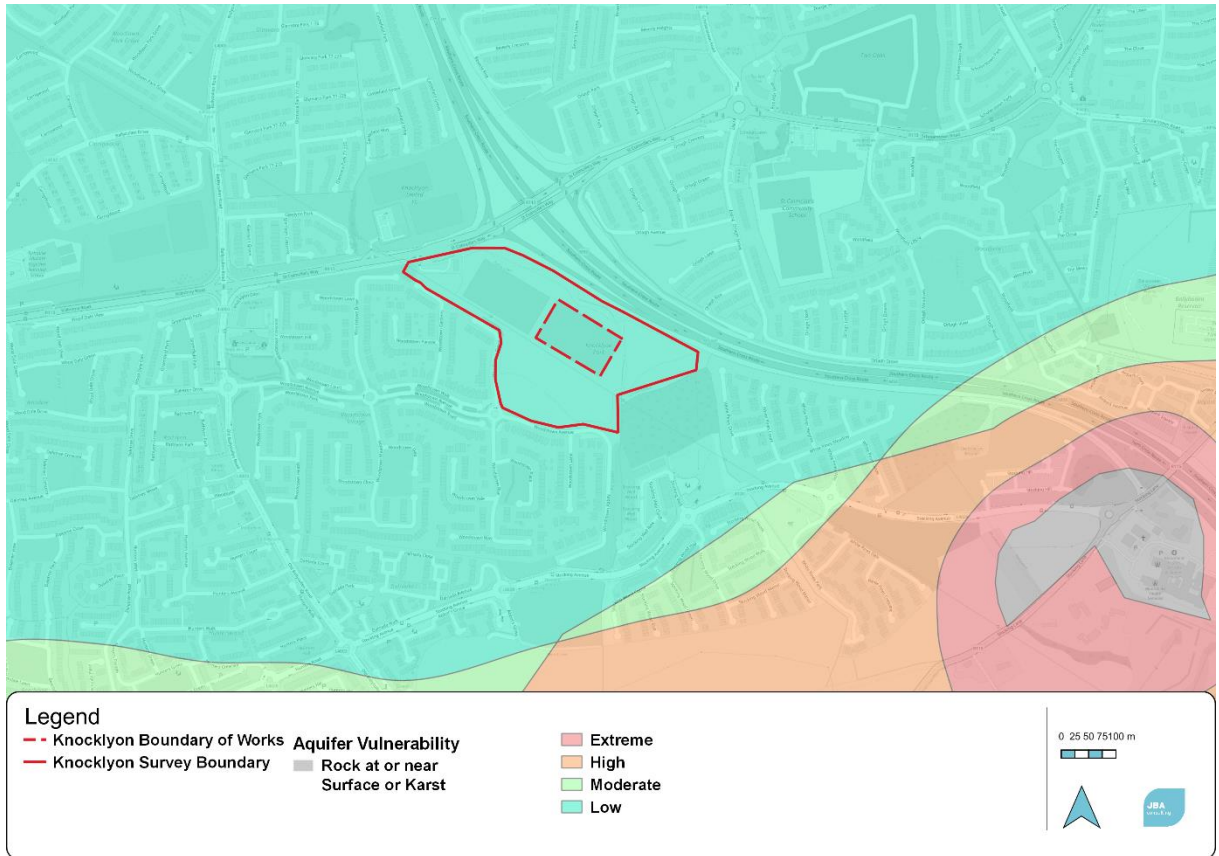

Figure 3-10: Aquifer vulnerability of the site (© OpenStreetMap contributors, 2023)

4 Natura 2000 Sites

The DEHLG (2009) guidance identifies that Screening for Appropriate Assessment of a plan or project should consider the following Natura 2000 sites:

- Any Natura 2000 sites within or adjacent to the plan or project area.
- Any Natura 2000 sites within the likely zone of impact of the plan or project. This is dependent on the nature and scale of the plan, with 15km generally recommended for plans, but potentially much less for projects.
- Any Natura 2000 sites that are more than 15km from the plan or project area, but may potentially be impacted upon, for example, through a hydrological connection.

As the scale of proposed works are considered of 'Project' status, Natura 2000 sites within a 5km range of the proposed development were examined, and within a 15km range for those with a hydrological connection on the basis that there were no source-pathway-receptors identified outside these ranges. The site was also considered for supporting habitat for SAC/SPA species (e.g. wintering birds) within (15km). The Natura 2000 sites within the range are listed in Table 4-1 below and their location are shown in Figure 4-1 (overleaf). Site descriptions, Qualifying Interests (QIs) and threats/pressures for the below Natura 2000 sites are provided in Table 4-2 (overleaf)

Table 4-1: Natura 2000 sites located within the Zone of Influence (ZoI) of the proposed development.

Natura 2000 site	Site Code	Approximate Distance from Site	Hydrological Distance from Site
Glenasmole Valley SAC	001209	3.5km	n/a
Wicklow Mountains SAC	002122	4.7km	n/a
Wicklow Mountains SPA	004040	4.4km	n/a
South Dublin Bay SAC	000210	9km	16.8km
South Dublin Bay and River Tolka SPA	004024	9km	15.8km
North Dublin Bay SAC	000206	13.8km	18.5km
North Bull Island SPA	004006	13.8km	18.5km

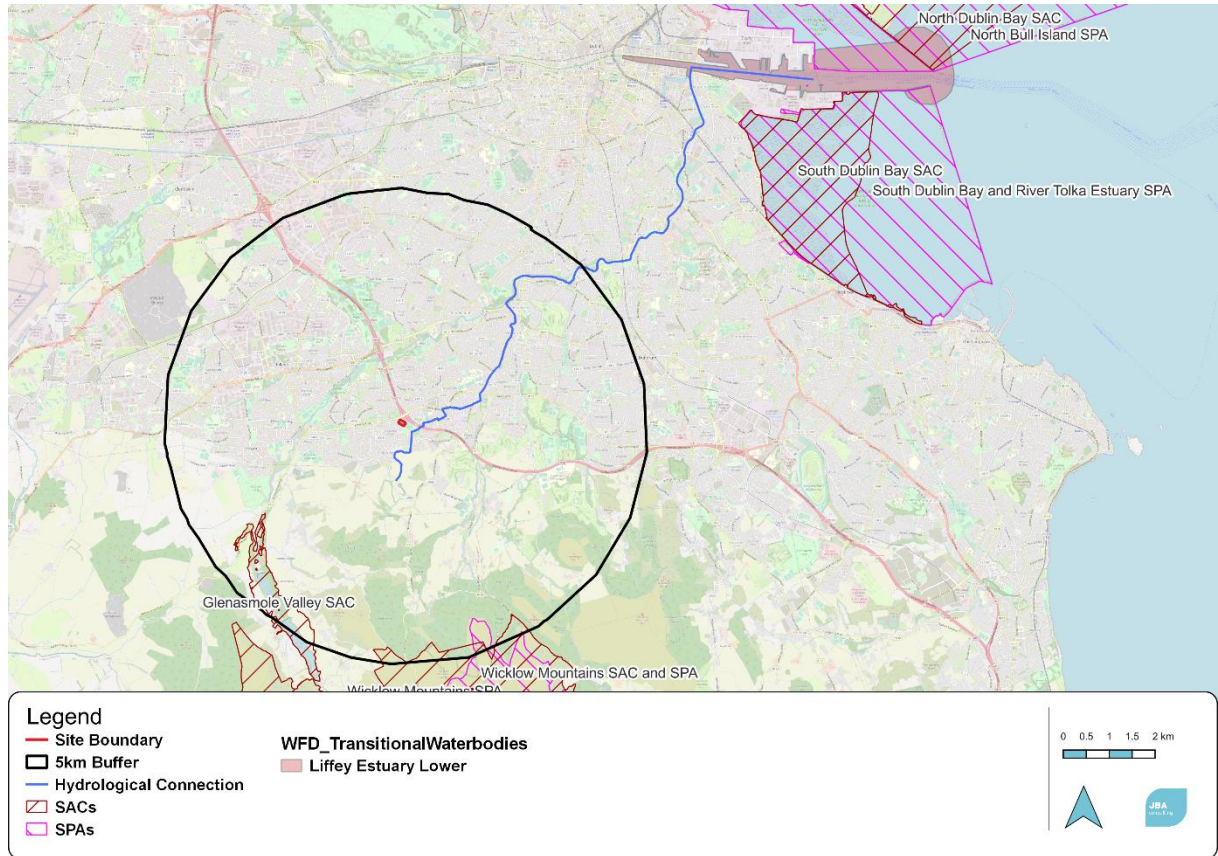

Figure 4-1: Natura 2000 sites within the 5km Zol and extended 15km hydrological connection
(© OpenStreetMap contributors, 2023)

As pollutants can be transported via watercourses and end up in Dublin Bay, the potential impact on the Dublin Bay Natura 2000 sites are assessed in detail in Section 6. Site descriptions, Qualifying Interests (QI) and threats/pressures for the above Natura 2000 sites are provided in Table 4-2

Table 4-2: Site briefs; Qualifying Interests; and project-relevant threats /pressures and their impacts and sources in relation to the Natura 2000 sites within the 5km ZoI (including hydrological connectivity extension).

Site Name	Brief	Qualifying Interests	Project-relevant Threats / Pressures: Impact (Source)
Glenasmole Valley SAC [001209]	Glenasmole valley is in south Co. Dublin approximately 5km from Tallaght. The River Dodder has been impounded within the valley to form two reservoirs for water provision to Dublin. The bedrock is non-calcareous with an overlay of deep drift deposits that line the valley's sides. These areas are covered by scrub and woodland, with herb-rich grassland on the less precipitous parts. Seepage through the deposits brings to the surface water rich in bases and induces patches of calcareous fens and petrifying springs. Locations between the two reservoirs include examples of calcareous fens and flush. Woodland occurs in patches around the site. The east side of the valley forms a woodland on the unstable calcareous slopes. Wet, semi-natural woodland is around the reservoirs. The lake shore vegetation is not well developed (NPWS, 2013a).	<ul style="list-style-type: none"> - Semi-natural dry grasslands and scrubland facies on calcareous substrates Festuco-Brometalia) (* important orchid sites) [6210] - <i>Molinia</i> meadows on calcareous, peaty or clayey-silt-laden soils (<i>Molinion caeruleae</i>) [6410] - Petrifying springs with tufa formation (Cratoneurion) [7220] (NPWS 2021) 	<ul style="list-style-type: none"> - Roads, paths and railroads - Discontinuous urbanisation - Invasive non-native species (EEA, 2018a)
Wicklow Mountains SAC [002122]	The Wicklow Mountains SAC is a complex upland region that extends through regions of Co. Wicklow and Dublin. Most of the site is over 300m, with the highest peak reaching 925m high. The mountain shows typical erosion patterns of multiple cycles, with the granite weathered characteristically into broad domes. Much of the west of the site consists of elevated moorland and peat. Surrounding schists have more diverse outlines forming peaks and rocky foothills with deep glens. The majority of the vegetation is a mosaic of wet and dry heaths, blanket bogs, upland grass, dense Bracken and small woodlands along the rivers. The rivers are predominantly acidic due to the underlying rock strata (NPWS 2017a).	<ul style="list-style-type: none"> - Oligotrophic waters containing very few minerals of sandy plains <i>Littorelletalia uniflorae</i> [3110] - Natural dystrophic lakes and ponds [3160] - Northern Atlantic wet heaths with <i>Erica tetralix</i> [4010] - European dry heaths [4030] - Alpine and Boreal heaths [4060] - Calaminarian grasslands of the <i>Violetalia calaminariae</i> [6130] - Species-rich <i>Nardus</i> grasslands, on siliceous substrates in mountain areas (and submountain areas, in Continental Europe) [6230] - Blanket bogs (* if active bog) [7130] - Siliceous scree of the montane to snow levels <i>Androsacetalia alpinae</i> and <i>Galeopsietalia ladani</i> [8110] - Calcareous rocky slopes with chasmophytic vegetation [8210] - Siliceous rocky slopes with chasmophytic vegetation [8220] - Old sessile oak woods with <i>Ilex</i> and <i>Blechnum</i> in the British Isles [91A0] - Otter <i>Lutra lutra</i> [1355] 	<ul style="list-style-type: none"> - Paths, tracks, cycling tracks - Urbanised areas, human habitation - Outdoor sports and leisure activities, recreational activities <p>(EEA, 2018b)</p>

Site Name	Brief	Qualifying Interests	Project-relevant Threats / Pressures: Impact (Source)
		(NPWS, 2017b)	
Wicklow Mountains SPA [004040]	The site is upland, comprising of a substantial part of the Wicklow Mountains, mainly confined to Co. Wicklow with a small area lying within Co. Dublin. Most of the site is higher than 300m, with the peak at Lugnaquilla being 925m high. The predominant substrate over the site is peat, with blanket bogs, heaths and upland grasses. Surveys of the Wicklow Mountains SPA have found that up to 9 pairs of Merlin breed within the site at any one year, using the open peatlands as excellent foraging habitats. The cliffs and crags are notable breeding locations for the Peregrine (NPWS, 2014a).	- Merlin <i>Falco columbarius</i> [A098] - Peregrine <i>Falco peregrinus</i> [A103] (NPWS, 2022)	- Paths, tracks, cycling tracks (EEA, 2020a)
South Dublin Bay SAC [000210]	The intertidal flats at their widest points are 3km with channels existing at largest with Cockle Lake. A small sandy beach occurs near to Dun Laoighre, with an almost entire artificial embankment. The sediments from the Tolka Estuary vary from thixotropic mud with a high organic content in the inner estuary to a well aerated and exposed sand system off of the Bull Wall. Insights show that many birds who winter in South Dublin Bay do not continue towards North Dublin Bay. (NPWS, 2015a)	- Mudflats and sandflats not covered by seawater at low tide [1140] - Annual vegetation of drift lines [1210] - <i>Salicornia</i> and other annuals colonising mud and sand [1310] - Embryonic shifting dunes [2110] (NPWS, 2013b)	- Roads, motorways - Urbanised areas, human habitation (EEA, 2020b)
South Dublin Bay and River Tolka SPA [004024]	This site covers a large part of the Dublin Bay, including the intertidal area of the River Liffey and Dun Laoghaire, along with the estuary of the River Tolka to the north of the River Liffey and Booterstown Marsh. The south of the bay has intertidal flats that at their widest extend for almost 3km. The site is important for wintering fowl, integral for the importance of the Dublin Bay complex (NPWS, 2015b).	- Light-bellied Brent Goose <i>Branta bernicla hrota</i> [A046] - Oystercatcher <i>Haematopus ostralegus</i> [A130] - Ringed Plover <i>Charadrius hiaticula</i> [A137] - Grey Plover <i>Pluvialis squatarola</i> [A141] - Knot <i>Calidris canutus</i> [A143] - Sanderling <i>Calidris alba</i> [A144] - Dunlin <i>Calidris alpina</i> [A149] - Bar-tailed Godwit <i>Limosa lapponica</i> [A157] - Redshank <i>Tringa totanus</i> [A162] - Black-headed Gull <i>Chroicocephalus ridibundus</i> [A179] - Roseate Tern <i>Sterna dougallii</i> [A192] - Common Tern <i>Sterna hirundo</i> [A193] - Arctic Tern <i>Sterna paradisaea</i> [A194] - Wetland and Waterbirds [A999] (NPWS, 2015c)	- Roads, motorways - Urbanised areas, human habitation (EEA, 2020c)
North Dublin Bay SAC	This SAC extends from the inner part of North Dublin Bay, and primarily focuses on North Bull Island. Dynamic dune systems and saltmarshes are found along this region. A variety of important and rare flora	- Mudflats and sandflats not covered by seawater at low tide [1140] - Annual vegetation of drift lines [1210]	- Urbanised areas, human habitation (EEA, 2020d).

Site Name	Brief	Qualifying Interests	Project-relevant Threats / Pressures: Impact (Source)
[000206]	habituate this SAC, including Lesser Centaury, Red Hemp-nettle, and Meadow Saxifrage. North Dublin Bay is also of international importance for waterfowl as it hosts Brent Goose, Knot, Bar-tailed Godwit, Oystercatcher, Ringed Plover, Sanderling, and Dunlin (NPWS, 2013c).	<ul style="list-style-type: none"> - <i>Salicornia</i> and other annuals colonising mud and sand [1310] - Atlantic salt meadows <i>Glauco-Puccinellietalia maritima</i> [1330] - Mediterranean salt meadows <i>Juncetalia maritimi</i> [1410] - Embryonic shifting dunes [2110] - Shifting dunes along the shoreline with <i>Ammophila arenaria</i> (white dunes) [2120] - Fixed coastal dunes with herbaceous vegetation (grey dunes) [2130] - Humid dune slacks [2190] - Petalwort <i>Petalophyllum ralfsii</i> [1395] (NPWS, 2013d) 	
North Bull Island SPA [004006]	This site covers all the inner part of north Dublin Bay, with the seaward boundary extending from Bull Wall lighthouse, to Howth Head. The spit in the north is relatively recent, almost 5km long, 1km wide and running parallel to the coast between Clontarf and Sutton. The saltmarsh extends the length of the landward side of the island, providing the main site for wintering bird roosting in Dublin Bay. The wintering waterfowl use two lagoons as their primary feeding grounds, these lagoons are divided by a causeway. (NPWS, 2014b)	<ul style="list-style-type: none"> - Light-bellied Brent Goose <i>Branta bernicla hrota</i> [A046] - Shelduck <i>Tadorna tadorna</i> [A048] - Teal <i>Anas crecca</i> [A052] - Pintail <i>Anas acuta</i> [A054] - Shoveler <i>Anas clypeata</i> [A056] - Oystercatcher <i>Haematopus ostralegus</i> [A130] - Golden Plover <i>Pluvialis apricaria</i> [A140] - Grey Plover <i>Pluvialis squatarola</i> [A141] - Knot <i>Calidris canutus</i> [A143] - Sanderling <i>Calidris alba</i> [A144] - Dunlin <i>Calidris alpina</i> [A149] - Black-tailed Godwit <i>Limosa limosa</i> [A156] - Bar-tailed Godwit <i>Limosa lapponica</i> [A157] - Curlew <i>Numenius arquata</i> [A160] - Redshank <i>Tringa totanus</i> [A162] - Turnstone <i>Arenaria interpres</i> [A169] - Black-headed Gull <i>Chroicocephalus ridibundus</i> [A179] - Wetland and Waterbirds [A999] (NPWS, 2015d) 	<ul style="list-style-type: none"> - Continuous urbanisation - Other patterns of habitation (EEA, 2020e)

* = priority Annex I habitat

= indirect threat via the increase in the local populace and recreational activities as a result of the development.

5 Other Relevant Plans and Projects

5.1 Cumulative Effects

As part of the Screening for an Appropriate Assessment, in addition to the proposed works, other relevant projects and plans in the region that may induce cumulative impacts must also be considered at this stage.

5.2 Plans

The following projects or plans were identified as potential sources of cumulative impacts:

- South Dublin County Development Plan 2022-2028
- Greater Dublin Drainage Strategy
- Third Cycle River Basin Management Plan for Ireland 2022-2027
- Planning Applications (retrieved from Data.gov.ie - Planning Application Sites, April 2023)

5.2.1 South Dublin County Development Plan 2022-2028

The proposed scheme's development is in line with the South Dublin County Development Plan 2022-2028. It is an objective of the Plan to ensure that all development within the County conforms to key design principles which includes the promotion of sustainable energy and environmental services. These goals include the requirement that the planning system will 'be responsive to our national environmental challenges and ensure that development occurs within environmental limits, having regard to the requirements of all relevant environmental legislation and the sustainable management of our natural capital.'

The Plan also aims to protect and enhance surface water quality, to support, improve and protect Natura 2000 sites, and to develop an integrated Green Infrastructure network to enhance biodiversity, provide accessible parks, open spaces and recreational facilities (SDCC, 2022a). The plan also states that work will be in conjunction with Irish Water to protect existing water and drainage infrastructure, to promote investments aiming to support environmental protection and facilitate the sustainable growth of the county.

A Screening for Appropriate Assessment was carried out on the plan, which was concluded that an Appropriate Assessment was necessary for this project. The associated Natura Impact Report concluded that there are no likely significant direct, indirect or secondary impacts of the project on any Natura 2000 sites (SDCC, 2022b), **therefore the SDCC Development Plan is not anticipated to contribute to cumulative or in-combination impacts.**

5.2.2 Greater Dublin Drainage Strategy

The Greater Dublin Drainage Strategy sets out the strategic planning for the development of wastewater treatment in the Greater Dublin Area in relation to the Ringsend Waste Water Treatment Plant (WWTP) Upgrade, Greater Dublin Drainage Project and associated wastewater network drainage projects (Irish Water, 2018). The proposed developed connects with the Local Authority sewer system which is included in this strategy. The Ringsend WWTP Upgrade includes plans to expand the WWTP to its ultimate capacity, together with associated network upgrades required. The Greater Dublin Drainage Project is planned to relieve both the Ringsend WWTP and network loading by construction of a new WWTP at Clonshaugh, an orbital sewer and provision of an outfall pipe discharging 1km north east of Ireland's Eye. The Ringsend WWTP upgrade is in progress and carried out in stages, with an increased capacity of 400,000 PE by the first half of 2021 and the ultimate capacity of 2.4 million PE to be in operation by 2025 (Irish Water, 2018). The Greater Dublin Drainage Project is strategically important to the Dublin Region in that it will provide capacity for residential and commercial growth (Irish Water, 2018).

The Greater Dublin Drainage Strategy is not anticipated to contribute to cumulative or in-combination effects.

5.2.3 Third Cycle River Basin Management Plan for Ireland 2022-2027 (DoHPLG, 2022)

The first cycle of River Basin Management Plans included the Eastern River Basin District - River Basin Management Plan (ERBDMP) 2009 – 2015 (WFD (2010)). The plans summarised the waterbodies that may not meet the environmental objectives of the WFD by 2015 and identified which pressures are contributing to the environmental objectives not being achieved. The plans described the classification results and identified measures that can be introduced in order to safeguard waters and meet the environmental objectives of the WFD.

- Prevent deterioration of water body status.
- Restore good status to water bodies.
- Achieve protected areas objectives.
- Reduce chemical pollution of water bodies

The 2nd cycle River Basin Management Plan (RBMP) for Ireland 2018-2021 sets out the actions that Ireland will take to improve water quality and achieve ‘good’ ecological status in water bodies (rivers, lakes, estuaries and coastal waters) by 2021 (DoHPLG, 2018a). Changes from previous River Basin Management Plans is that all River Basin Districts are merged as one national River Basin District. The Plan provides a more coordinated framework for improving the quality of our waters — to protect public health, the environment, water amenities and to sustain water-intensive industries, including agri-food and tourism, particularly in rural Ireland.

The 3rd and current cycle aims to build on the initiatives of the second cycle, particularly the governance and implementation structures, and to improve the establishment of Irish Water, An Forum Uisce, the Local Authority Waters Programme and the Agricultural Sustainability Support and Advisory Programme.

The third cycle draft Catchment Report for Liffey and Dublin Bay Catchment (Catchment Science & Management Unit, 2021) identified that between Cycles 2 and 3 there has been an overall small improvement in the catchment's status. The overall change in quality between Cycles 2 and 3 include 2 waterbodies that have achieved High Status, which is an increase of one, 56 which achieve Good Status has been increased by four, 23 achieving a Moderate Status which is a decrease in four waterbodies, and 24 achieving a Poor Status an increase of 1 between cycles. There are no Bad Status waterbodies as of Cycle 3, which is a decrease of one from Cycle 2. The main significant pressures are aquaculture, anthropogenic, atmospheric, historically polluted sites and waste pressures followed by agriculture, urban run-off and forestry.

The Third Cycle River Basin Management Plan for Ireland 2022-2027 is not anticipated to contribute to cumulative or in-combination effects.

5.3 Other Projects

There are no other projects dating back three years, which are not retention applications, home extensions and/or internal alterations that have the potential overlapping construction and short-term residual impact phases with the proposed development.

5.4 Summary

The County and Local Development Plan; Greater Dublin Drainage Strategy and River Basin Management Plan are considered in combination with the currently proposed project in the Screening Assessment section below.

6 Screening Assessment

6.1 Introduction

This screening exercise will focus on assessing the likely adverse effects of the project on the Natura 2000 sites identified in Section 4 above.

This section identifies the potential impacts which may arise as result of the proposed project. It then goes on to identify how these impacts could potentially impact on Natura 2000 sites listed in Table 4-1. The significance of potential impacts is also assessed, with any potential in-combination effects also identified.

The Natura 2000 sites to be assessed are:

- Glenasmole Valley SAC [001209]
- Wicklow Mountains SAC [002122]
- Wicklow Mountains SPA [004040]
- South Dublin Bay SAC [000210]
- South Dublin Bay and River Tolka SPA [004024]
- North Dublin Bay SAC [000206]
- North Bull Island SPA [004006]

This section identifies the potential impacts which may arise as result of the proposed project. It then goes on to identify how these impacts could potentially impact on Natura 2000 sites listed in Table 4-1. The significance of potential impacts is also assessed, with any potential in-combination effects also identified.

6.2 Assessment Criteria

6.2.1 Description of the individual elements of the project (either alone or in combination with other plans or projects) likely to give rise to impacts on the Natura 2000 sites

Potential adverse impacts that could cause a significant effect on the qualifying interests of the Natura 2000 sites, during the construction and operational phases of the project, will impact on the sites via surface water pathways, groundwater pathways and land and air pathways. Surface water pathways can impact on surface water quality and surface water dependent habitat quality. Groundwater pathways can impact on groundwater quality and quality of groundwater dependent habitats. Land and air pathways can impact by release or discharges of sediment or chemicals to surface or groundwater.

The proposed project is not anticipated to impact on the qualifying interests of any the Natura 2000 sites. The rationale for excluding impacts via the main pathways is given in more detail in the following sub-section.

6.2.2 Surface Water Pathways

Potential pollutants will be used on-site, which will include oil and petrol/diesel related to machinery, dust and soil spill related to excavations, and materials from the proposed Synthetic 3G Pitch. The proposed project is located within the WFD Liffey and Dublin Bay catchment, and the Dodder_SC_010 sub-catchment. (Figure 6-1, overleaf). The site does not share its sub-catchment with the Natura 2000 sites North Dublin Bay SAC and North Bull Island SPA, however they are connected to the site through local watercourses and will continue to be assessed further.

The site shares the sub-catchment with Glenasmole Valley SAC and the Wicklow Mountain Natura 2000 sites, however these do not lie downstream of the project site, and therefore these Natura 2000 sites are not considered any further.

The local Woodstown Stream is approximately 65m south-east from the site of the proposed artificial pitch. Between the pitch and the stream, is an elevated area of amenity and meadow grassland, along with various woodland areas which would act as buffers between the site development and the stream. The stream is culverted to the east, under the M50, before joining with the River Owenadoher and there is a culverted section of the Orlagh River nearby, west of the site. Both of these rivers flow north and connect with the River Dodder at two different locations, before the River Dodder continues to flow

north-east and then north before entering the Liffey Estuary Lower Transitional waterbody, and into the Dublin Bay Natura 2000 sites. Due to the low likelihood of pollutants entering the local waterbody, and the short temporary scale of the construction works, and the long distance between the site and the Natura 2000 sites impacts on the Dublin Bay Natura 2000 sites are not anticipated.

Therefore, due to the lack of direct connection and the presence of a vegetation buffer to the nearest watercourse, the distance from the local watercourse to Dublin Bay, and the temporary nature of construction works, adverse impacts via surface water pollution events during the construction phase are not anticipated for the Natura 2000 sites within the Zol.

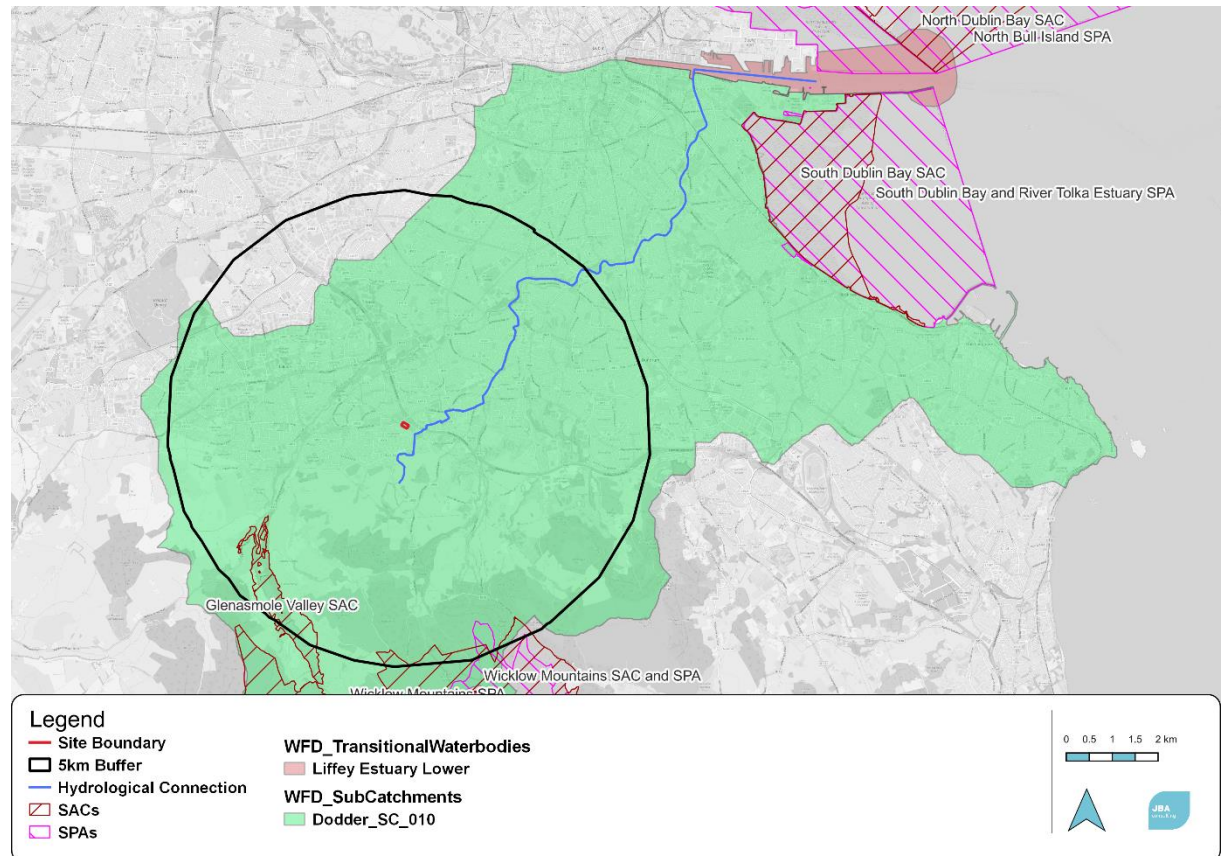

Figure 6-1: WFD sub-catchment of the surrounding area, and hydrological connection of the project site (© OpenStreetMap contributors, 2023)

Operational Phase

During the operation of the pitch, there is potential for gradual loss of synthetic pellets from the pitch through wind, rainwater runoff, and transmission through athlete's clothes with the potential for pellets to enter the Woodstown Stream and then to enter Dublin Bay. However there are standard design controls in place at the facility to prevent loss of pellets, as outlined in works description. Even if there is some loss of pellets via clothing and footwear, the distance and vegetation buffer between the proposed pitch and the watercourse will prevent significant amounts of synthetic pellets entering the Woodstown stream and reaching any Natura 2000 sites in Dublin Bay, thus ensuring that no impacts to the Natura 2000 sites are anticipated.

Therefore, adverse impacts via surface water pollution events during the operational phase are not anticipated for any Natura 2000 sites; and their respective QIs.

6.2.3 Groundwater

The whole site is encompassed by the Kilcullen groundwater body (Figure 6-2). The North Dublin Natura 2000 sites are not located within this waterbody and therefore are not considered any further.

The Glenasmole Valley SAC, Wicklow Mountains Natura 2000 sites, and South Dublin Bay Natura 2000 sites are all within the same groundwater body as the project. Given the Low vulnerability, Low recharge

rate, and Low permeability of the groundwater body, pollutants are unlikely to contaminate the groundwater body.

Given the poor transmission qualities of the local aquifer, any pollutants that do enter the groundwater, are unlikely to reach any Natura 2000 sites through the groundwater pathway, are unlikely to be retained for long and are likely to be discharged into a local waterbody; i.e. a ground-to-surface water pathway is created due to this discharge. Even if polluted groundwater did reach the Woodstown Stream it is likely to be in very small amounts due to the nature of the development The culverting of the Orlagh River also restricts discharge of groundwater to this water body. As outlined in Section 6.2.2, there are no anticipated impacts related to surface water pollutants due to the long distance between the nearest water course and the Natura 2000 sites in Dublin Bay.

Given the small-scale operations and the limited number of pollutants from the project that will reach enter the groundwater body, and the low retention rate of pollutants within the groundwater body, **adverse impacts via groundwater pollution events during the construction and operational are not anticipated for the Natura 2000 sites within the Zol.**

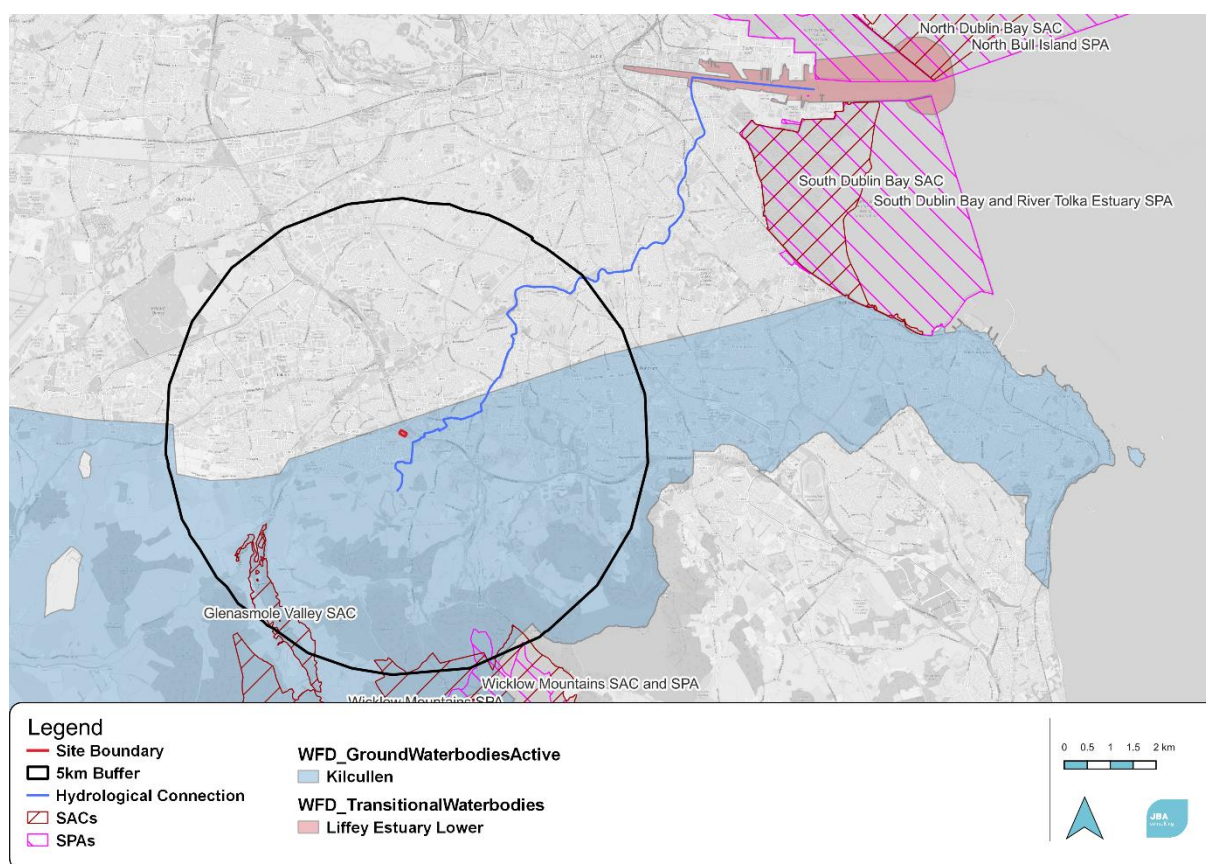

Figure 6-2: Groundwater bodies around the proposed site in respect to Natura 2000 sites (© OpenStreetMap contributors, 2023)

6.2.4 Land and Air

The loss or degradation of supporting habitats outside the identified Natura 2000 sites via land- and air-based impacts could have potential adverse impacts on a number of the QIs associated with these Natura 2000 sites. Land and air pathways are assessed separately below.

Land (physical on-site and noise disturbance)

The construction works will temporarily increase the noise level and disturbance locally. Direct physical impacts and indirect impacts, such as visual and noise impacts, do not have the potential to physically disturb habitats as well as the floral and faunal species within them due to the distance from the proposed site to any of the Natura 2000 sites within the Zol.

As the proposed development will not result in any physical land-take from the Natura 2000 sites within the Zol, therefore, physical land-take impacts are not anticipated for the any of the Natura 2000 sites, and their respective QIs.

While bird species that are qualifying interest of some coastal Natura 2000 sites, such as Light-bellied Brent Goose *Branta bernicla*, are known to frequent large parks in Dublin to graze on short turf grass during the latter half of the winter months (Enviroguide Consulting, 2019), during the wintering bird surveys, no Brent Geese or any other bird of qualifying interest for any Natura 2000 site was recorded on site. Additionally, there is no NBDC record of Brent Goose occurring within 5km of the site, and it can be concluded that works on this site do not pose a threat of disturbance to any QI bird species.

Therefore, disturbance-based impacts are not anticipated during the construction and operational phases for the any of the Natura 2000 sites, and their respective QIs.

Air Pollution

Excavations at the site will be shallow, and this will disturb the present top and sub soil, emissions may arise from working machinery, and synthetic pellets may be blown away during construction. Dust release and vehicle emissions can travel considerable distances and could potentially impact the QIs of Natura 2000 sites. The recommended buffer for dust and air pollution is 2km as a baseline (NRA, 2011), however, the distance and direction of travel is also influenced by wind speed and direction.

The prevailing wind in the area is west-south-west (based on measurements carried out between 2021-2022 from Churchtown/Dublin (Windfinder.com, 2023)). Any dust that is generated on-site will most likely be transported in an east-north-east direction, and towards the South Dublin Bay Natura 2000 sites within the Zol. However, the urban setting of the proposed development also provides barriers, such as buildings, which will prevent further dispersal of particles.

Access to the site will be on pre-existing roads, and there will be an increase in local traffic attending the site during construction, resulting in an increase in NOx emissions, however vehicular emissions and dust emissions are not anticipated to significantly impact the QIs of the any Natura 2000 sites due to the relatively small size and temporary nature of proposed works.

Therefore, due to the distance, the relatively small size and temporary nature of proposed works potential adverse impacts via the air pathway are not anticipated during the construction phase for the Natura 2000 sites and their respective QIs.

Air pollution-based impacts from dust / emissions are not anticipated during the operational phase of the proposed development.

6.2.5 Cumulative Impact

In assessing the plans outlined in Section 5, the respective AA screenings were consulted to assess the potential of any cumulative impacts due to their proximity of the site. All of these plans were concluded to not pose any threat to Natura 2000 sites.

As the proposed project is not anticipated to have any significant impact on QIs or conservation objectives on any Natura 2000 site and based on the screening statements of the above plans and planning applications, there is no potential for other plans or projects to act in combination with it to result in likely significant impacts on Natura 2000 sites.

6.2.6 Summary

Due to the location of the proposed site, the temporary nature of the works and its distance to the Natura 2000 sites within the Zol, the proposed project is not anticipated to have a significant impact via surface water, groundwater, groundwater to surface water, and land and air pathways to any Natura 2000 site.

6.2.7 Description of likely direct, indirect or secondary impacts of the project (either alone or in combination with other plans or projects) on the Natura 2000 sites

Project Elements	Comment
Size and scale	<p>The project consists of A new 3G synthetic pitch to be primarily used for full sized soccer, GAA and Rugby with line markings for cross-field play as an option in the future. The pitch is to be compliant with performance for all sports. The facility would be completed with an access route, spectator area, fencing and netting, floodlighting and equipment. The new 3G synthetic pitch is proposed to include a minimum turf/pile length of 60mm complete with a robust shock pad with sand and rubber infill materials to ensure that in terms of safety and performance the product is certified for all proposed sports to be played on it.</p> <p>The scope of the works include:</p> <ul style="list-style-type: none"> • Apply fertiliser to proposed grass development area. • Excavate and remove all topsoil's over the grassed development area (thickness TBC conjectured at 250mm) • Earthworks cut and fill to new formation • Apply separator membrane and geogrid system on formation. • Installation of parallel drainage network completion with carrier drainage and cut off drain as required, to form a new outfall or attenuation tank as necessary. • Install new internal perimeter kerbing. - Installation of crushed stone sub-base including any blinding layer 300 mm. • Installation of engineered base layer (porous 40mm minimum) • Installation of new 5m high perimeter fencing with an increased 10m minimum ball stop nets behind both GAA goals. • Installation of new 8-column floodlighting system • Installation of new spectator area including new 1.2m spectator guard rail. • Installation of new prefabricated shockpad. • New 60mm 3G synthetic turf, complete with infill and line markings cut in/in laid. • Landscaping and reinstatement of surrounding area
Land-take	There will be no direct land take from any of Natura 2000 sites.
Distance from Natura 2000 site or key features of the site	<ul style="list-style-type: none"> • Glenasmole Valley SAC • 3.5km • Wicklow Mountains SAC • 4.7km • Wicklow Mountains SPA • 4.4km • South Dublin Bay SAC • 9km • South Dublin Bay and River Tolka SPA • 9km • North Dublin Bay SAC • 13.8km • North Bull Island SPA • 13.8km
Resource requirements (water abstraction etc.)	There will be no water abstraction requirement.
Emissions (disposal to land, water or air)	<p>Construction Phase:</p> <p>Water</p> <p>The proposed site lacks any direct hydrological links with the Natura 2000 sites within the ZoI. There is a notable vegetation buffer between the site of works and the local watercourse, and any pollutants that enter the watercourse are likely to settle out of</p>

Project Elements	Comment
	<p>solution before reaching Dublin Bay. Therefore, surface water-based emissions to the local freshwater systems flowing into the Natura 2000 sites is not anticipated.</p> <p>Air Excavations at the site will produce loose top and sub soil, emissions may arise from working machinery, and pollutants including synthetic pellet material and dust may be produced during construction. The proposed site has a west-south-west prevailing wind year-round, therefore, any dust and emissions generated on-site will most likely be transported in the direction of the Dublin Bay Natura 2000 sites. Due to the distance between the project site and these Natura 2000 sites, along with the obstruction of the wind pathway by the urban setting of the project, impacts through air-based pollutants are not anticipated.</p> <p>Operation phase:</p> <p>Water The operational phase of the project could lead to gradual transmission of synthetic pellets into the surrounding environment. Given the vegetation buffer between the pitch and Woodstown Stream and the downstream distance to the Natura 2000 sites, there will be no permanent impacts on any Natura 2000 site in Dublin Bay.</p> <p>Air Impacts through air-based pollutants during the operation phase are not anticipated.</p>
Excavation requirements	Excavations will include: Removal of topsoil to a conjectured thickness at 250mm and excavations of between 2m to 7m for the soakaway
Transportation requirements	<p>Temporary Impacts: Levels of traffic to the site during the construction phase will increase traffic to the area but will be temporary in nature. All access to the site will be on pre-existing roads and transportation requirements will not affect Natura sites.</p> <p>Permanent Impacts: Given the size, scale and location of the proposed project, transportation requirements will not affect Natura 2000 sites.</p>
Duration of construction, operation, decommissioning etc.	Works are anticipated to take six months
Other	None

6.2.8 Description of likely changes to the Natura 2000 sites

Potential Impact	Comments
Reduction of habitat area	There will be no reduction in habitat area for any of the Natura 2000 sites.
Disturbance to key species	<p>Temporary Impacts: The construction works will temporarily increase the noise level and disturbance locally. However, no significant impacts are</p>

Potential Impact	Comments
	<p>anticipated to key species given scale and temporary nature of the construction phase and distance from the Natura 2000 sites.</p> <p>Permanent Impacts: No disturbance to key species is anticipated during operation of the project.</p>
Habitat or species fragmentation	There will be no temporary or permanent habitat or species fragmentation within any of the Natura 2000 sites.
Reduction in species density	There will be no temporary or permanent reduction in species density within any of the Natura 2000 sites, or any QIs of these sites.
Changes in key indicators of conservation value (water quality etc.)	There will be no temporary or permanent changes in key indicators of conservation value (surface water, groundwater and air quality).
Climate change	N/A
Interference with the key relationships that define the structure of the site	There will be no interference with the key relationships that define the structure of the sites.
Interference with key relationships that define the function of the site	There will be no interference with the key relationships that define the function of the sites.
Loss (Estimated percentage of lost area of habitat)	No Natura 2000 sites will experience a direct loss in habitat area.
Fragmentation	Fragmentation of habitat and/or species is not anticipated.
Disruption & disturbance	Disruption and/ or disturbance is not anticipated.
Change to key elements of the site (e.g. water quality etc.)	Potential temporary changes to key elements (i.e. water quality) of the Natura sites are not anticipated.

6.2.9 Describe from the above those elements of the project or plan, or combination of elements, where the above impacts are likely to be significant or where the scale or magnitude of impacts is unknown

Based upon best scientific judgement, significant impacts are not expected from the elements mentioned above, and there are no elements where the scale or magnitude of impacts is unknown.

6.3 Concluding Statement

In carrying out this AA screening, mitigation measures have not been taken into account. Standard best practice construction measures which could have the effect of mitigating any effects on any European Sites have similarly not been taken into account.

On the basis of the screening exercise carried out above, it can be concluded that the possibility of any significant adverse impacts on the Natura 2000 sites within the ZOI, whether arising from the project itself or in combination with other plans and projects, can be excluded beyond a reasonable scientific doubt on the basis of the best scientific knowledge available.

Appendices

A Site Layout Plan

Electrical supply for floodlighting to be taken from existing clubhouse

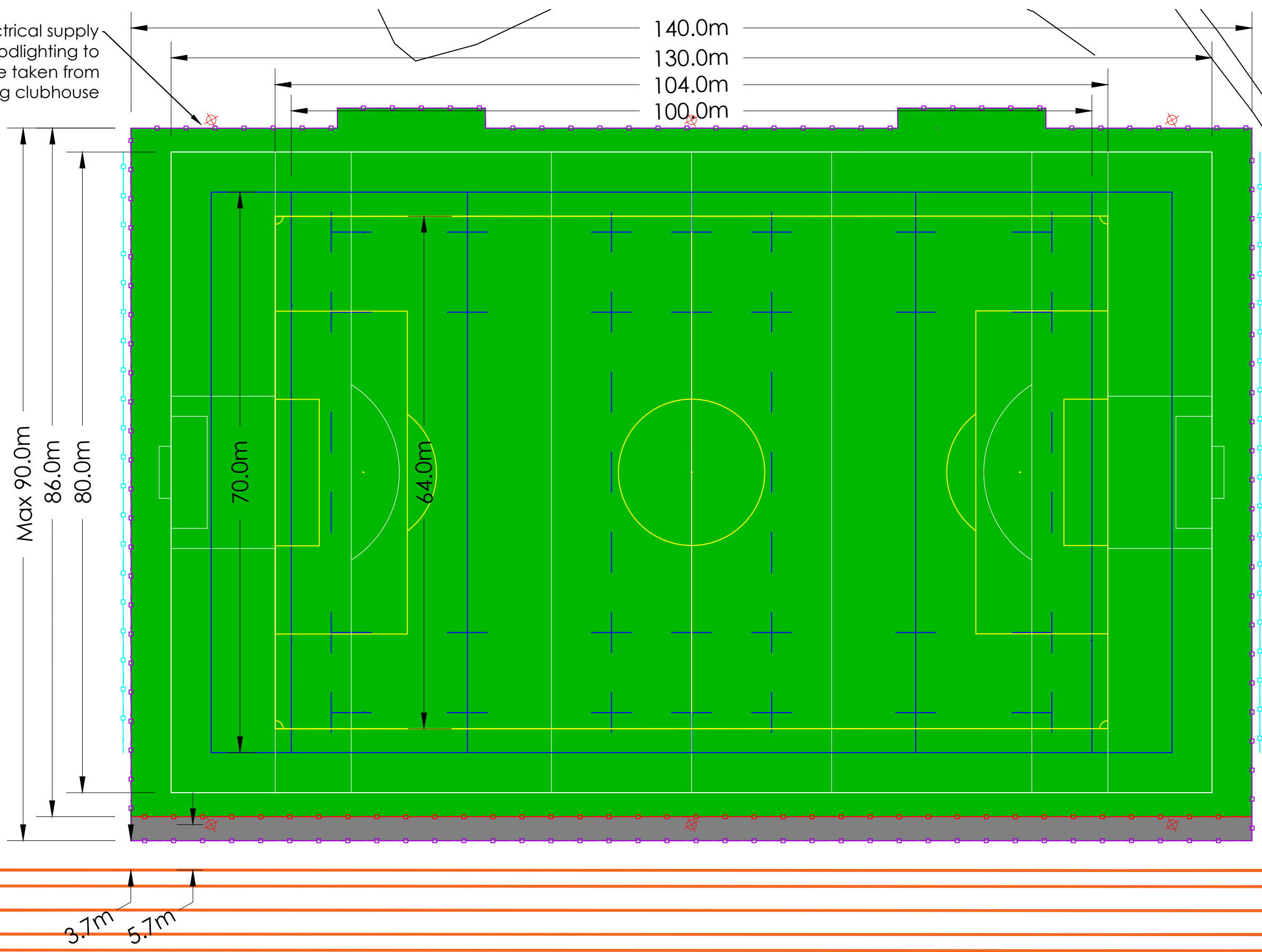

NOTES
 It is the contractor's responsibility to check design levels and sizes for compliance. Any discrepancies or errors to be identified to the design team.

Line markings to be finalized at detailed design stage.

Synthetic Area	
Length	- 140.0m
Width	- 81.0m
Recess area x 2	- 2.5m x 18.5m
Total	- 11,433m²

- KEY**
- Perimeter Fencing
 - Spectator Fencing
 - Ballstop Netting
 - 60mm 3G Synthetic Turf
 - Floodlighting Column
 - ESB Power Line

Max 90.0m
 86.0m
 80.0m

70.0m

64.0m

3.7m
 5.7m

REVISION	DETAILS	BY	DATE	CHECKED



**KNOCKLYON PARK
 GENERAL ARRANGEMENT
 CONSTRUCTION OF A NEW ARTIFICIAL PITCH**



Date: 04/2023 Scale: 1:500 @ A3	Job. No. 3096	Drawn by: GS Checked by: CH
------------------------------------	---------------	--------------------------------

01 | GENERAL ARRANGEMENT
 SCALE: 1:500

NOTES
It is the contractors responsibility to check design levels and sizes for compliance. Any discrepancies or errors to be identified to the design team.

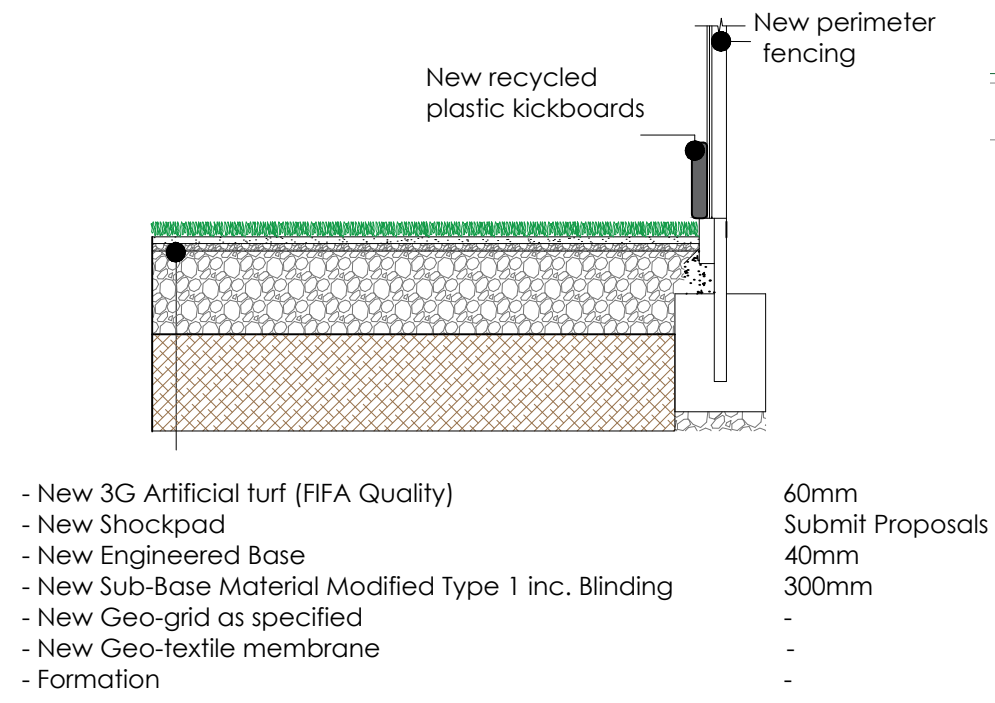

01 STANDARD PITCH KEY IN SECTION
SCALE: 1:25

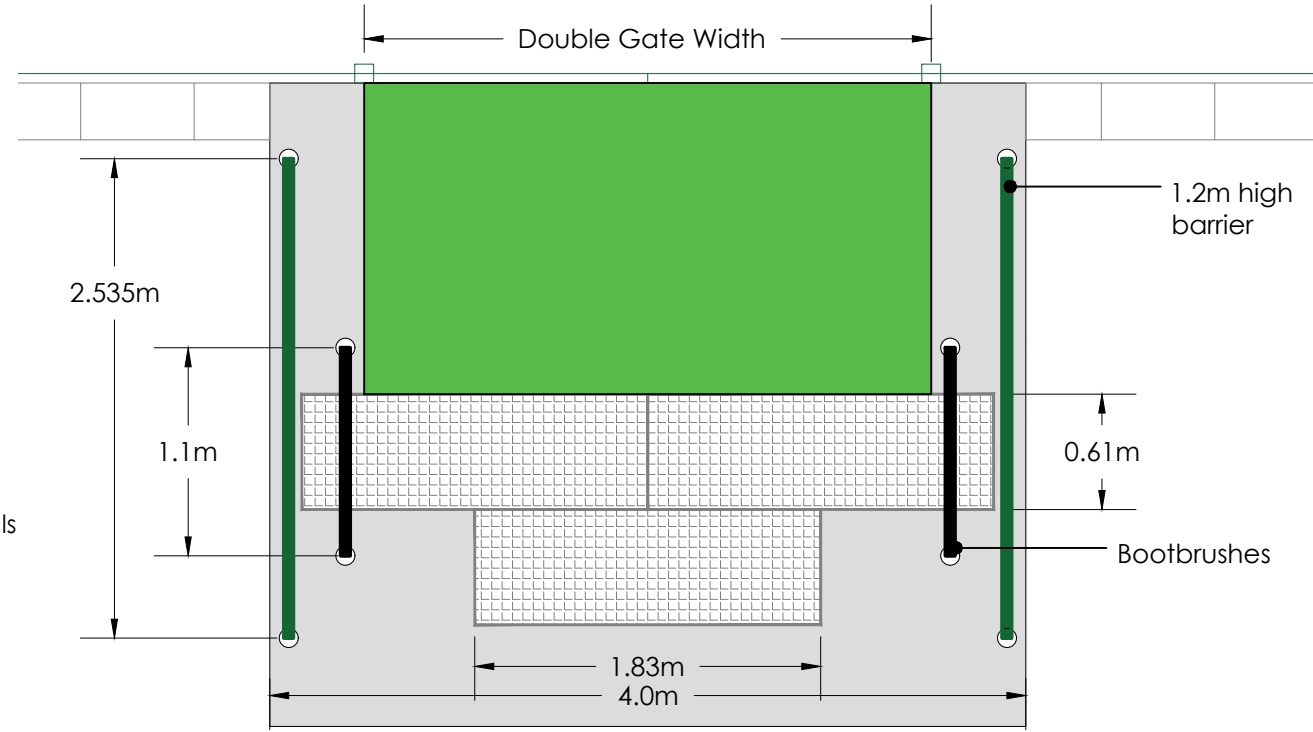

02 TYPICAL DETOX AREA PLAN
SCALE: 1:25

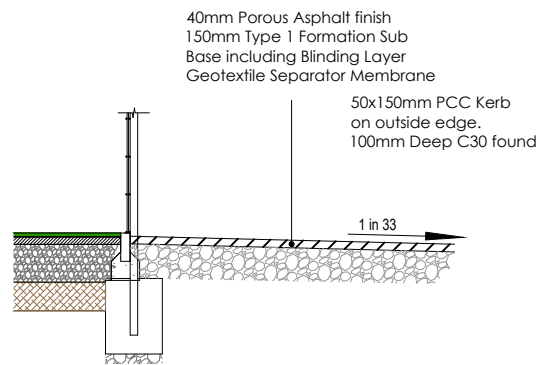

03 STANDARD ACCESS PATH SECTION
SCALE: 1:40

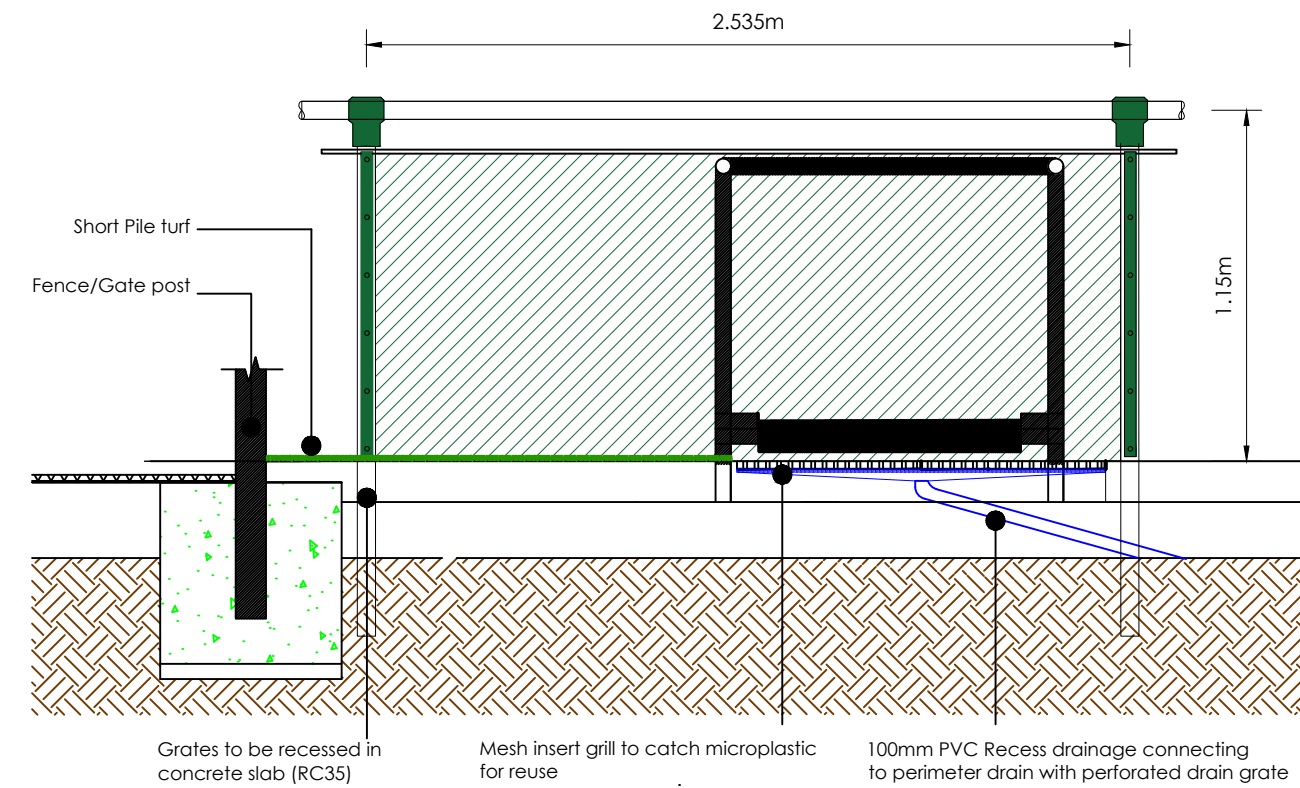

04 TYPICAL DETOX AREA SECTION
SCALE: 1:25

REVISION	DETAILS	BY	DATE	CHECKED

sportslabsconsult
info@sportslabsconsult.com

**KNOCKLYON PARK
CONSTRUCTION DETAILS
CONSTRUCTION OF A NEW ARTIFICIAL PITCH**



Date: 04/2023 Scale: VARES	Job. No. 3096	Drawn by: CH Checked by: DD
-------------------------------	---------------	--------------------------------

B Site Drainage Plan

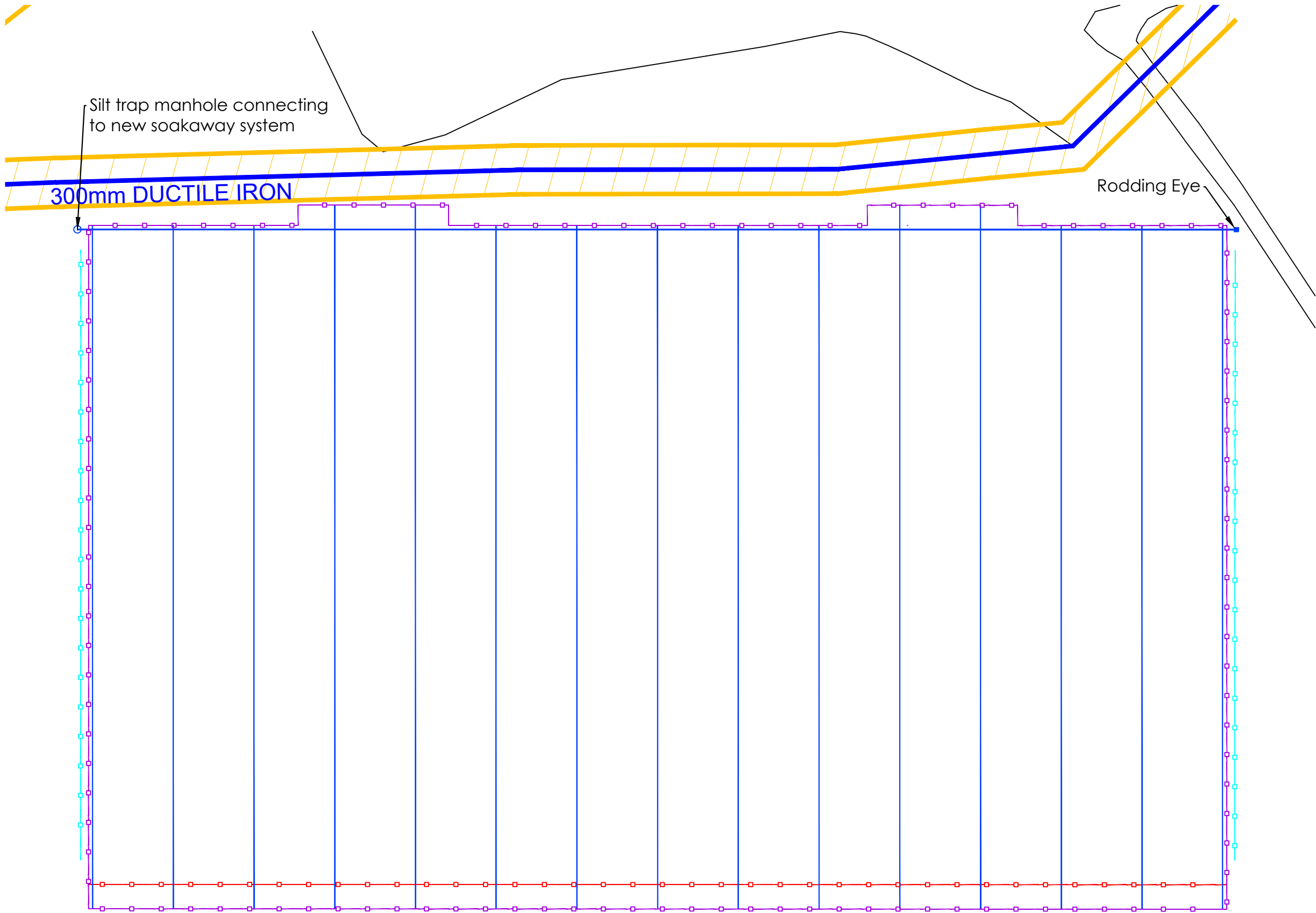

NOTES
 It is the contractors responsibility to check design levels and sizes for compliance. Any discrepancies or errors to be identified to the design team.

- New parallel drainage system
 consisting of;
- Lateral drainage - 80mm diameter at 6.0m centres
 - Carrier drainage - 150mm diameter, location as shown
 - Cut Off drainage - 300mm wide, location as shown

- KEY
- ⌘ Existing Kerb-Line
 - ⊗ Existing Manhole
 - New Drainage Network
 - New Manhole

01 DRAINAGE
 SCALE: 1:500

REVISION	DETAILS	BY	DATE	CHECKED



info@sportslabsconsult.com

**KNOCKLYON PARK
 DRAINAGE LAYOUT
 CONSTRUCTION OF A NEW ARTIFICIAL PITCH**



Date: 04/2023 Scale: 1:500 @ A3	Job. No. 3096	Drawn by: CH Checked by: DD
------------------------------------	----------------------	--------------------------------

NOTES
It is the contractors responsibility to check design levels and sizes for compliance. Any discrepancies or errors to be identified to the design team.

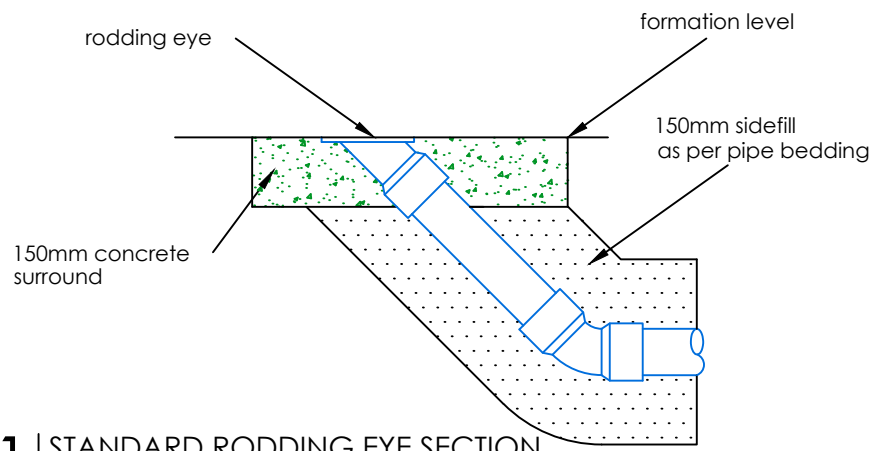

01 | STANDARD RODDING EYE SECTION

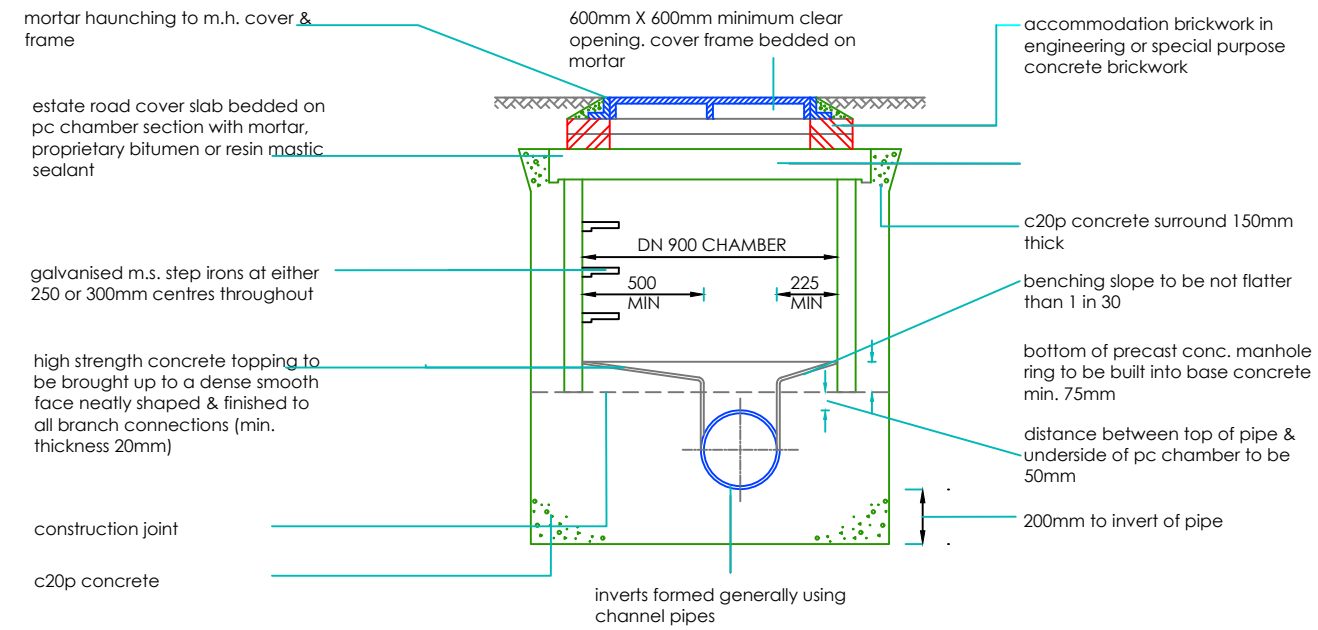

02 | STANDARD MANHOLE SECTION

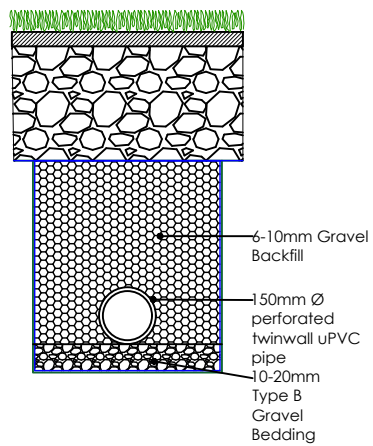

03 | STANDARD LATERAL DRAIN SECTION

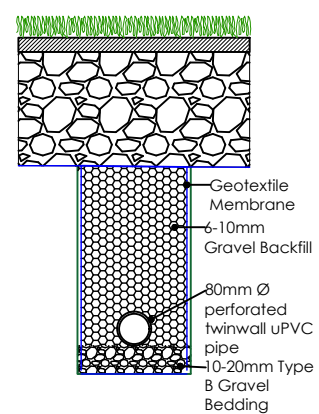

04 | STANDARD CARRIER DRAIN SECTION

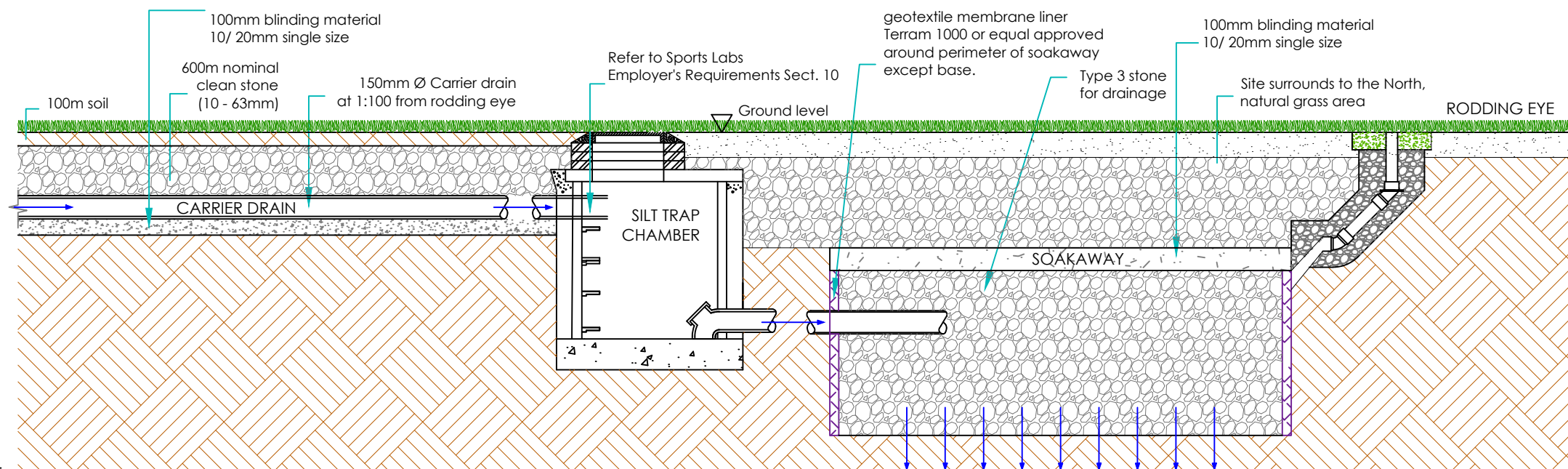

05 | SOAKAWAY SCALE: NTS

REVISION	DETAILS	BY	DATE	CHECKED



KNOCKLYON PARK
DRAINAGE DETAILS
CONSTRUCTION OF A NEW ARTIFICIAL PITCH



Date: 04/2023 Scale: VARES	Job. No. 3096	Drawn by: CH Checked by: DD
-------------------------------	---------------	--------------------------------

C Habitat Map

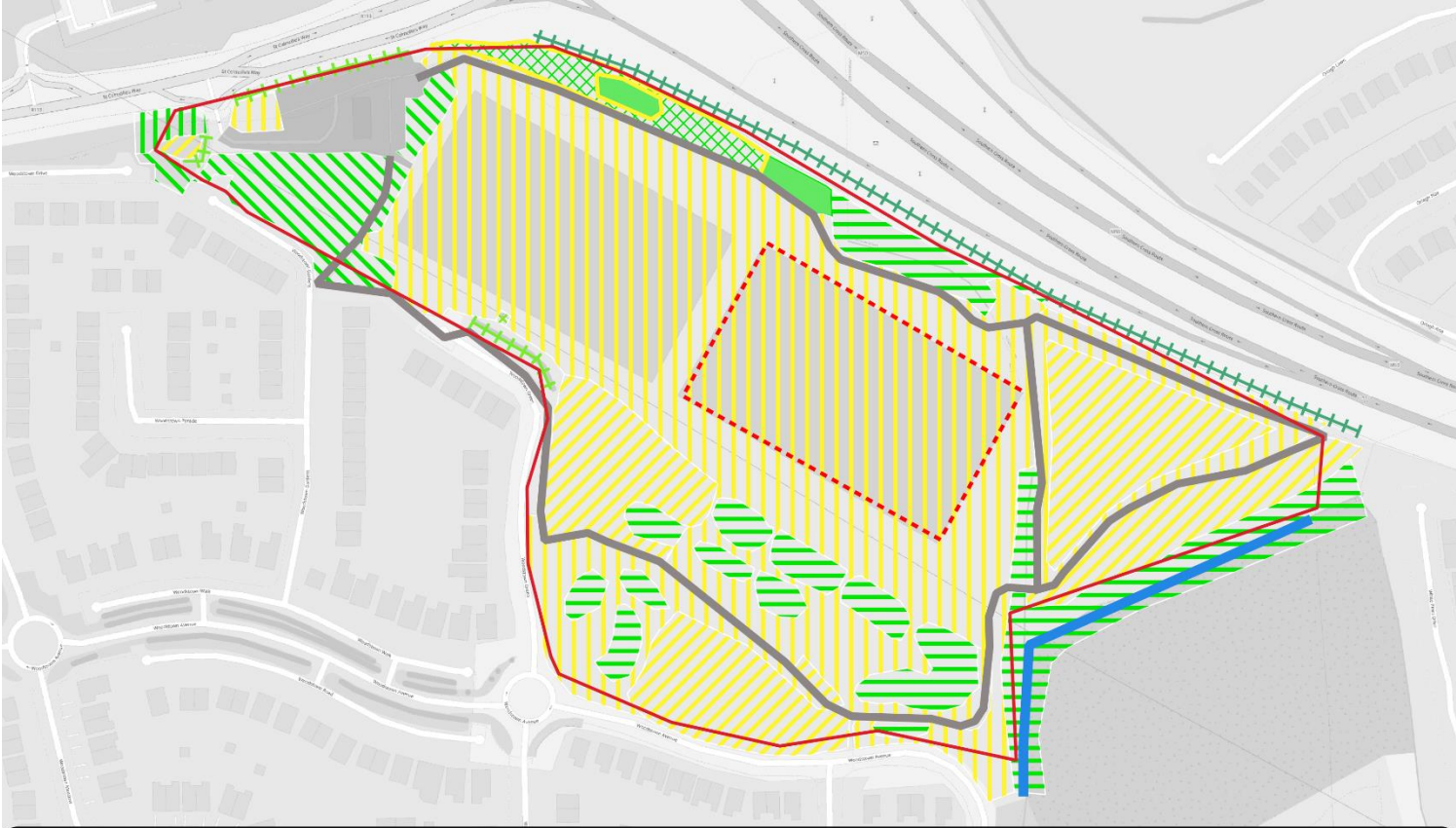

Legend			
— (Red solid line)	Knocklyon Survey Boundary	— (Green dashed line)	WL1
- - - (Red dashed line)	Knocklyon Boundary of Works	— (Green dashed line)	WL2
— (Blue solid line)	FW2	— (Grey solid line)	BL3
— (Green dashed line)	WL1	— (Yellow diagonal hatching)	GS2
— (Green dashed line)	WL2	— (Green diagonal hatching)	WD5
— (Yellow diagonal hatching)	GA2	— (Green diagonal hatching)	WD1
— (Green diagonal hatching)	WS2	— (Green diagonal hatching)	WD2
— (Yellow diagonal hatching)	GS2	— (Green diagonal hatching)	WS1
— (Green diagonal hatching)	WD5	— (Green diagonal hatching)	WS2
— (Yellow diagonal hatching)	GS2/WS1		

0 25 50 m

JBA consulting

D National Biodiversity Data Centre (2023)

D.1 Recent records (within 10 years) of protected species within the 5km of the site

Common Name	Date of Last Record	Designation
Amphibians		
Common Frog <i>Rana temporaria</i>	03/03/2020	EU Habitats Directive >> Annex V Protected Species: Wildlife Acts
Birds		
Barn Owl <i>Tyto alba</i>	21/07/2021	Protected Species: Wildlife Acts Birds of Conservation Concern - Red List
Black-headed Gull <i>Chroicocephalus ridibundus</i>	30/12/2022	Protected Species: Wildlife Acts Birds of Conservation Concern - Amber List
Common Starling <i>Sturnus vulgaris</i>	16/01/2023	Protected Species: Wildlife Acts Birds of Conservation Concern - Amber List
Common Wood Pigeon <i>Columba palumbus</i>	22/01/2023	Protected Species: Wildlife Acts EU Birds Directive >> Annex II & Annex III
Great Cormorant <i>Phalacrocorax carbo</i>	01/09/2017	Protected Species: Wildlife Acts Birds of Conservation Concern - Amber List
Greenfinch <i>Carduelis chloris</i>	11/04/2020	Protected Species: Wildlife Acts Birds of Conservation Concern - Amber List
Grey Wagtail <i>Motacilla cinerea</i>	21/01/2023	Protected Species: Wildlife Acts Birds of Conservation Concern - Red List
Goldcrest <i>Regulus regulus</i>	15/04/2020	Protected Species: Wildlife Acts Birds of Conservation Concern - Red List
Mallard <i>Anas platyrhynchos</i>	30/12/2022	Protected Species: Wildlife Acts EU Birds Directive >> Annex II & Annex III
Mew Gull <i>Larus canus</i>	28/01/2023	Protected Species: Wildlife Acts Birds of Conservation Concern - Amber List
Willow Warbler <i>Larus canus</i>	02/05/2020	Protected Species: Wildlife Acts Birds of Conservation Concern - Amber List
Mammals		
Daubenton's Bat <i>Myotis daubentonii</i>	27/08/2014	EU Habitats Directive >> Annex IV Protected Species: Wildlife Acts
Eurasian Badger <i>Meles meles</i>	28/07/2018	Protected Species: Wildlife Acts
European Otter <i>Lutra lutra</i>	05/12/2022	EU Habitats Directive >> Annex II & Annex IV Protected Species: Wildlife Acts
Lesser Noctule <i>Nyctalus leisleri</i>	24/08/2012	EU Habitats Directive >> Annex IV Protected Species: Wildlife Acts
Pipistrelle <i>Pipistrellus pipistrellus sensu lato</i>	24/08/2012	EU Habitats Directive >> Annex IV Protected Species: Wildlife Acts
Soprano Pipistrelle <i>Pipistrellus pygmaeus</i>	24/08/2012	EU Habitats Directive >> Annex IV Protected Species: Wildlife Acts
West European Hedgehog <i>Erinaceus europaeus</i>	16/05/2021	Protected Species: Wildlife Acts

D.2 Recent records (within 10 years) of invasive species within the 5km of the site

Common Name	Date of Last Record	Designation
Flora		
Butterfly-bush <i>Buddleja davidii</i>	26/03/2022	Medium Impact Invasive Species
Giant Knotweed <i>Fallopia sachalinensis</i>	06/06/2021	High Impact Invasive Species Regulation S.I. 477 (Ireland)
Himalayan Honeysuckle <i>Leycesteria formosa</i>	04/08/2022	Medium Impact Invasive Species
Japanese Knotweed <i>Fallopia japonica</i>	16/08/2022	High Impact Invasive Species Regulation S.I. 477 (Ireland)
Sycamore <i>Acer pseudoplatanus</i>	06/06/2021	Medium Impact Invasive Species
Three-cornered Garlic <i>Allium triquetrum</i>	26/03/2022	Medium Impact Invasive Species Regulation S.I. 477 (Ireland)
Mammals		
Eastern Grey Squirrel <i>Sciurus carolinensis</i>	28/07/2022	High Impact Invasive Species EU Regulation No. 1143/2014 Regulation S.I. 477 (Ireland)
European Rabbit <i>Oryctolagus cuniculus</i>	22/06/2014	Medium Impact Invasive Species

References

- Catchment Science & Management Unit (2021) 3rd Cycle Draft Corrib Bay Catchment Report (HA 30), available: <https://catchments.ie/wp-content/files/catchmentassessments/30%20Corrib%20Catchment%20Summary%20WFD%20Cycle%203.pdf> [accessed 27 March 2023].
- CIEEM (2018) 'Guidelines and checklist for Ecological Impact Assessment in the UK and Ireland: Terrestrial, Freshwater, Coastal and Marine. Chartered Institute of Ecology and Environmental Management'.
- DoEHLG (2009) Appropriate Assessment of Plans and Projects in Ireland Guidance for Planning Authorities., Department of the Environment, Heritage and Local Government, available: <http://www.wicklow.ie/sites/default/files/Manager's%20report%20on%20submissions%20to%20the%20Proposed%20Amendments.pdf> [accessed 12 Jan 2017].
- DoHLGH (2022) 'Draft River Basin Management Plan for Ireland 2022-2027', available: <https://www.gov.ie/en/consultation/2bda0-public-consultation-on-the-draft-river-basin-management-plan-for-ireland-2022-2027> [accessed 02 June 2022].
- EC (2002) Assessment of Plans and Projects Significantly Affecting Natura 2000 Sites: Methodological guidance on the provisions of Article 6(3) and (4) of the Habitats Directive 92/43/EEC, Office for Official Publications of the European Communities, Luxembourg. European Commission, available https://ec.europa.eu/environment/nature/natura2000/management/docs/art6/natura_2000_assess_en.pdf [accessed. 06 Dec 2022]
- EC (2021) Assessment of Plans and Projects Significantly Affecting Natura 2000 Sites: Methodological guidance on the provisions of Article 6(3) and (4) of the Habitats Directive 92/43/EEC, Office for Official Publications of the European Communities, Luxembourg. European Commission, available https://ec.europa.eu/environment/nature/natura2000/management/pdf/methodological-guidance_2021-10/EN.pdf [accessed 06 Dec 2022]
- EEA (2018a) Natura 2000 - Standard Data Form: Glenasmole Valley SAC IE0001209, available: <https://natura2000.eea.europa.eu/Natura2000/SDF.aspx?site=IE0001209> [accessed 27/03/2023]
- EEA (2018b) Natura 2000 - Standard Data Form: Wicklow Mountains SAC IE0002122, available: <https://natura2000.eea.europa.eu/Natura2000/SDF.aspx?site=IE0002122> [accessed 27/03/2023]
- EEA (2020a) Natura 2000 - Standard Data Form: Wicklow Mountains SPA IE0004040, available: <https://natura2000.eea.europa.eu/Natura2000/SDF.aspx?site=IE0004040> [accessed 27/03/2023]
- EEA (2020b) Natura 2000 - Standard Data Form: South Dublin Bay SAC IE0000210, available: <https://natura2000.eea.europa.eu/Natura2000/SDF.aspx?site=IE0000210> [accessed 27/03/2023]
- EEA (2020c) Natura 2000 - Standard Data Form: Sandymount Strand/Tolka Estuary SPA IE0004024, available: <https://natura2000.eea.europa.eu/Natura2000/SDF.aspx?site=IE0004024> [accessed 27/03/2023]
- EEA (2020d) Natura 2000 - Standard Data Form: North Dublin Bay SAC IE0000206, available: <https://natura2000.eea.europa.eu/Natura2000/SDF.aspx?site=IE0000206> [accessed 27/03/2023]
- EEA (2020e) Natura 2000 - Standard Data Form: North Bull Island SPA IE0004006, available: <https://natura2000.eea.europa.eu/Natura2000/SDF.aspx?site=IE0004006> [accessed 27/03/2023]
- EPA (2021) 3rd Cycle Draft Liffey and Dublin Bay Catchment Report (HA 09), available <https://catchments.ie/wp-content/files/catchmentassessments/09%20Liffey%20and%20Dublin%20Bay%20Catchment%20Summary%20WFD%20Cycle%203.pdf> [available, 03 Jan 2023]
- EPA (2022) EPA Maps, available <https://gis.epa.ie/EPAMaps/> [accessed 17 Oct 2022]
- European Commission (Ed.) (2000) Managing Natura 2000 Sites: The Provisions of Article 6 of the 'Habitats' Directive 92/43/EEC, Office for Official Publications of the European Communities: Luxembourg.

European Commission (2007) ‘Guidance document on Article 6 (4) of the “Habitats Directive” 92/43/EEC - Clarification of the concepts of: alternative solutions, imperative reasons of overriding public interest, compensatory measures, overall coherence, opinion of the commission.’

European Commission, Directorate-General for the Environment, Oxford Brookes University, Impacts Assessment Unit (Eds.) (2002) Assessment of Plans and Projects Significantly Affecting Natura 2000 Sites: Methodological Guidance on the Provisions of Article 6(3) and (4) of the Habitats Directive 92/43/EEC, EUR-OP: Luxembourg.

Fossitt, J.A. (2000) A Guide to Habitats in Ireland, Heritage Council of Ireland series, Heritage Council/Chomhairle Oidhreachta: Kilkenny.

GSI (2022) Geological Survey Ireland Spatial Resources [online], available: <https://dcenr.maps.arcgis.com/apps/MapSeries/index.html?appid=a30af518e87a4c0ab2fbde2aaac3c228> [accessed 30 September 2022].

Irish Water (2018) ‘Greater Dublin Drainage Strategy - Overview & Future Strategic Needs’, available: https://www.ringsendwwtpupgrade.ie/planning-sites/ringsend-planning/docs/planning-documents/technical-reports/180601_RGD%20Planning%20App%20-%20GDDS%20-%20Overview.pdf [accessed 18 Jun 2019].

Irish Water (2021) Ringsend Wastewater Treatment Plant Upgrade Project [online], Irish Water, available: <https://www.water.ie/projects-plans/ringsend/> [accessed 12 Jan 2021].

NPWS (2013a) Site Synopsis Glenasmole Valley SAC 001209, available <https://www.npws.ie/sites/default/files/protected-sites/synopsis/SY001209.pdf>, [accessed 27/03/2023]

NPWS (2013b) Conservation Objectives: South Dublin Bay SAC 000210. Version 1. National Parks and Wildlife Service, Department of Arts, Heritage and the Gaeltacht.

NPWS (2013c) Site Synopsis North Dublin Bay SAC 000206, available <https://www.npws.ie/sites/default/files/protected-sites/synopsis/SY000206.pdf>, [accessed 27/03/2023]

NPWS (2013d) Conservation Objectives: North Dublin Bay SAC 000206. Version 1. National Parks and Wildlife Service, Department of Arts, Heritage and the Gaeltacht.

NPWS (2014a) Site Synopsis Wicklow Mountains SPA 004040, available <https://www.npws.ie/sites/default/files/protected-sites/synopsis/SY004040.pdf>, [accessed 27/03/2023]

NPWS (2014b) Site Synopsis North Bull Island SPA 004006, available <https://www.npws.ie/sites/default/files/protected-sites/synopsis/SY004006.pdf>, [accessed 27/03/2023]

NPWS (2015a) Site Synopsis South Dublin Bay SAC 000210, available <https://www.npws.ie/sites/default/files/protected-sites/synopsis/SY000210.pdf>, [accessed 27/03/2023]

NPWS (2015b) Site Synopsis South Dublin Bay and River Tolka SPA 004024, available <https://www.npws.ie/sites/default/files/protected-sites/synopsis/SY004024.pdf>, [accessed 27/03/2023]

NPWS (2015c) Conservation Objectives: South Dublin Bay and River Tolka Estuary SPA 004024. Version 1. National Parks and Wildlife Service, Department of Arts, Heritage and the Gaeltacht.

NPWS (2016) Conservation Objectives: North Bull Island SPA 004006. Version 1. National Parks and Wildlife Service, Department of Arts, Heritage and the Gaeltacht

NPWS (2017a) Site Synopsis Wicklow Mountains SAC 002122, available <https://www.npws.ie/sites/default/files/protected-sites/synopsis/SY002122.pdf>, [accessed 27/03/2023]

NPWS (2017b) Conservation Objectives: Wicklow Mountains SAC 002122. Version 1. National Parks and Wildlife Service, Department of Arts, Heritage, Regional, Rural and Gaeltacht Affairs.

NPWS (2021) Conservation Objectives: Glenasmole Valley SAC 001209. Version 1. National Parks and Wildlife Service, Department of Housing, Local Government and Heritage

NPWS (2022) Conservation objectives for Wicklow Mountains SPA [004040]. First Order Site-specific Conservation Objectives Version 1.0. Department of Housing, Local Government and Heritage

NRA (2009) Ecological Surveying Techniques for Protected Flora and Fauna during the Planning of National Road Schemes, available <https://www.tii.ie/technical-services/environment/planning/Ecological-Surveying-Techniques-for-Protected-Flora-and-Fauna-during-the-Planning-of-National-Road-Schemes.pdf> [accessed 15 Nov 2022]

NRA (2011) Guidelines for the Treatment of Air Quality During the Planning and Construction of National Road Schemes, available <https://www.tii.ie/technical-services/environment/planning/Guidelines-for-the-Treatment-of-Air-Quality-during-the-Planning-and-Construction-of-National-Road-Schemes.pdf> [accessed 15 Nov 2022]

OPR (2021) 'OPR Practice Note PN01 - Appropriate Assessment Screening for Development Management'.

RBMP, 2018. River Basin Management Plan for Ireland 2018 -2021. Department of Housing, Planning and Local Government

Parnell, J. & Curtis, T.G. (2012). Webb's an Irish Flora.

SDCC (2022a) South Dublin County Development Plan 2022-2028 Adopted Plan, available <https://www.sdcc.ie/en/devplan2022/adopted-plan/> [accessed 06 March 2023].

SDCC (2022b) Natura Impact Report for the South Dublin County Development Plan 2022-2028, available: <https://www.sdcc.ie/en/devplan2022/adopted-plan/environmental-reports/natura-impact-report.pdf> [accessed 06 March 2023].

Stace. C (2019) The New Flora of the British Isles 4th Edition

Windfinder.com (2022) Windfinder.Com - Wind and Weather Statistic Casement Aerodrome [online], Windfinder.com, available: https://www.windfinder.com/forecast/churchtown_dublin [accessed 15 Dec. 22].

JBA
consulting

Offices at

Dublin

Limerick

Registered Office

24 Grove Island

Corbally

Limerick

Ireland

t: +353 (0) 61 345463

e: info@jbaconsulting.ie

JBA Consulting Engineers and
Scientists Limited

Registration number 444752

JBA Group Ltd is certified to:

ISO 9001:2015

ISO 14001:2015

ISO 27001:2013



Visit our website
www.jbaconsulting.ie