

ISSUE CODE		SIGNATURE:	Issue Code	P																
P	PRELIMINARY ONLY		Dispatch Code																	
I	INFORMATION ONLY	ISSUE DATE:																		
S	FOR SIGNOFF	DISTRIBUTED TO	Attention																	
PL	PLANNING	CLIENT	South Dublin County Council																	
T	TENDER	ARCHITECT	BKD Architects																	
C	CONSTRUCTION	TRAFFIC	DBFL																	
DISPATCH CODE		PLANNING																		
H	HAND/MESSANGER	LANDSCAPE ARCHITECT	RMDA																	
X	COURIER	SURVEY	Land Surveys																	
M	MAIL/FACSIMILE	STRUCTURAL	DBFL																	
R	RECEIV. COLLECT.	CIVILS	DBFL																	
MEDIA CODE		MECH & ELEC.	OCSC																	
P#	PRINTS (No. off)	QUANTITY SURVEYOR																		
N#	NEGS (No. off)	CGI's																		
D	DISKETTE, CDROM	DAYLIGHT/SUNLIGHT																		
G	GENERAL DOC																			
EM	E-MAIL																			
		LOCAL AUTHORITY	South Dublin County Council																	
DRG. NO.	DRAWING TITLE	Issued	D	18																
			M	12																
			Y	23																
		Scale	Size	REVISION																
Drawings																				
6168A-P-001	Site Location Map	1:1000	A1																	
6168A-P-101	Site Layout Plan	1:500	A1																	
6168A-P-102	Taking in charge Layout	1:500	A1																	
6168A-P-200	Street Elevations	1:200	A0																	
6168A-P-300	Site Section	1:200	A0																	
6168A-P-400	Unit Type B - Plans, Elevations & Section	1:100	A1																	
6168A-P-401	Unit Type B1 - Plans, Elevations & Section	1:100	A1																	
6168A-P-402	Unit Type B2 - Plans, Elevations & Section	1:100	A1																	
6168A-P-403	Unit Type D - Plans, Elevations & Section	1:100	A1																	
6168A-P-404	Unit Type E2 - Plans, Elevations & Section	1:100	A1																	
6168A-P-405	Unit Type G - Plans, Elevations & Section	1:100	A1																	
6168A-P-406	Unit Type J - Plans, Elevations & Section	1:100	A1																	
6168A-P-407	Duplex Block Type K, L & L1 - Plans, Elevations & Section	1:100	A1																	
6168A-P-408	Duplex Block Type K1, L4 & L5 - Plans, Elevations & Section	1:100	A1																	
6168A-P-409	Duplex Block Type K2, L6 & L7 - Plans, Elevations & Section	1:100	A1																	
6168A-P-410	Unit Type M & N - Plans, Elevations & Section	1:100	A1																	
6168A-P-411	Unit Type M1 & N1 - Plans, Elevations & Section	1:100	A1																	
6168A-P-412	Unit Type M2 & N2 - Plans, Elevations & Section	1:100	A1																	
6168A-P-413	Unit Type M3 & N3 - Plans, Elevations & Section	1:100	A1																	
6168A-P-500	ESB Substation	1:50	A3																	
6168A-P-501	Bin Store Type 1	1:50	A3																	
6168A-P-502	Bin Store Type 2	1:50	A3																	
6168A-P-503	Bike Shelters	1:50	A3																	
Reports and Supporting Documents																				
6168A	Overall Schedule of Areas	N/A	A3																	
6168A	Housing Quality Assessment	N/A	A3																	
6168A	Planning Derogation Architectural Design Rationale	N/A	A3																	

ISSUED FOR CONSTRUCTION U.N.O.

ALL DWGS SUPERSEDED BY THIS ISSUE SHOULD BE MARKED 'SUPERCEDED' AND REMOVED FROM USE. VERIFY ALL ISSUES ON THIS SCHEDULE HAVE BEEN RECEIVED.

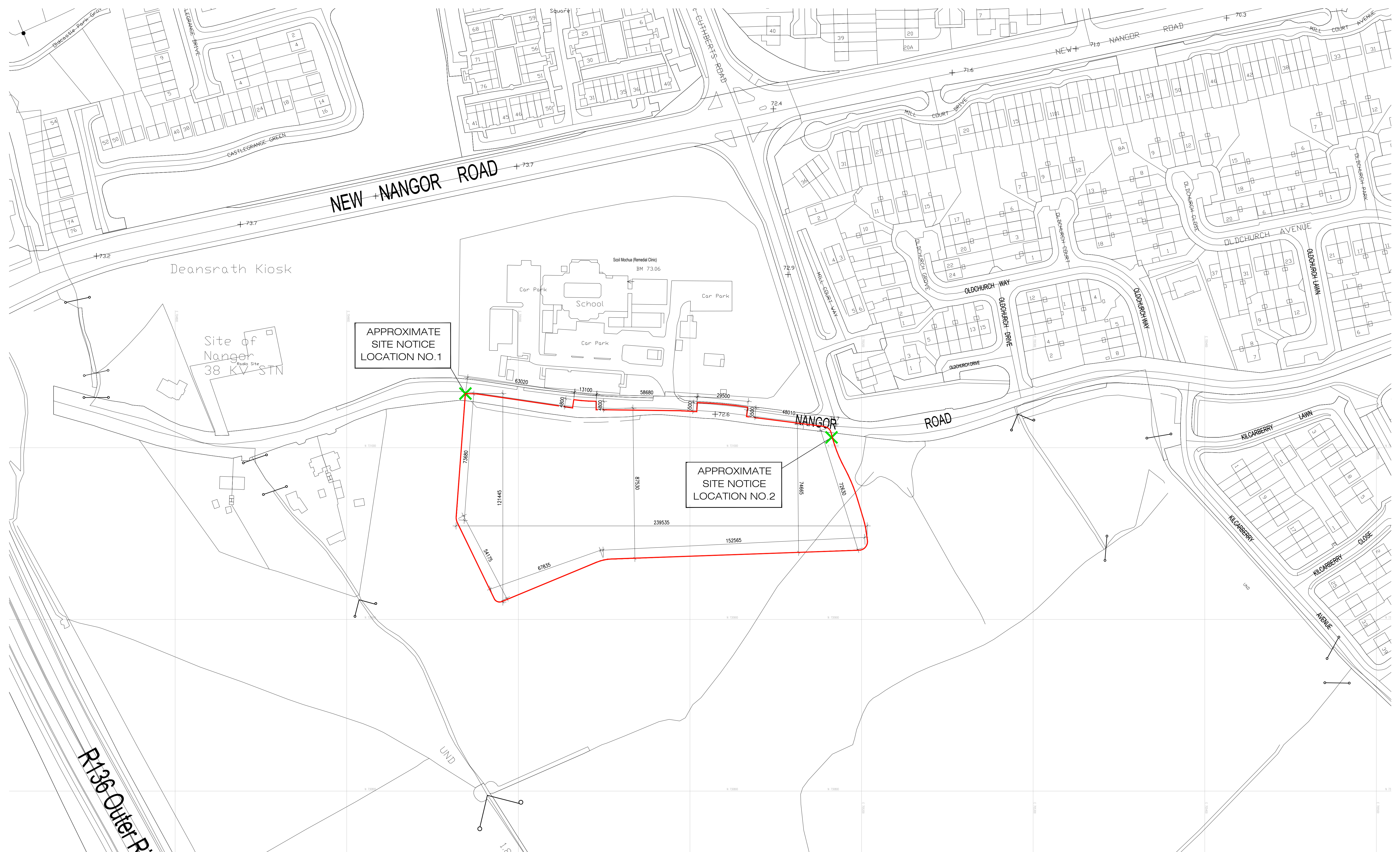

01 SITE LOCATION MAP
P-001 1:1000 @A1

© ORDNANCE SURVEY SHEET REF. NUMBERS: 3326-A, 3326-C, 3326-7 and 3326-13
REPRODUCED UNDER LICENCE NUMBER: CYAL50322051
APPLICATION SITE BOUNDARY (RED LINE)
ALL LEVELS ARE OS DATUM - MALIN HEAD

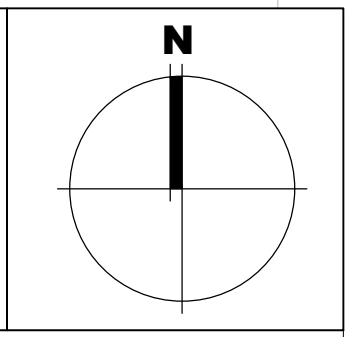

- Notes**
1. Copyright Reserved
 2. Work to figured dimensions only. Do not scale drawing
 3. The contractor is responsible for checking all levels and dimensions on site and shall refer all discrepancies to the Architect
 4. Where appropriate, for details of r.c. structure, or mechanical and electrical details, see Engineers drawings
 5. Proprietary items shall be fixed in strict accordance with manufacturers instructions.
 6. Sizes of proprietary items shall be checked with manufacturer.
 7. The contractor shall be responsible for the coordination of structures, finishes and services.

Issue Status	
Progress	■
Planning Application	■
Fire Cert	
Disability Cert	
Tender	
Construction	
As Built	

No.	Date	Revision	Initials
01	09/11/23	Draft Issue For Discussion	ED
02	20/11/23	PART 8 ISSUE	ED

Project	RESIDENTIAL DEVELOPMENT AT UPPER NANGOR ROAD, KILCARRBERY, CO. DUBLIN
Drawing Title	SITE LOCATION MAP
Drawing No	6168A-P-001
Scale	1:1000@A1
Rev	02
Drawn	ED
Date	20/11/23

6-7 HARDCOURT TERRACE, DUBLIN 2, IRELAND
t: +353-1-678 2400 f: +353-1-678 7366
www.bkd.ie
bkd architects
BURKE-KENNEDY DOYLE



01 SITE PLAN
P-101 1:500 @A1

- Notes**
1. Copyright Reserved
 2. Work to agreed dimensions only. Do not scale drawing
 3. The contractor is responsible for checking all levels and dimensions on site and shall refer all discrepancies to the Architect
 4. Where appropriate, for details of r.c. structure, or mechanical and electrical details, see Engineers drawings
 5. Proprietary items shall be fixed in strict accordance with manufacturers instructions.
 6. Sizes of proprietary items shall be checked with manufacturer.
 7. The contractor shall be responsible for the coordination of structure, finishes and services.

Issue Status	Progress
Planning Application	■
Fire Cert	
Disability Cert	
Tender	
Construction	
As Built	
Information Only	

No	Date	Revision
10	20.11.23	PART 8 ISSUE

Initials	No	Date	Revision
ED	01	13.07.23	Draft Issue For Discussion
ED	02	27.07.23	Draft Issue For Discussion
ED	03	10.08.23	Draft Issue For Discussion
ED	04	05.09.23	Draft Issue For Discussion
ED	05	27.09.23	Draft Issue For Discussion
ED	06	16.10.23	Frozen Layout as Baseline for Part 8 Pack
ED	07	24.10.23	Adjusted Pump-station Layout as Baseline for Part 8 Pack
ED	08	02.11.23	Draft Part 8 Pack
ED	09	10.11.23	Draft Part 8 Pack - BKD Updated Unit Levels

Project	Revision	Date
6-7 HARDCOURT TERRACE, DUBLIN 2, IRELAND	10	20/11/23

Project	Revision	Date
RESIDENTIAL DEVELOPMENT AT UPPER NANGOR ROAD, KILCARBERY, CO. DUBLIN	10	20/11/23
Drawing Title	SITE LAYOUT PLAN	
Drawing No	6168A-P-101	

bkdarchitects
BURKE-KENNEDY DOYLE
www.bkd.ie

Legend:

 Proposed Areas to be Taken In Charge

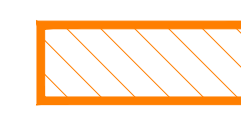
 Proposed Areas to be Placed Under Management

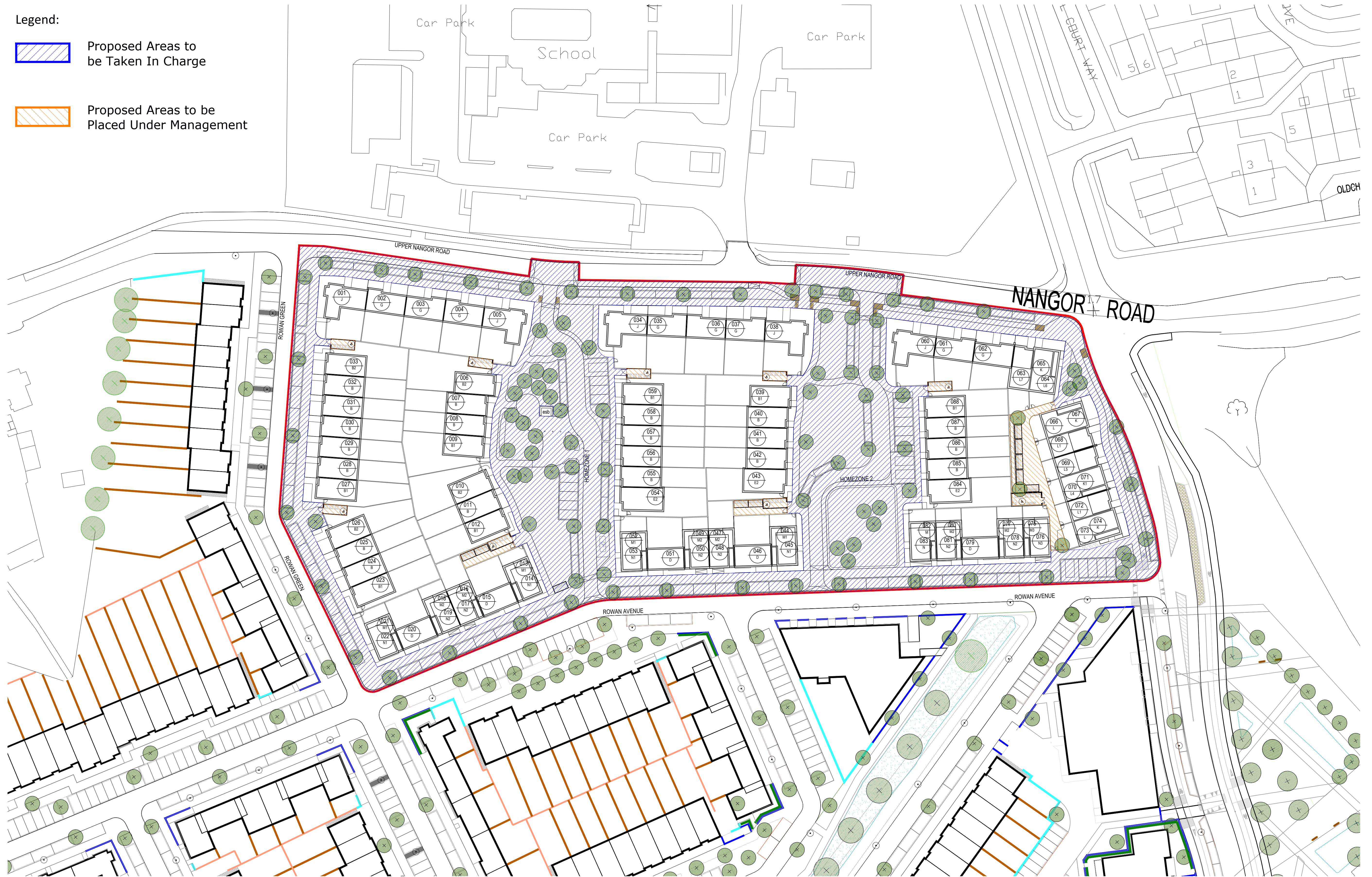

01 TAKING IN CHARGE LAYOUT
1:500 @A1

- Notes
1. Copyright Reserved
 2. Work to agreed dimensions only. Do not scale drawing
 3. The contractor is responsible for checking all levels and dimensions on site and shall refer all discrepancies to the Architect
 4. Where appropriate, for details of r.c. structure, or mechanical and electrical details, see Engineers drawings
 5. Proprietary items shall be fixed in strict accordance with manufacturers instructions.
 6. Sizes of proprietary items shall be checked with manufacturer.
 7. The contractor shall be responsible for the coordination of structure, finishes and services.

Issue Status
Progress
Planning Application
Fire Cert
Disability Cert
Tender
Construction
As Built
Information Only

No.	Date	Revision	Initials
01	09/11/23	Draft Issue For Discussion	ED
01	20/11/23	PART B ISSUE	ED

Project	RESIDENTIAL DEVELOPMENT AT UPPER NANGOR ROAD, KILCARBERY, CO. DUBLIN
Drawing Title	TAKING IN CHARGE LAYOUT
Drawing No	6168A-P-102
Scale	1:500@A1
Rev	02
Drawn	ED
Date	20/11/23

6-7 HARCOURT TERRACE, DUBLIN 2, IRELAND
 T: +353 1 678 2400 F: +353 1 678 7395
 www.bkd.ie

bkd architects
 BURKE-KENNEDY DOYLE

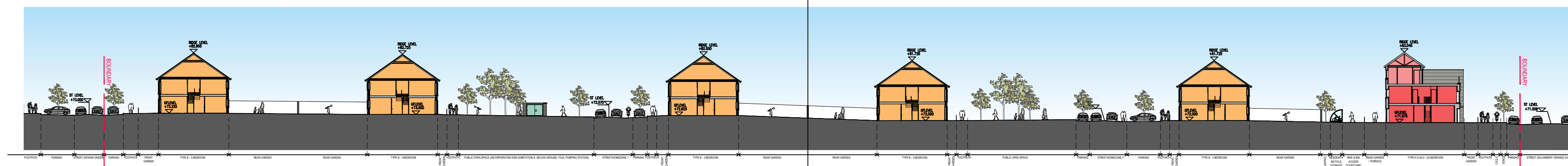

01 Proposed Site Section A-A
P-300 1:500 @ A1

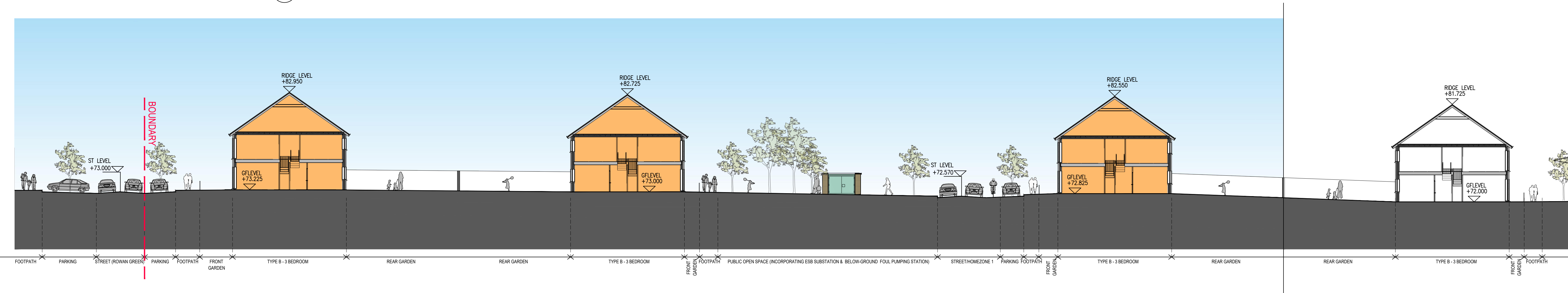

02 Proposed Site Section A-A - Western Half
P-300 1:200 @ A1

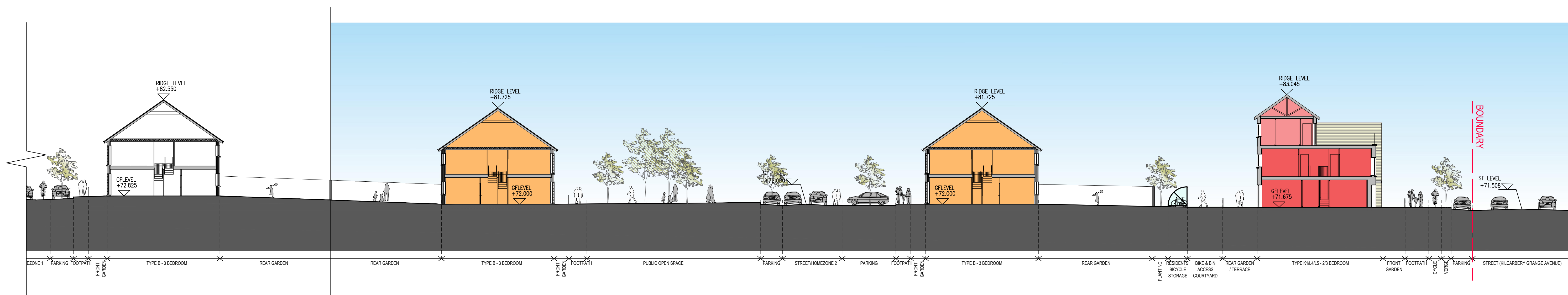

03 Proposed Site Section A-A - Eastern Half
P-300 1:200 @ A1



09 Key Plan
P-300 NTS @ A1

- Notes**
1. Copyright Reserved
 2. Work to signed dimensions only. Do not scale drawing
 3. The contractor is responsible for checking all levels and dimensions on site and shall refer all discrepancies to the Architect
 4. Where appropriate, for details of r.c. structure, or mechanical and electrical details, see Engineers drawings
 5. Proprietary items shall be fixed in strict accordance with manufacturers instructions.
 6. Sizes of proprietary items shall be checked with manufacturer.
 7. The contractor shall be responsible for the coordination of structure, finishes and services.

Issue Status	
Progress	
Planning Application	■
Fire Cert	
Disability Cert	
Tender	
Construction	
As Built	
Information Only	

No.	Date	Revision	Initials
01	09/11/23	Draft Issue For Discussion	ED
02	23/11/23	Part 8 Issue	ED

Project	RESIDENTIAL DEVELOPMENT AT UPPER NANGOR ROAD, KILCARRIBY, CO. DUBLIN		
Drawing Title	SITE SECTION		
Drawing No	6168A-P-300		
Scale	1:200@A0	Rev	02
Drawn	RT, ED	Date	23/11/23

6-7 HARDCOURT TERRACE, DUBLIN 2, IRELAND
t +353-1-618 2400 f +353-1-676 7396
www.bkd.ie

bkdarchitects
BURKE-KENNEDY DOYLE

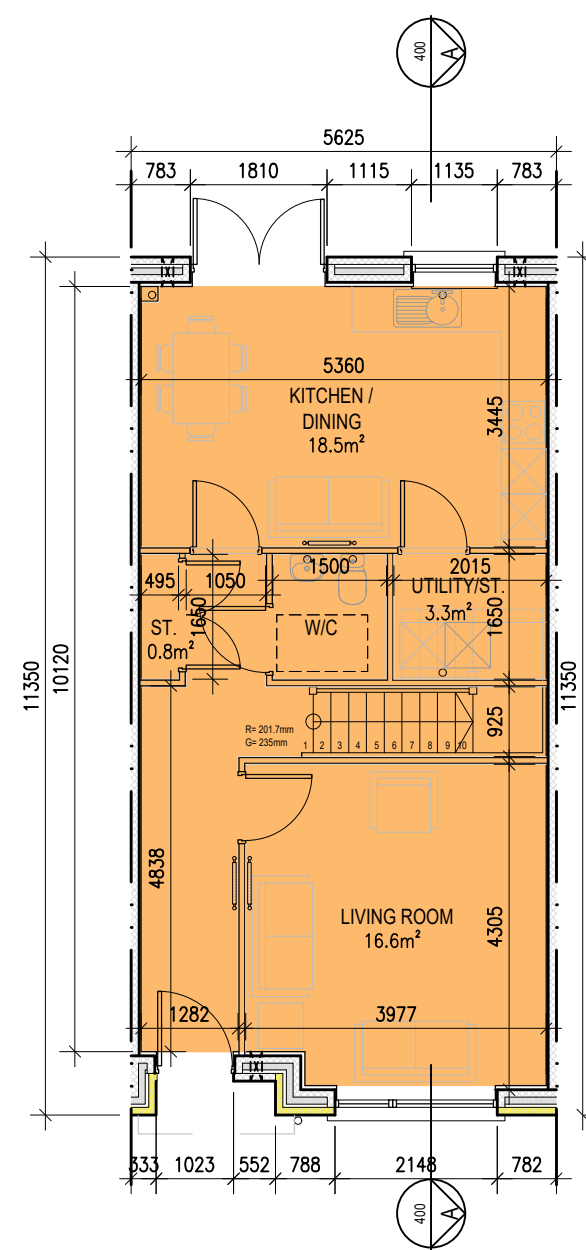

01 TYPE B - GROUND FLOOR PLAN
1:100@A1

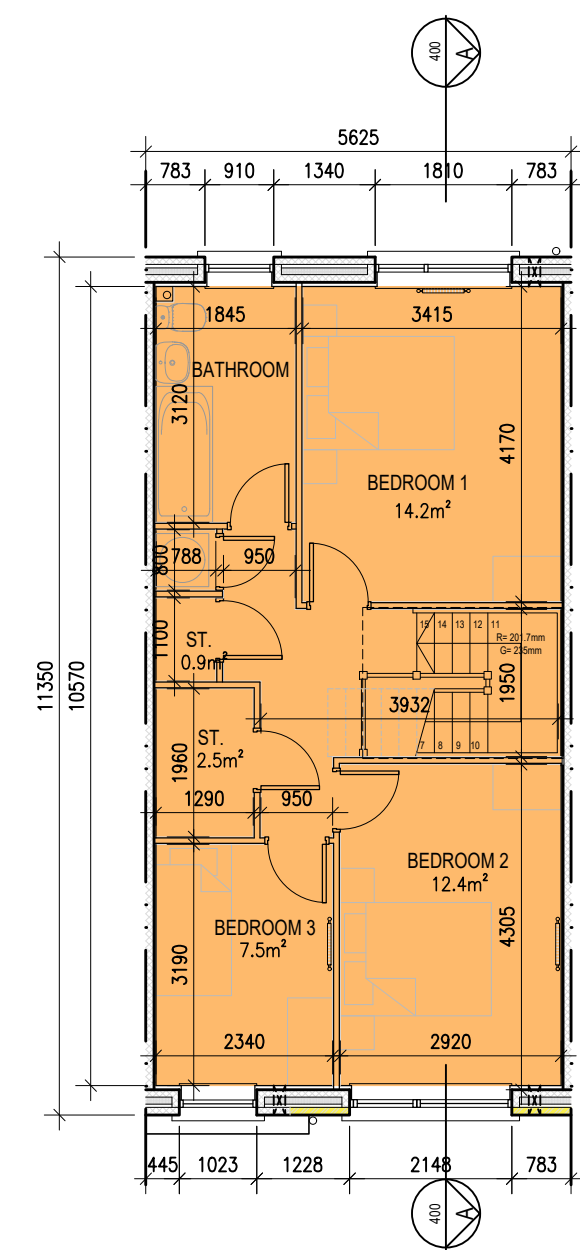

02 TYPE B - FIRST FLOOR PLAN
1:100@A1

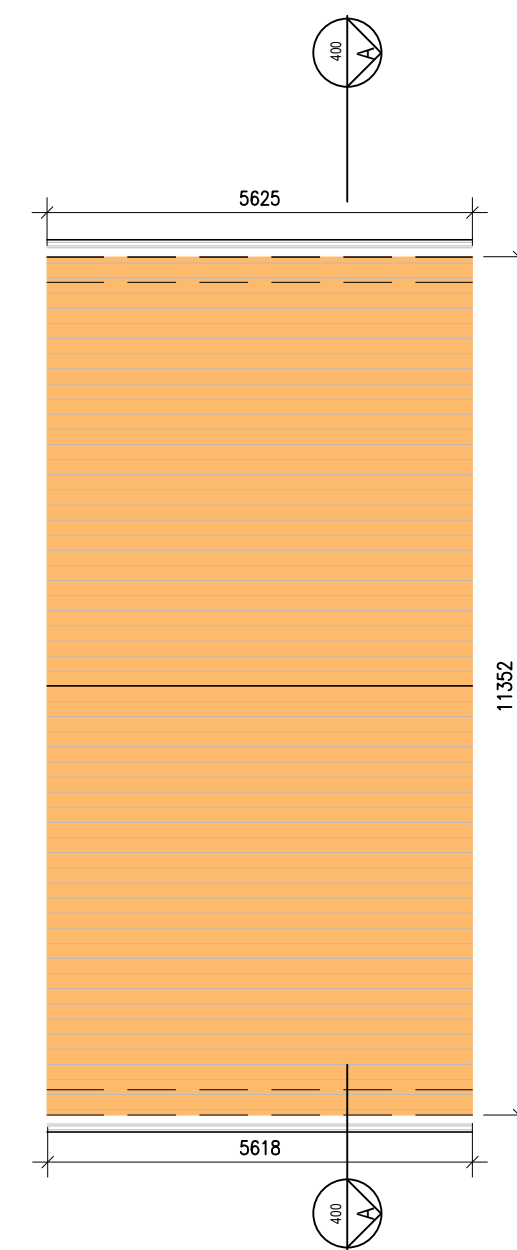

03 TYPE B - ROOF PLAN
1:100@A1

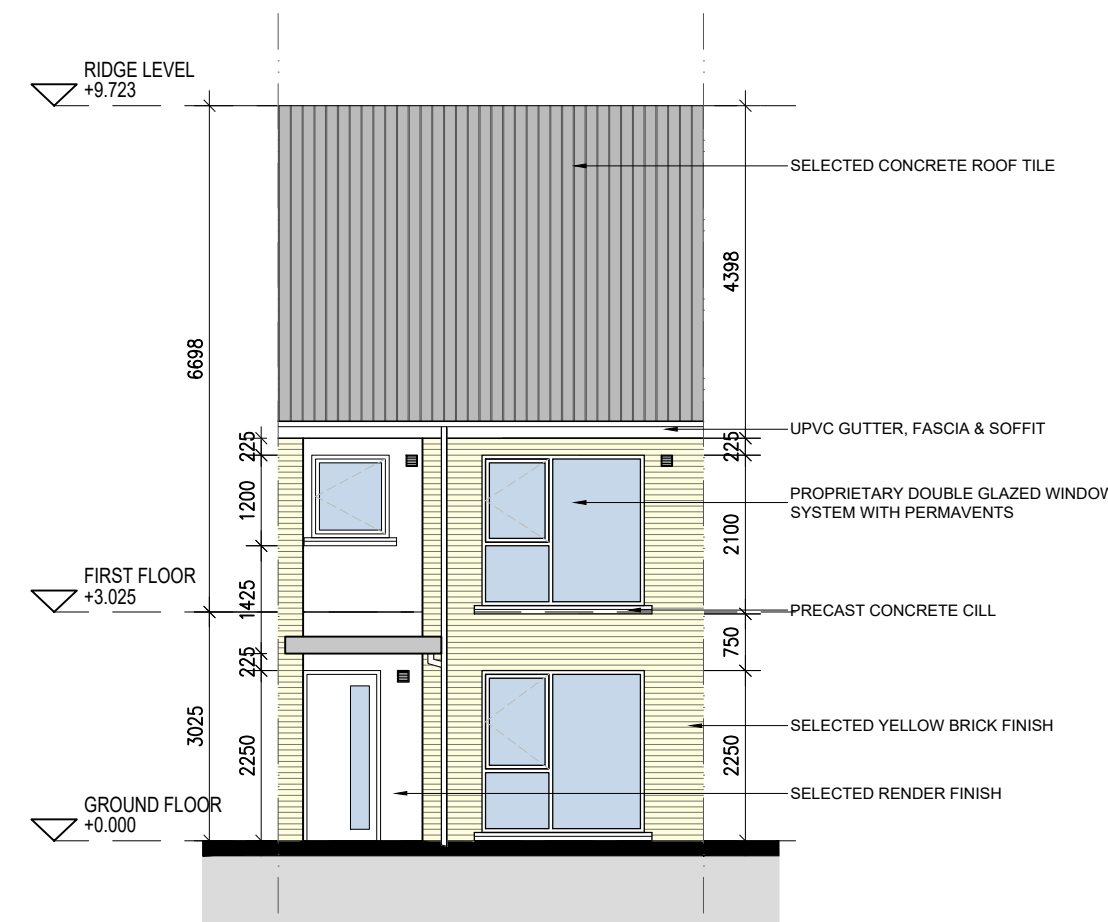

04 TYPE B - FRONT ELEVATION / ROWAN
1:100@A1

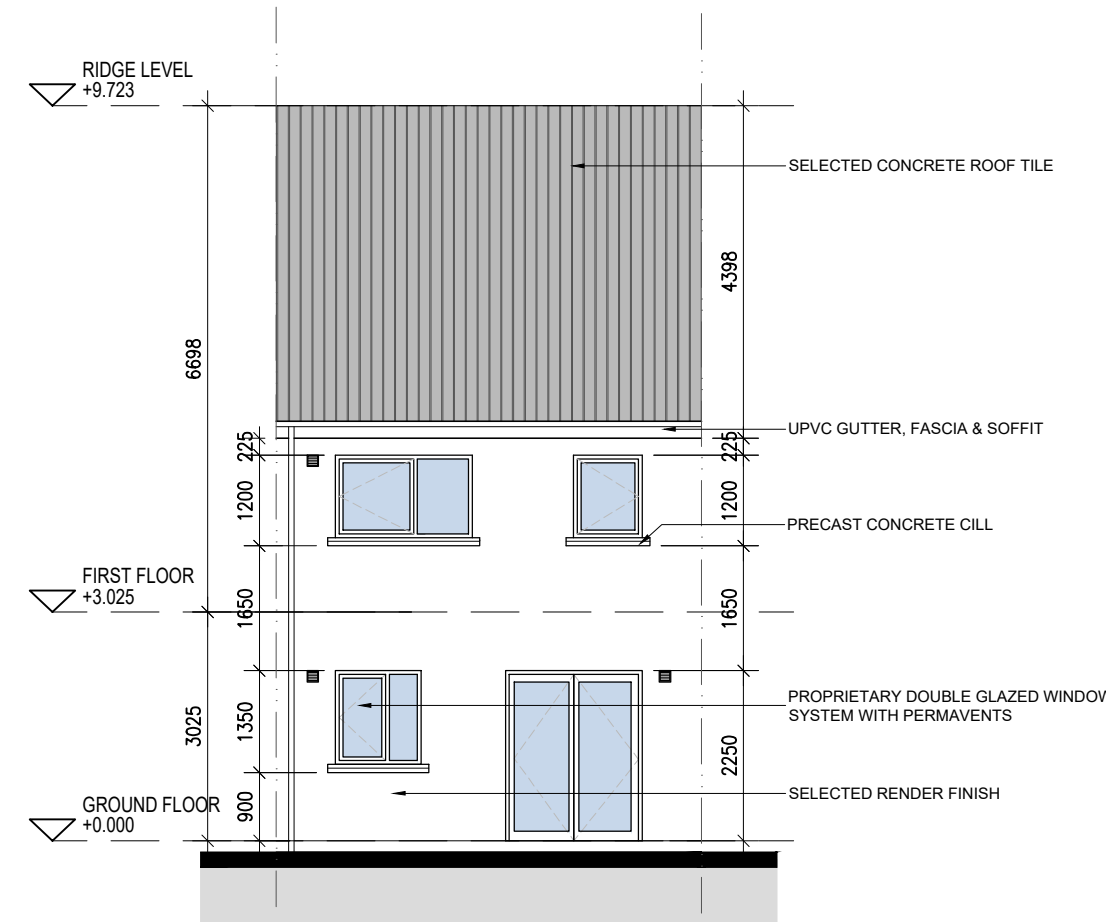

05 TYPE B - REAR ELEVATION
1:100@A1

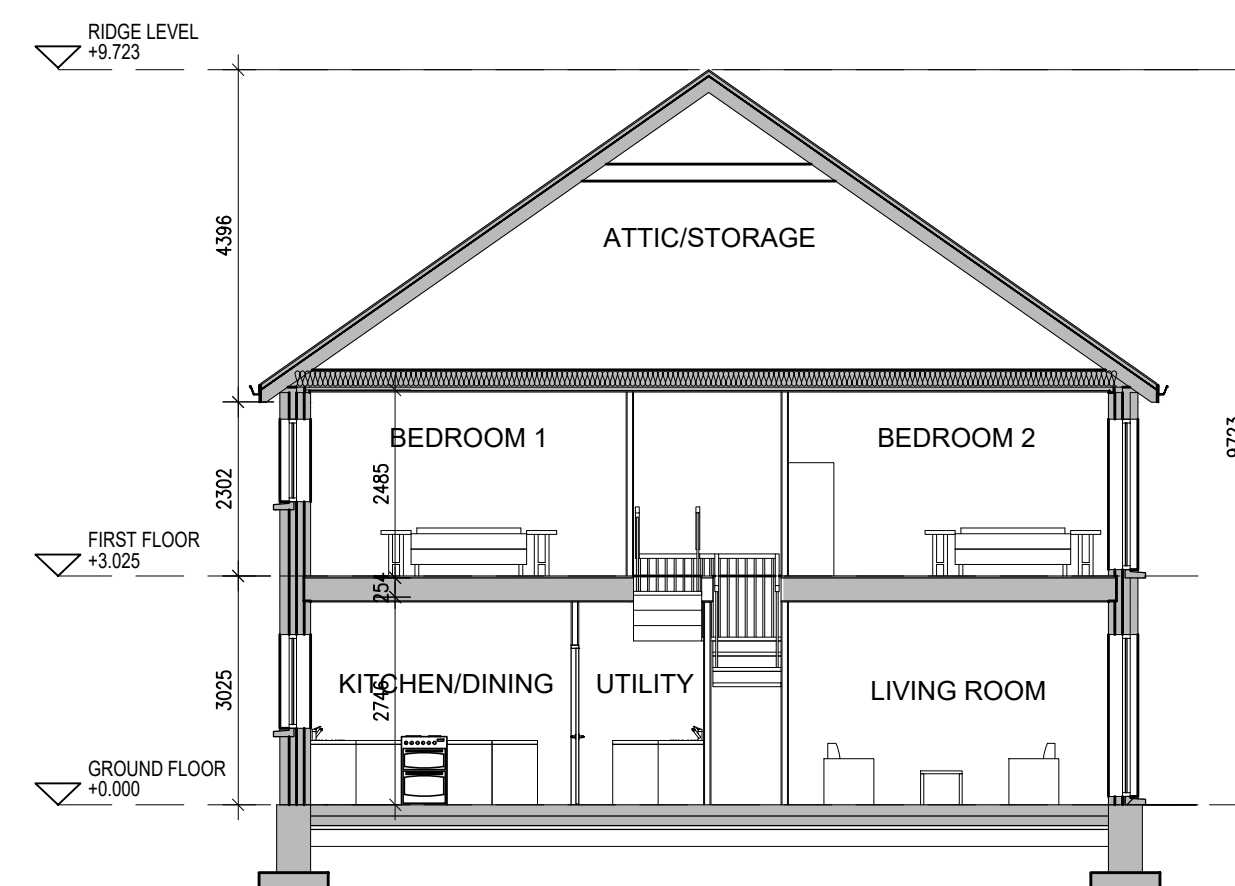

06 TYPE B - SECTION A-A
1:100@A1

REFER ALSO TO SITE SETTING-OUT PLANS AND ELEVATIONS

B	3 BED - 5 PERSON HOUSE	GROUND FLOOR	FIRST FLOOR	N/A	TOTAL AREA
		55.6m ²	56.7m ²		112.3m ²

OS DATUM - MALIN HEAD

Notes	Issue Status	No.	Date	Revision	Initials
1. Copyright Reserved	Progress	01	13/11/23	Draft Issue For Discussion	ED
2. Work to figured dimensions only. Do not scale drawing	Planning Application	02	23/11/23	Part 8 Issue	ED
3. The contractor is responsible for checking all levels and dimensions on site and shall refer all discrepancies to the Architect	Fire Cert				
4. Where appropriate, for details of r.c. structure, or mechanical and electrical details, see Engineers drawings	Disability Cert				
5. Proprietary items shall be fixed in strict accordance with manufacturers instructions.	Tender				
6. Sizes of proprietary items shall be checked with manufacturer.	Construction				
7. The contractor shall be responsible for the coordination of structure, finishes and services.	As Built				
	Information Only				

Project	RESIDENTIAL DEVELOPMENT AT UPPER NANGOR ROAD, KILCABERY, CO. DUBLIN		6-7 HARPCOURT TERRACE, DUBLIN 2, IRELAND T: +353-1-6182400 F: +353-1-6767396 www.bkd.ie		
Drawing Title	UNIT TYPE B - PLANS, ELEVATIONS & SECTION		bkd architects BURKE-KENNEDY DOYLE		
Drawing No	6168A-P-400				
Scale	1:100@A1	Rev	02	Drawn	ED
		Date	23/11/23		



00 KEY PLAN
1:100@A1

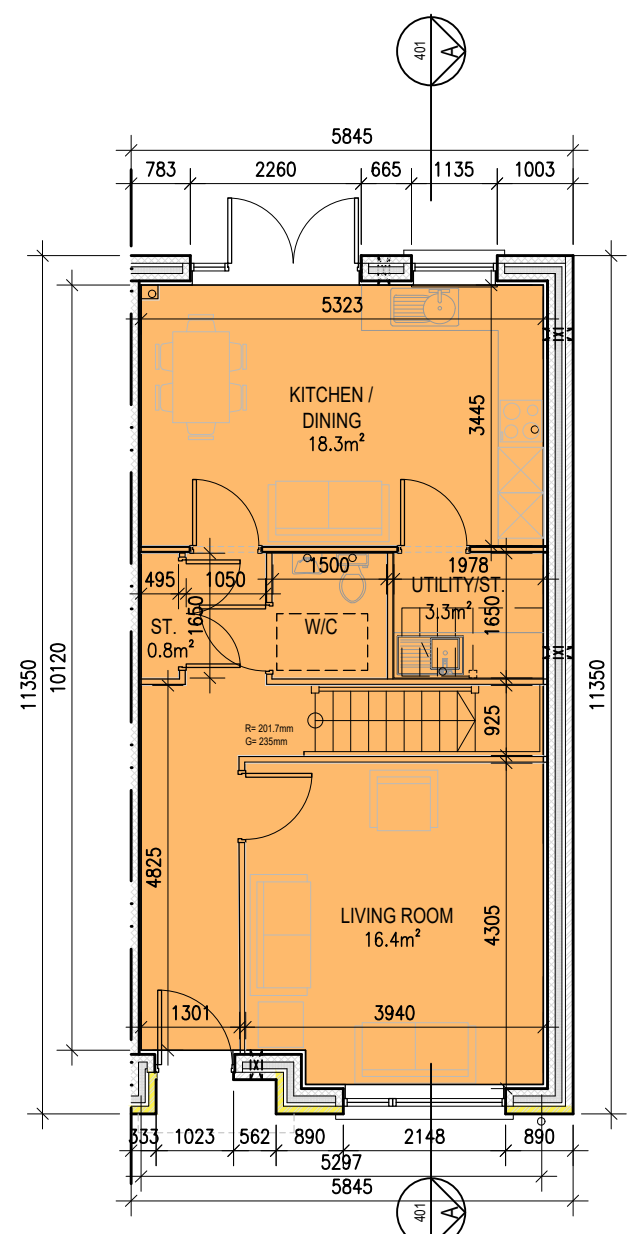
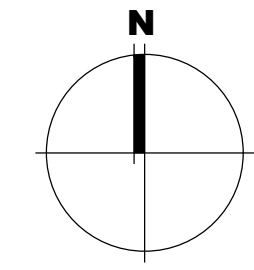

01 TYPE B1 - GROUND FLOOR PLAN
1:100@A1

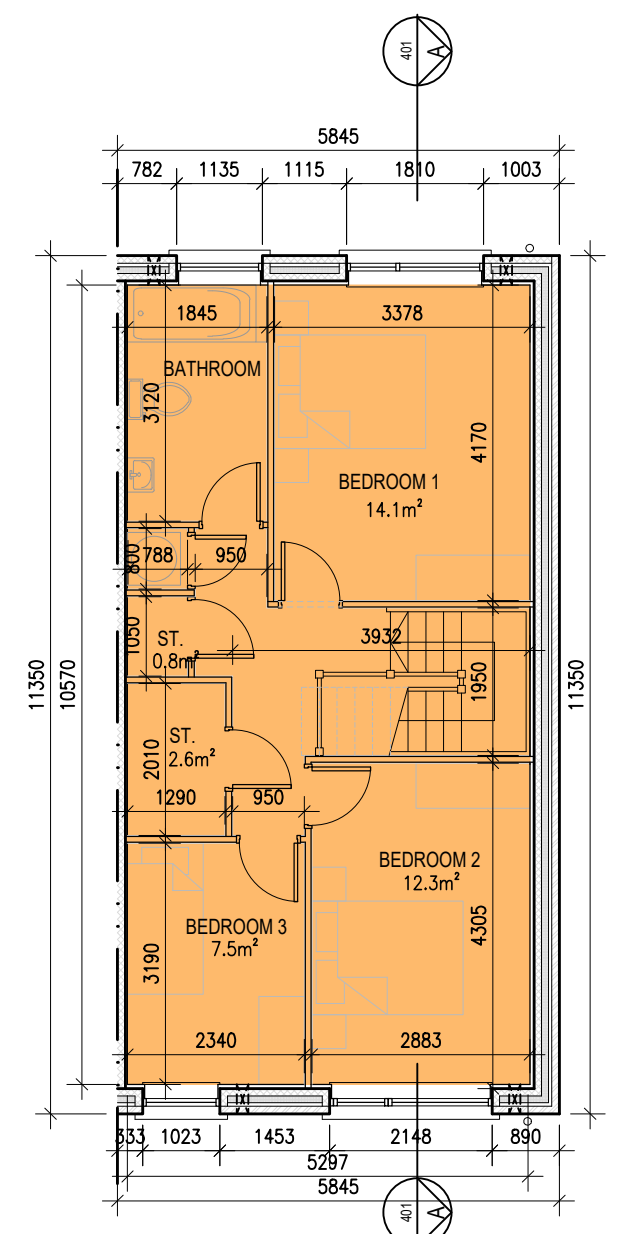

02 TYPE B1 - FIRST FLOOR PLAN
1:100@A1

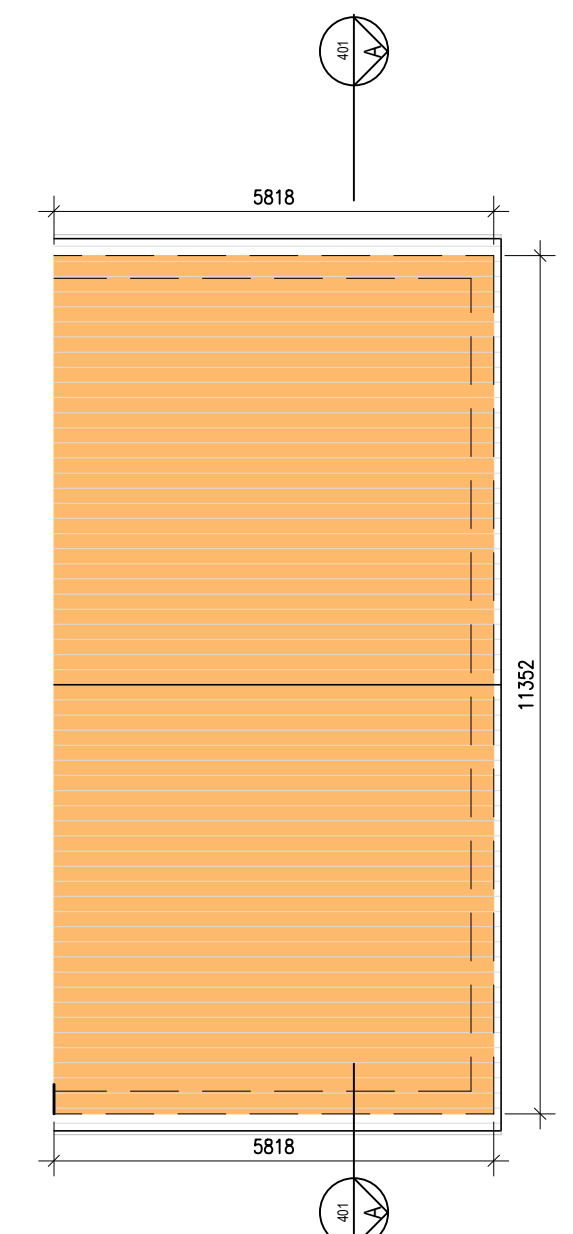

03 TYPE B - ROOF PLAN
1:100@A1

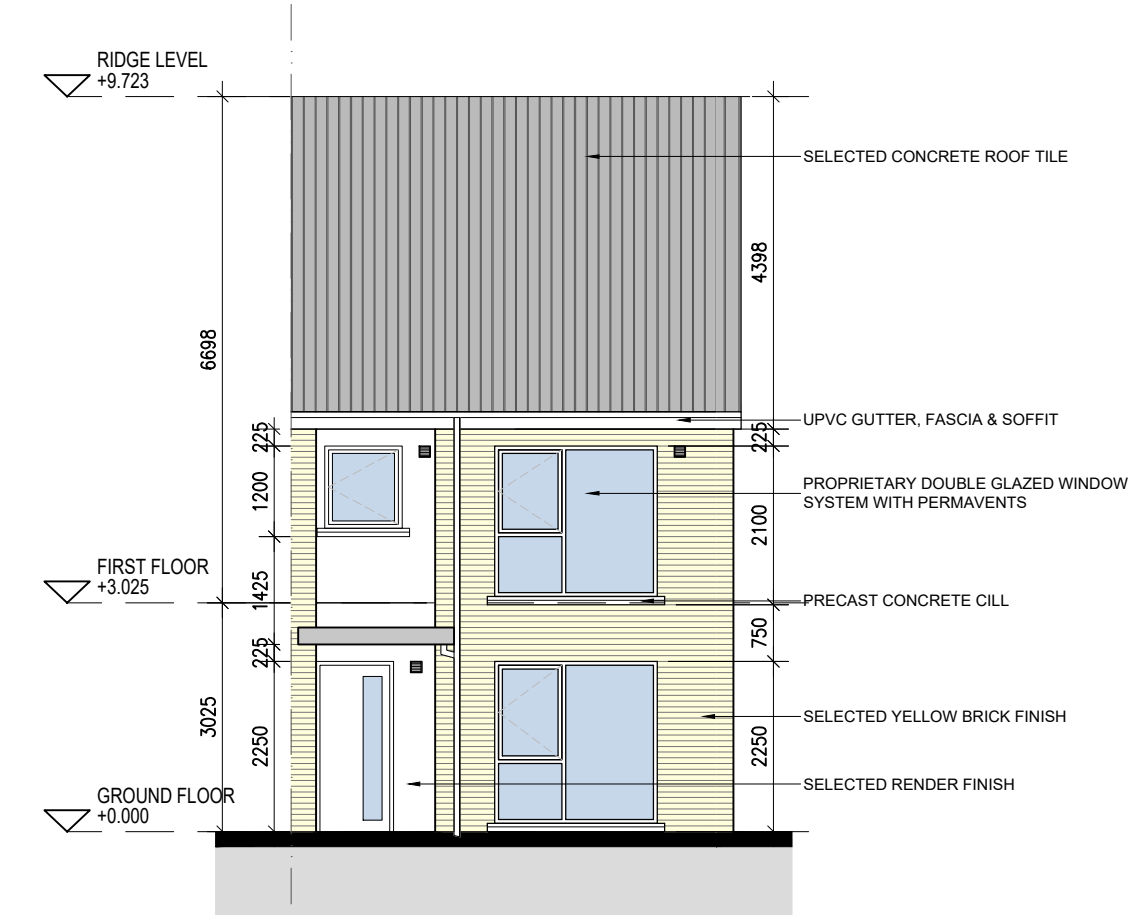

04 TYPE B1 - FRONT ELEVATION / ROWAN
1:100@A1

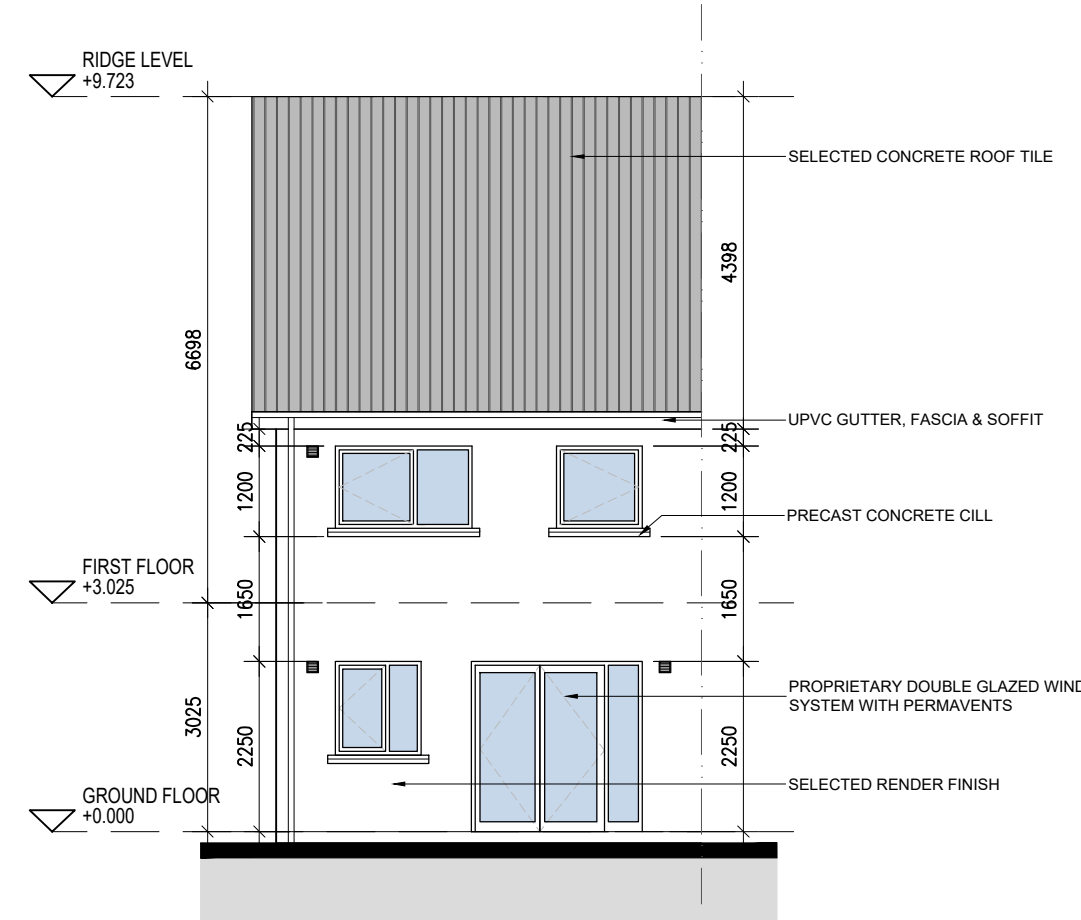

05 TYPE B1 - REAR ELEVATION
1:100@A1

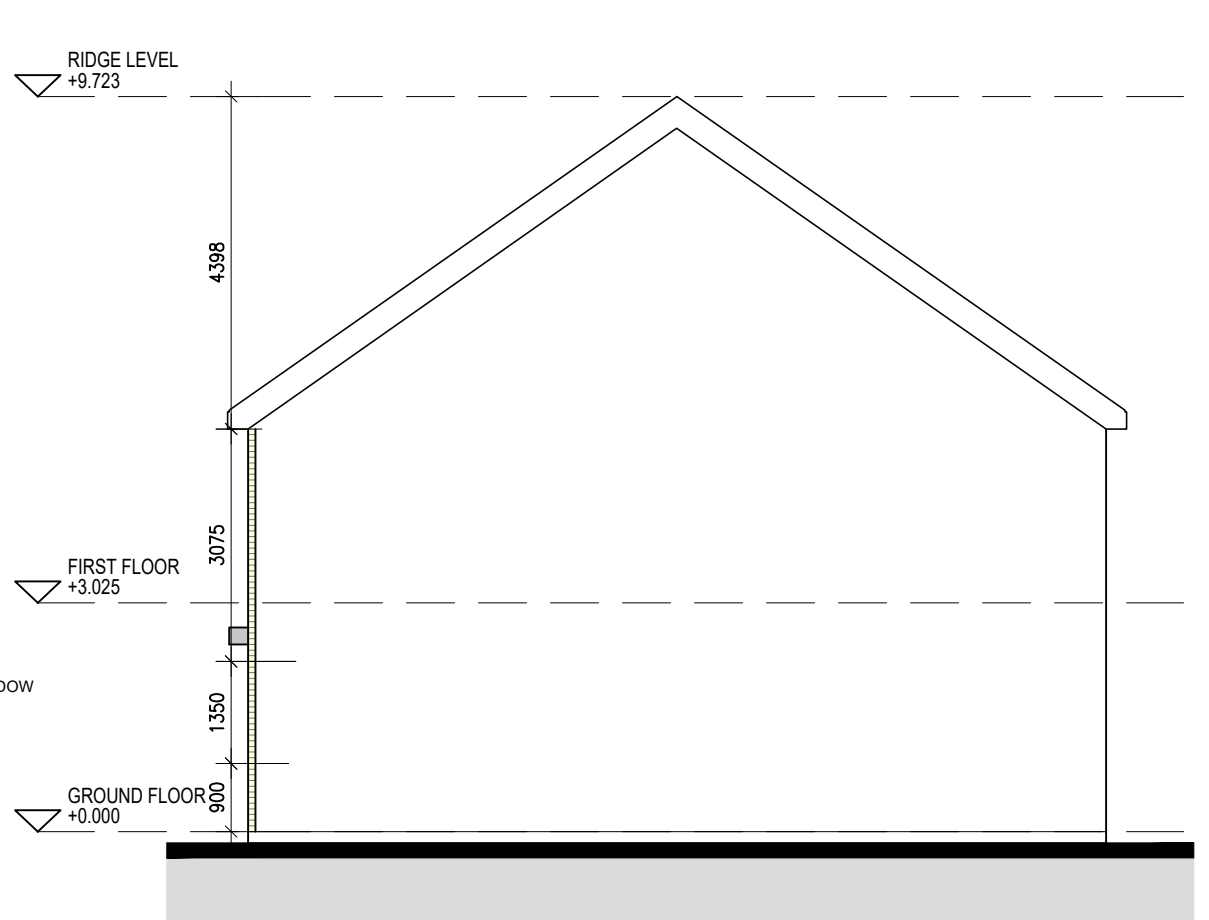

06 TYPE B1 - SIDE ELEVATION
1:100@A1

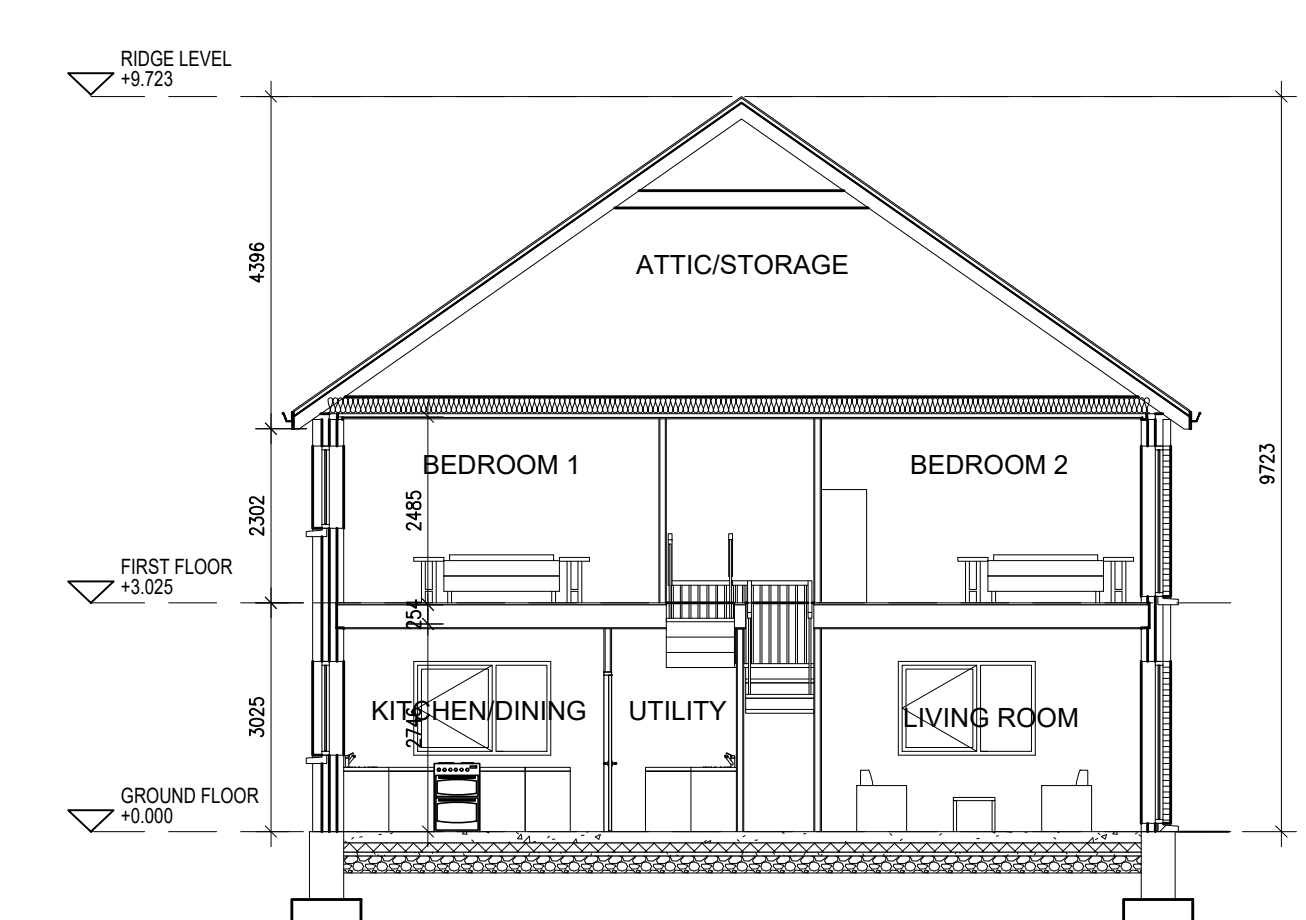

07 TYPE B1 - SECTION A-A
1:100@A1

REFER ALSO TO SITE SETTING-OUT PLANS AND ELEVATIONS

B1	3 BED - 5 PERSON HOUSE	GROUND FLOOR	FIRST FLOOR	N/A	TOTAL AREA
		55.2m ²	56.3m ²		111.5m ²

OS DATUM - MALIN HEAD

Notes	Issue Status	No.	Date	Revision	Initials
1. Copyright Reserved	Progress	01	13/11/23	Draft Issue For Discussion	ED
2. Work to figured dimensions only. Do not scale drawing	Planning Application	02	23/11/23	Part 8 Issue	ED
3. The contractor is responsible for checking all levels and dimensions on site and shall refer all discrepancies to the Architect	Fire Cert				
4. Where appropriate, for details of r.c. structure, or mechanical and electrical details, see Engineers drawings	Disability Cert				
5. Proprietary items shall be fixed in strict accordance with manufacturers instructions.	Tender				
6. Sizes of proprietary items shall be checked with manufacturer.	Construction				
7. The contractor shall be responsible for the coordination of structure, finishes and services.	As Built				
	Information Only				

Project: RESIDENTIAL DEVELOPMENT AT UPPER NANGOR ROAD, KILCARRBERY, CO. DUBLIN

Drawing Title: UNIT TYPE B1 - PLANS, ELEVATIONS & SECTION

Drawing No: 6168A-P-401

Scale: 1:100@A1 Rev: 02 Drawn: ED Date: 23/11/23

bkdarchitects
BURKE-KENNEDY DOYLE

6-7 HARPCURT TERRACE, DUBLIN 2, IRELAND
T: +353-1-6182400 F: +353-1-6767396
www.bkd.ie

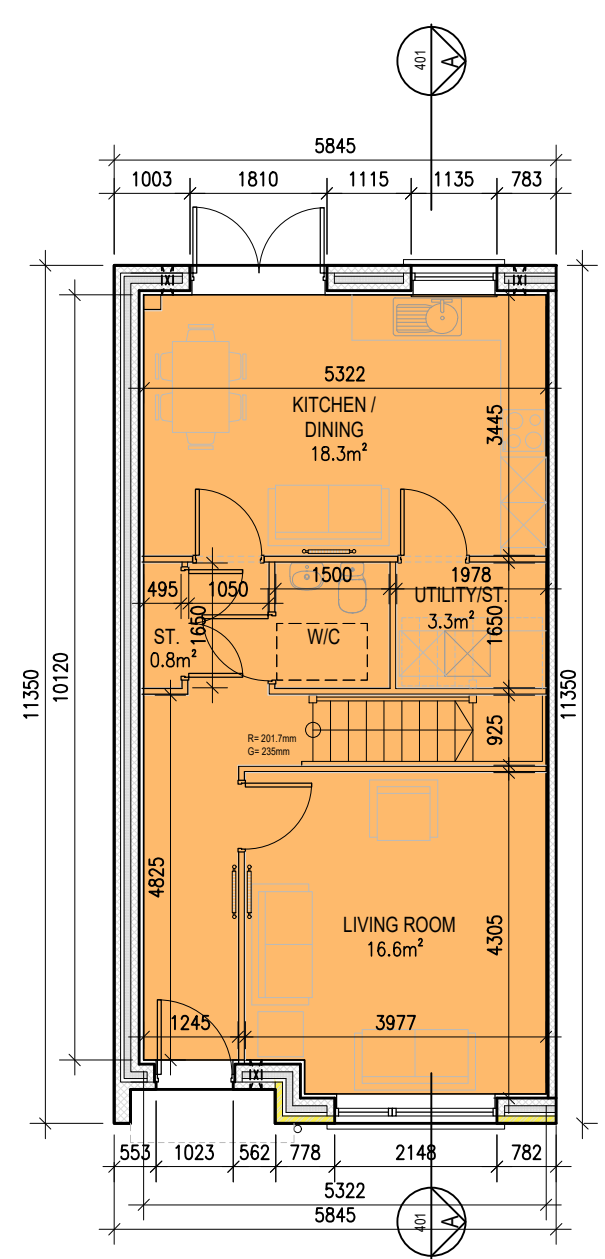

01 TYPE B2 - GROUND FLOOR PLAN
1:100@A1

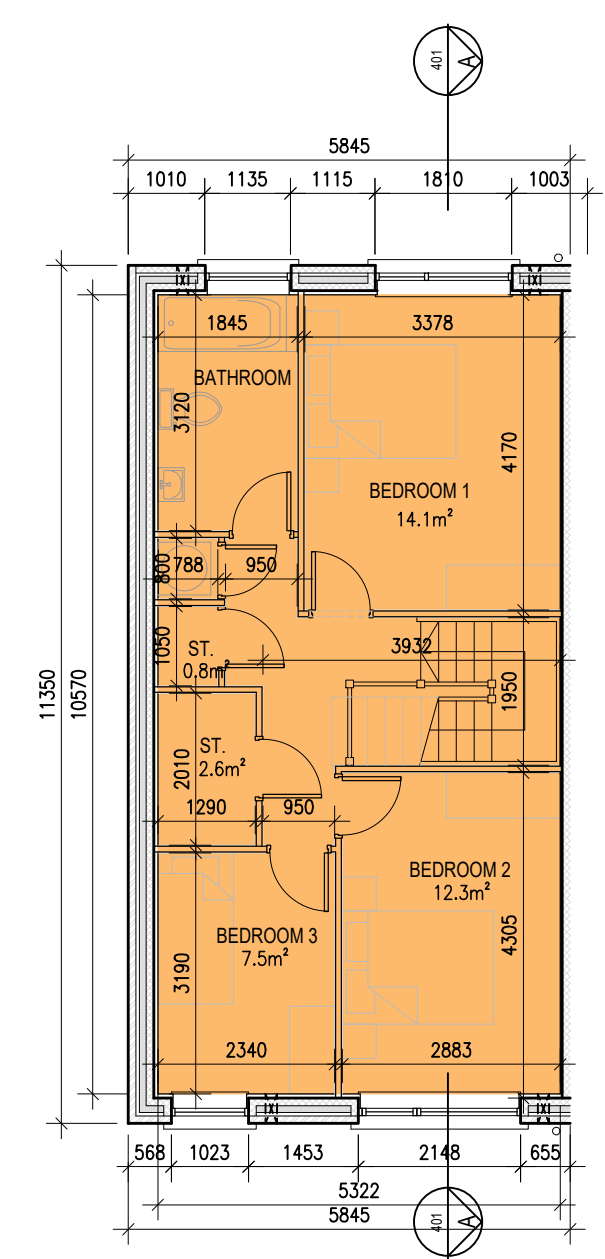

02 TYPE B2 - FIRST FLOOR PLAN
1:100@A1

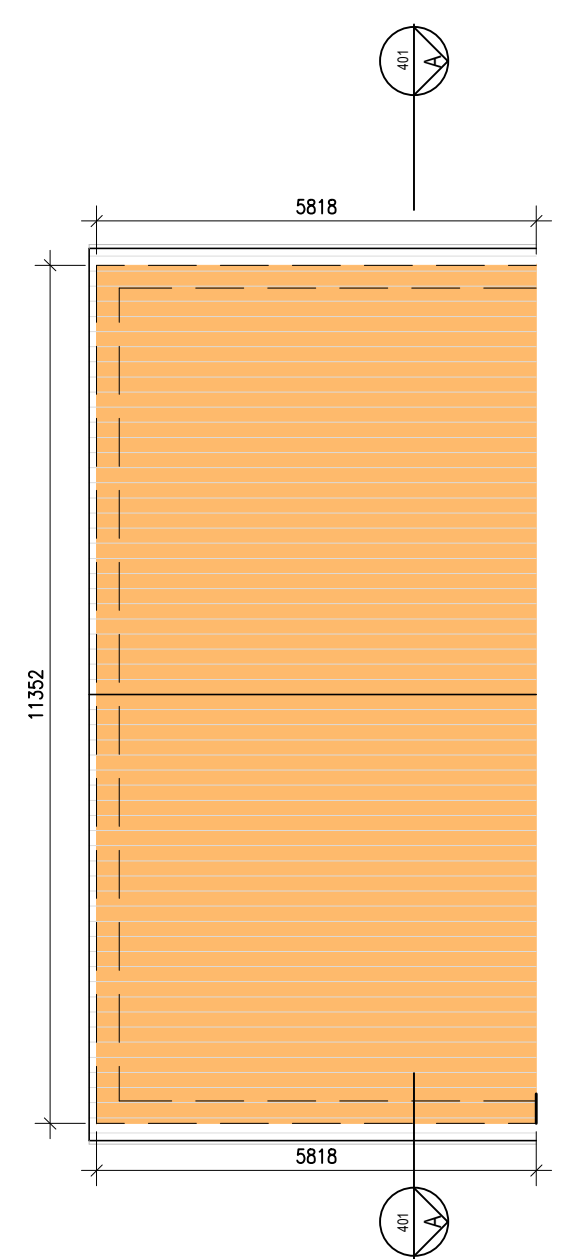

03 TYPE B - ROOF PLAN
1:100@A1

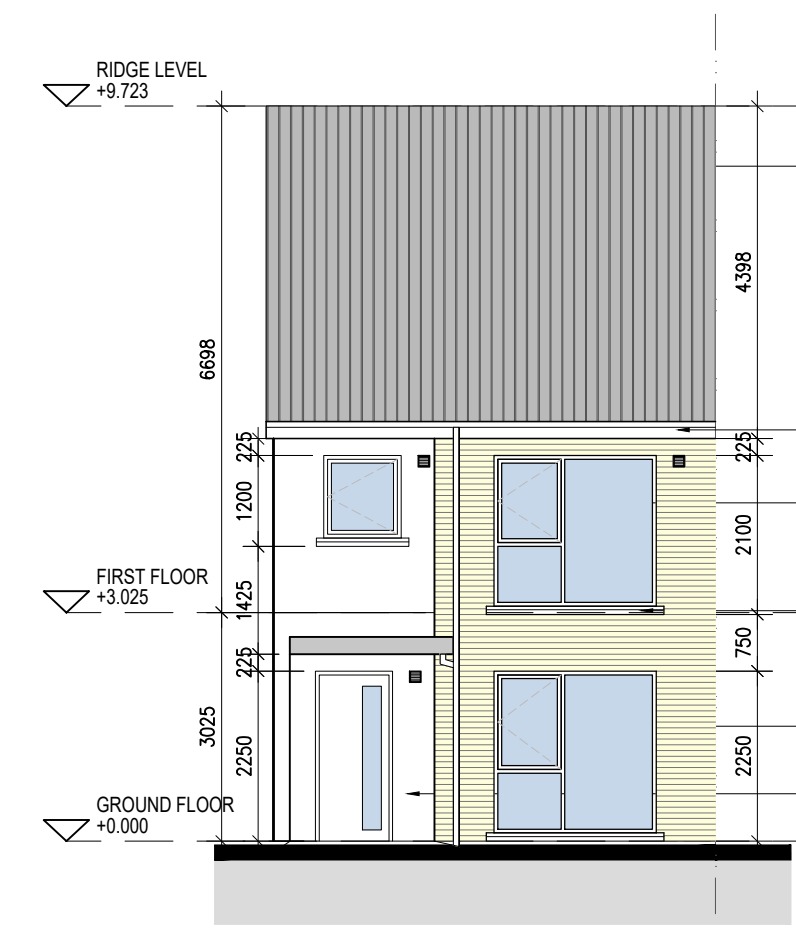

04 TYPE B2 - FRONT ELEVATION / ROWAN
1:100@A1

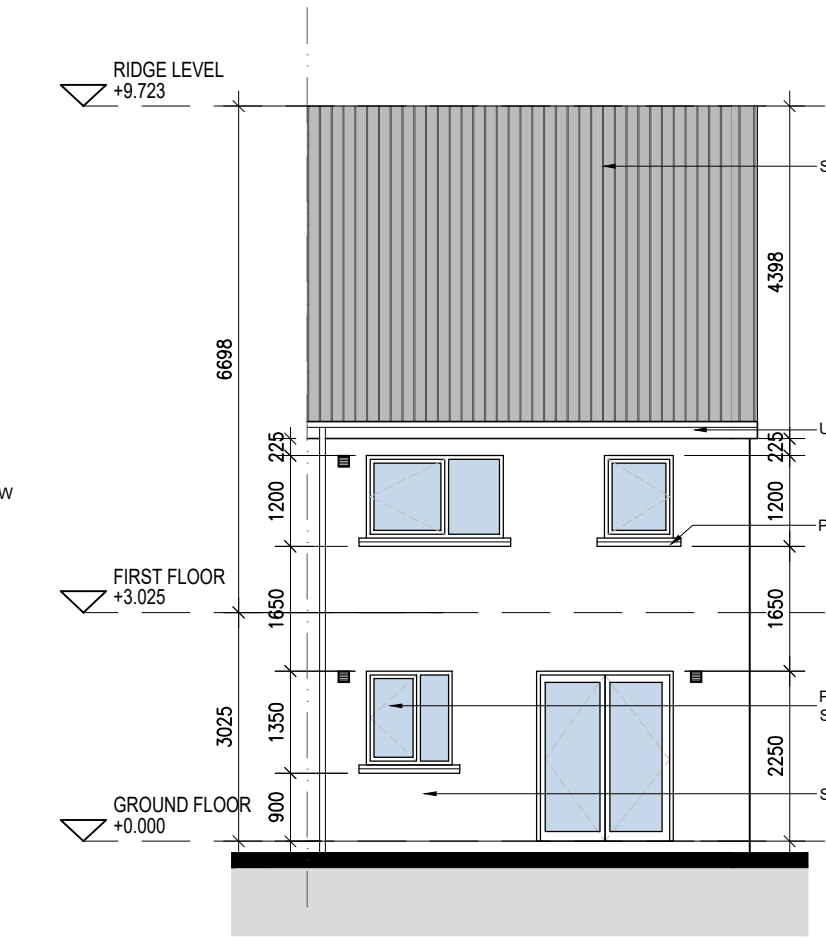

05 TYPE B2 - REAR ELEVATION
1:100@A1

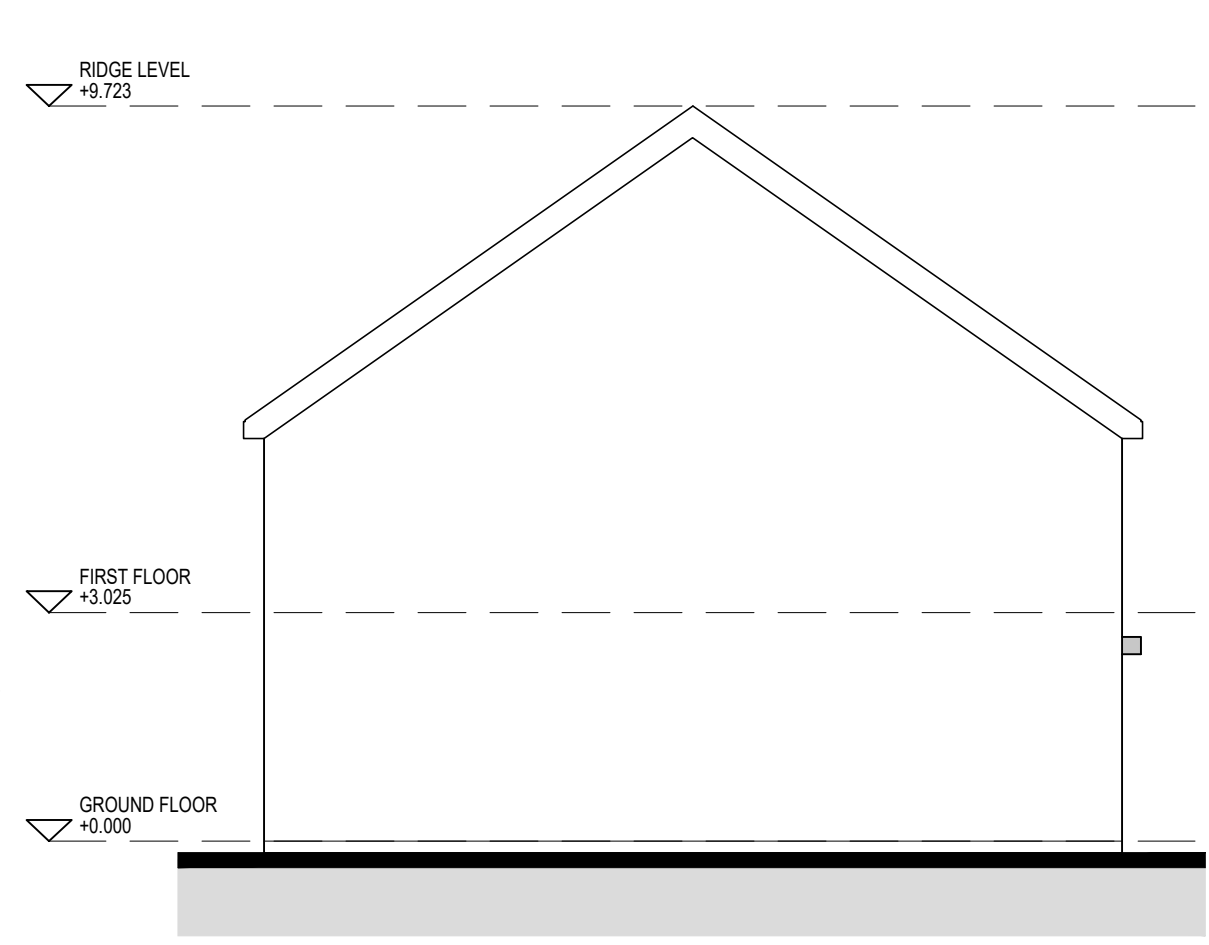

06 TYPE B2 - SIDE ELEVATION
1:100@A1

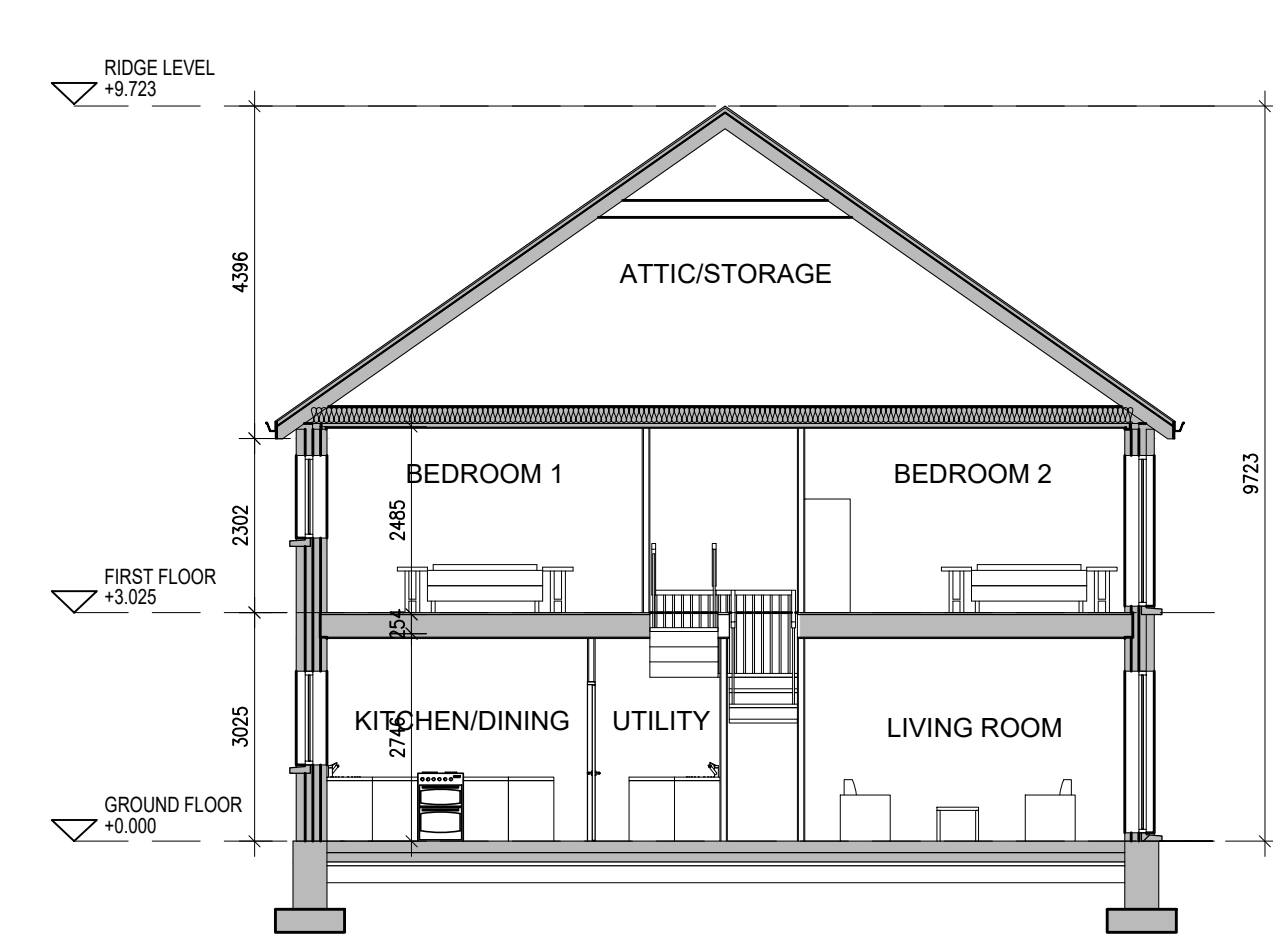

07 TYPE B2 - SECTION A-A
1:100@A1

REFER ALSO TO SITE SETTING-OUT PLANS AND ELEVATIONS

B2	3 BED - 5 PERSON HOUSE	GROUND FLOOR	FIRST FLOOR	N/A	TOTAL AREA
		55.2m ²	56.3m ²		111.5m ²

OS DATUM - MALIN HEAD

Notes	Issue Status	No.	Date	Revision	Initials
1. Copyright Reserved	Progress	01	13/11/23	Draft Issue For Discussion	ED
2. Work to figured dimensions only. Do not scale drawing	Planning Application	02	23/11/23	Part 8 Issue	ED
3. The contractor is responsible for checking all levels and dimensions on site and shall refer all discrepancies to the Architect	Fire Cert				
4. Where appropriate, for details of r.c. structure, or mechanical and electrical details, see Engineers drawings	Disability Cert				
5. Proprietary items shall be fixed in strict accordance with manufacturers instructions.	Tender				
6. Sizes of proprietary items shall be checked with manufacturer.	Construction				
7. The contractor shall be responsible for the coordination of structure, finishes and services.	As Built				
	Information Only				

Project: RESIDENTIAL DEVELOPMENT AT UPPER NANGOR ROAD, KILCABERY, CO. DUBLIN

Drawing Title: UNIT TYPE B2 - PLANS, ELEVATIONS & SECTION

Drawing No: 6168A-P-402

Scale: 1:100@A1 Rev: 02 Drawn: ED Date: 23/11/23

bkdarchitects
BURKE-KENNEDY DOYLE

6-7 HARPCOURT TERRACE, DUBLIN 2, IRELAND
T: +353-1-6182400 F: +353-1-6767396
www.bkd.ie

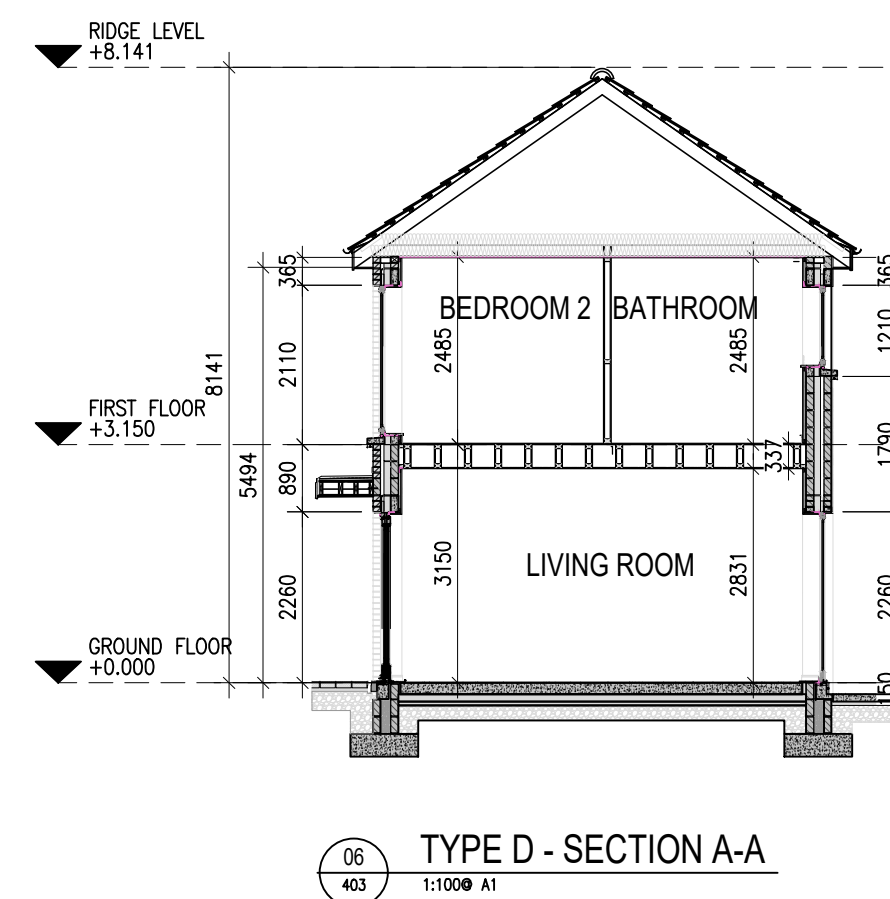
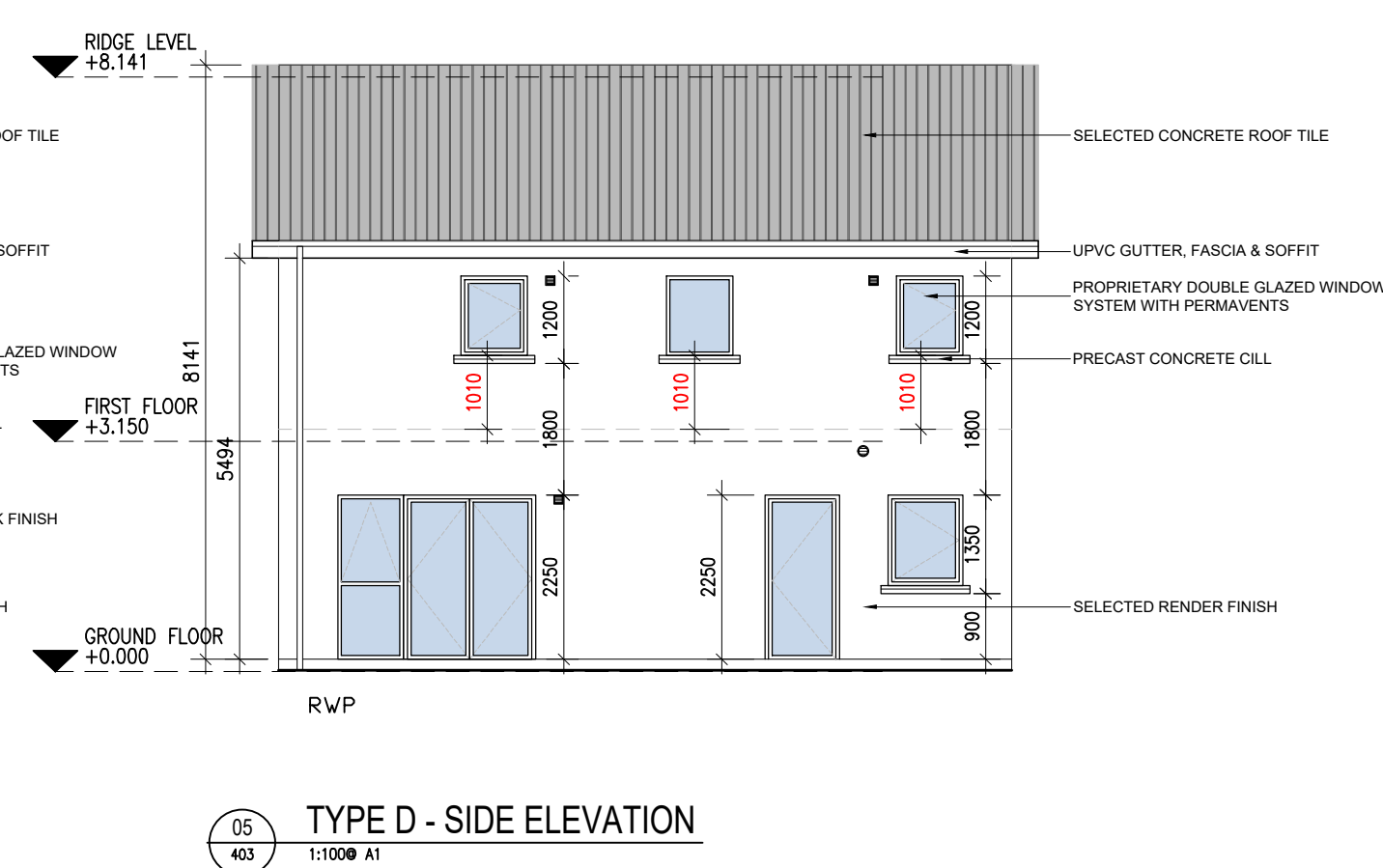
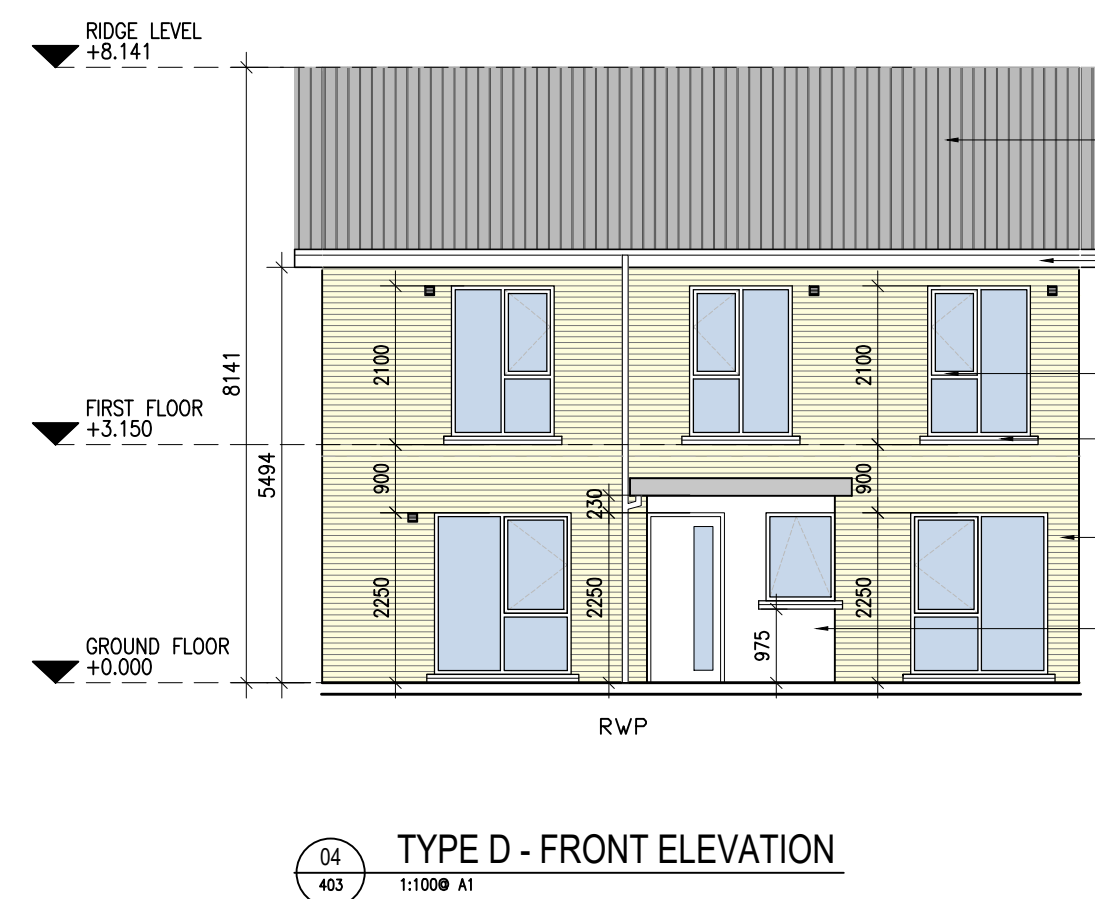
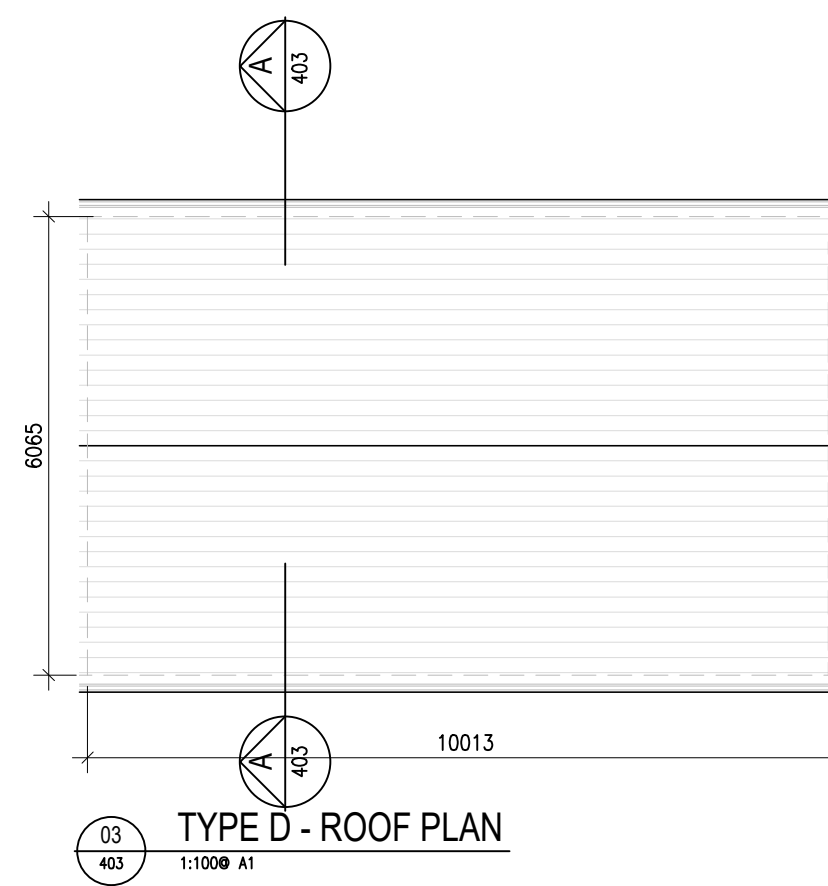
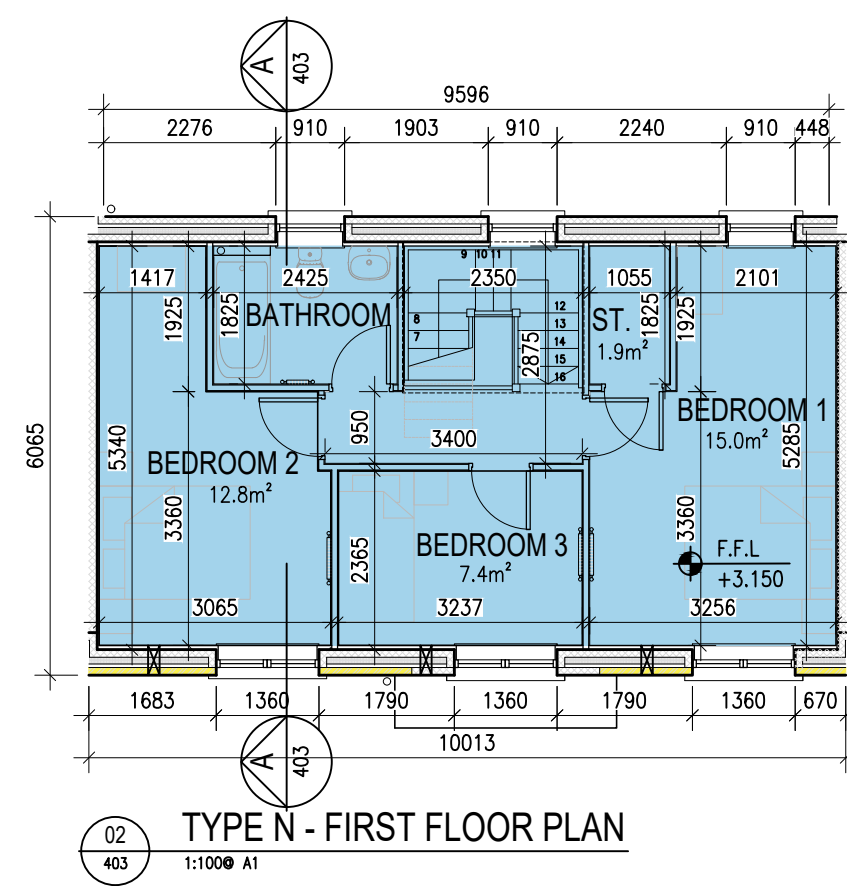
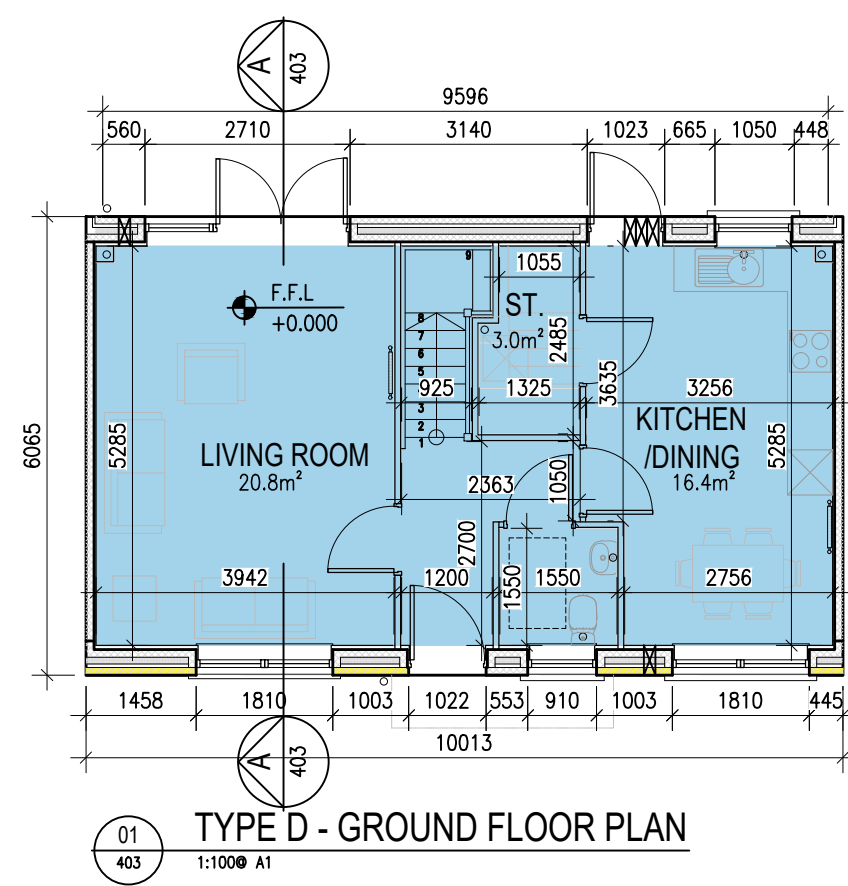

REFER ALSO TO SITE SETTING-OUT PLANS AND ELEVATIONS

D	3 BED - 5 PERSON HOUSE	GROUND FLOOR	FIRST FLOOR	N/A	TOTAL AREA
		51.5m ²	51.5m ²		103m ²

OS DATUM - MALIN HEAD

Notes	Issue Status
1. Copyright Reserved	Progress
2. Work to figure dimensions only. Do not scale drawing	Planning Application
3. The contractor is responsible for checking all levels and dimensions on site and shall refer all discrepancies to the Architect	Fire Cert
4. Where appropriate, for details of r.c. structure, or mechanical and electrical details, see Engineers drawings	Disability Cert
5. Proprietary items shall be fixed in strict accordance with manufacturers instructions.	Tender
6. Sizes of proprietary items shall be checked with manufacturer.	Construction
7. The contractor shall be responsible for the coordination of structure, finishes and services.	As Built
	Information Only

No.	Date	Revision	Initials
01	13/11/23	Draft Issue For Discussion	ED
02	23/11/23	Part 8 Issue	ED

Project: RESIDENTIAL DEVELOPMENT AT UPPER NANGOR ROAD, KILCABERY, CO. DUBLIN

Drawing Title: UNIT TYPE D - PLANS, ELEVATIONS & SECTION

Drawing No: 6168A-P-403

Scale: 1:100@A1 Rev: 02 Drawn: ED Date: 23/11/23

bkdarchitects
BURKE-KENNEDY DOYLE

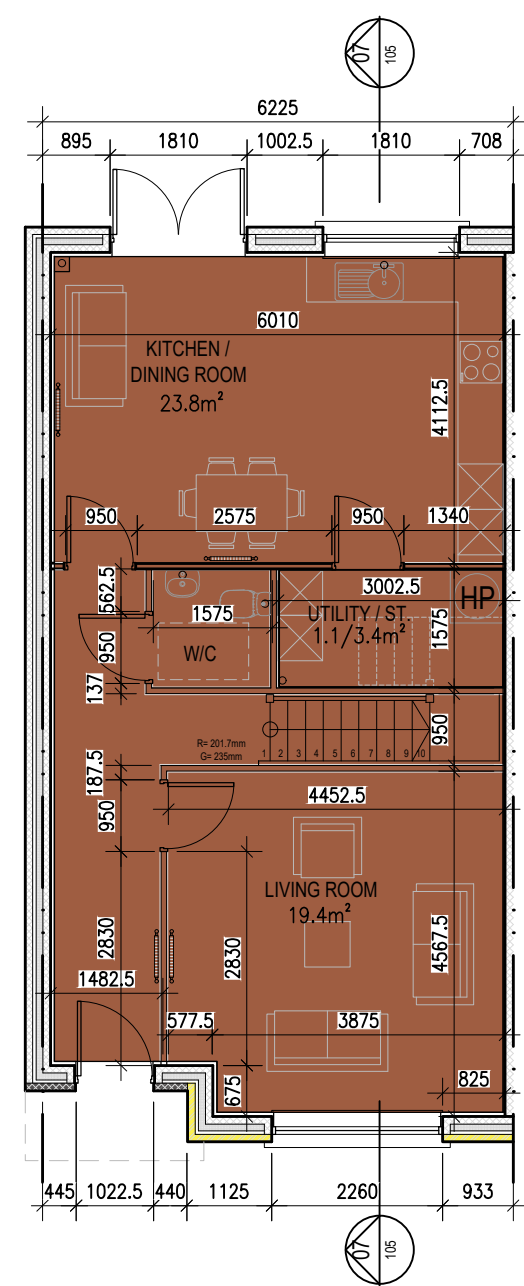

01 TYPE E2 - GROUND FLOOR PLAN
1:100@A1

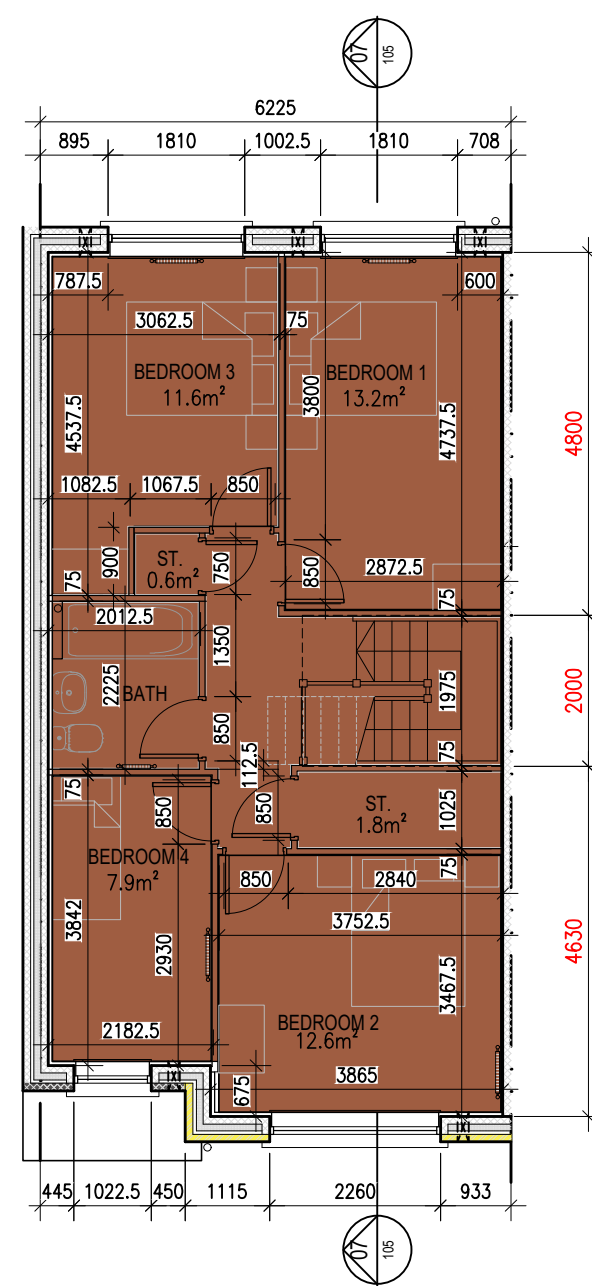

02 TYPE E2 - FIRST FLOOR PLAN
1:100@A1

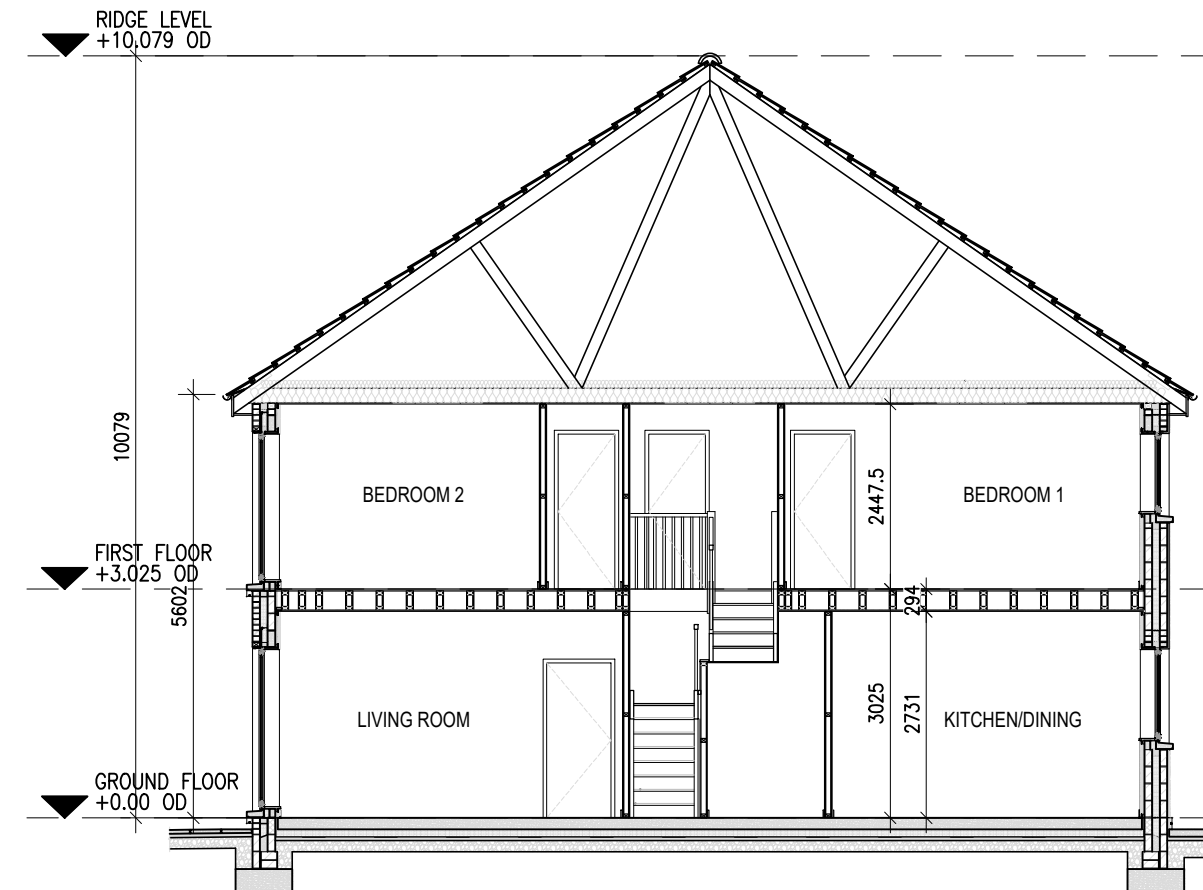

03 TYPE E2 - SECTION A-A
1:100@A1

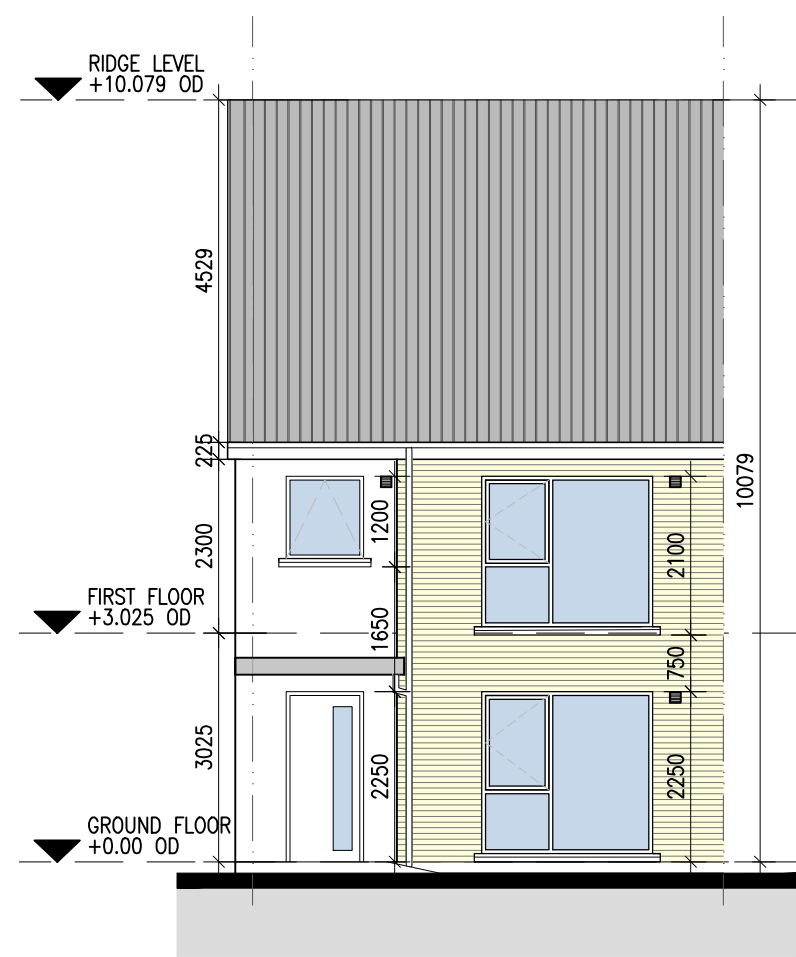

04 TYPE E2 - FRONT ELEVATION
1:100@A1

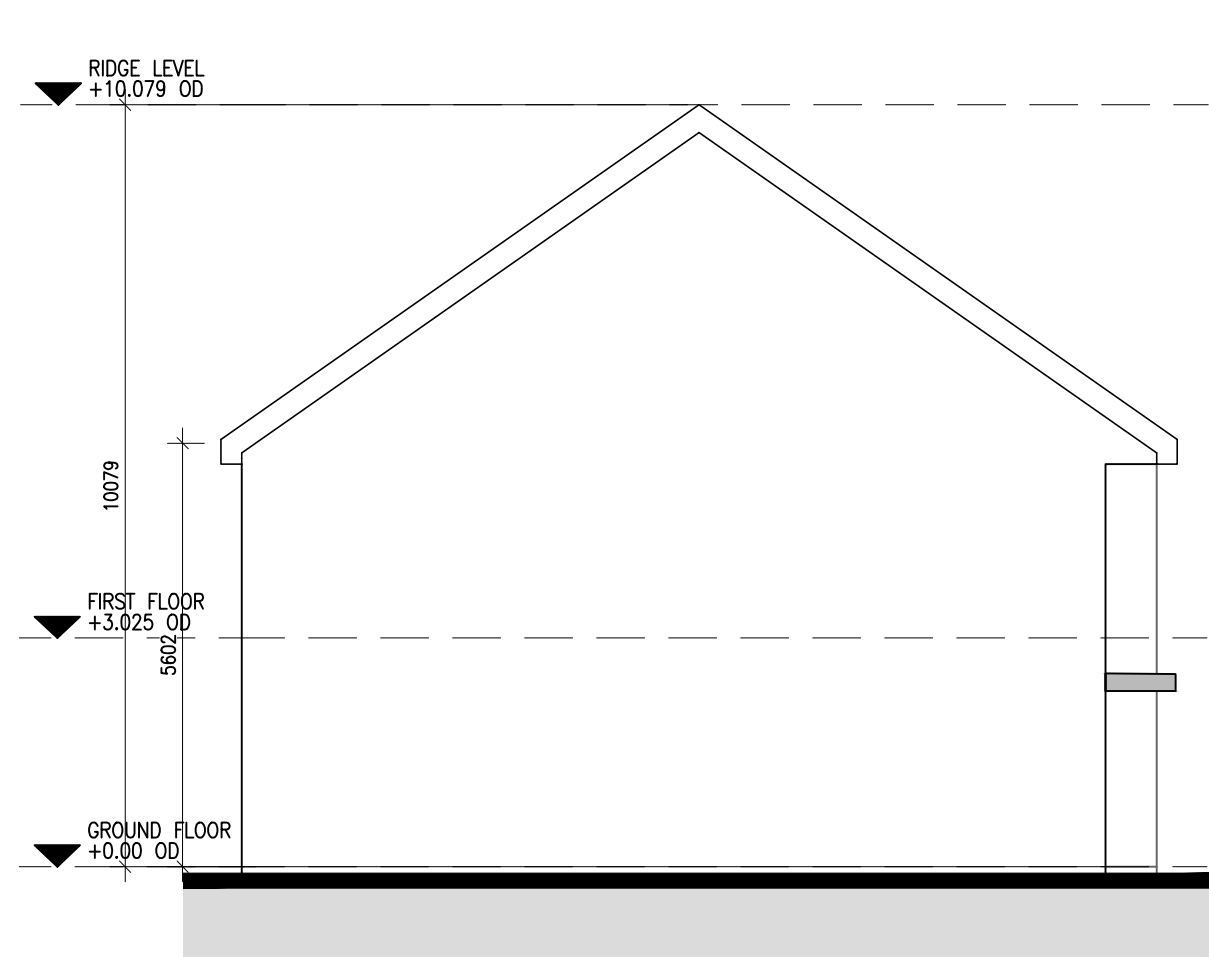

05 TYPE E2 - SIDE ELEVATION
1:100@A1

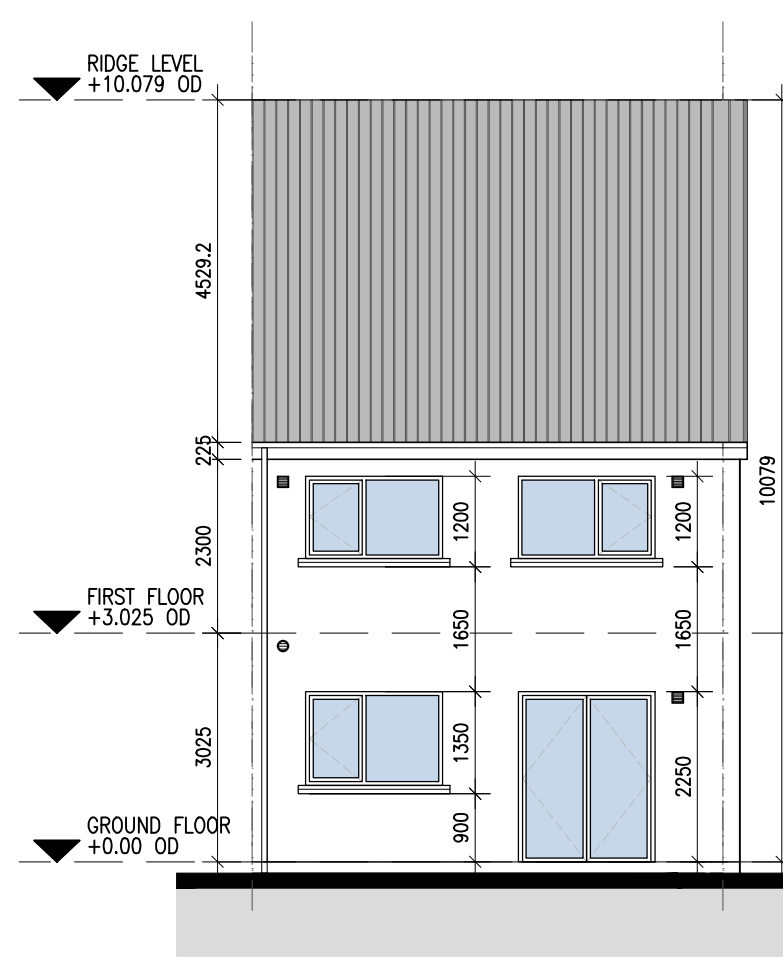

06 TYPE E2 - REAR ELEVATION
1:100@A1

REFER ALSO TO SITE SETTING-OUT PLANS AND ELEVATIONS

E2	4 BED - 7 PERSON HOUSE SOCIAL	GROUND FLOOR	FIRST FLOOR	N/A	TOTAL AREA
		65.7m ²	65.6m ²		131.3m ²

REFER TO SITE PLAN FOR LEVELS

- Notes
- Copyright Reserved
 - Work to figured dimensions only. Do not scale drawing.
 - The contractor is responsible for checking all levels and dimensions on site and shall refer all discrepancies to the Architect.
 - Where appropriate, for details of r.c. structure, or mechanical and electrical details, see Engineers drawings.
 - Proprietary items shall be fixed in strict accordance with manufacturers instructions.
 - Sizes of proprietary items shall be checked with manufacturer.
 - The contractor shall be responsible for the coordination of structure, finishes and services.

Issue Status	Progress
Planning Application	■
Fire Cert	
Disability Cert	
Tender	
Construction	
As Built	
Information Only	

No.	Date	Revision	Initials
01	13/11/23	Draft Issue For Discussion	ED
02	23/11/23	Plan 8 Issue	ED

Project	RESIDENTIAL DEVELOPMENT AT UPPER NANGOR ROAD, KILCARRBERY, CO. DUBLIN
Drawing Title	HOUSE TYPE E2_PLANS, ELEVATIONS & SECTION
Drawing No	6168A-P-404
Scale	1:100@A1
Rev	02
Drawn	ED
Date	23/11/23

6-7 HARDCOURT TERRACE, DUBLIN 2, IRELAND
 1 353 1 816 2400 1 353 1 676 7365
 architecture@bkd.ie
 www.bkd.ie

bkdarchitects
 BURKE-KENNEDY DOYLE

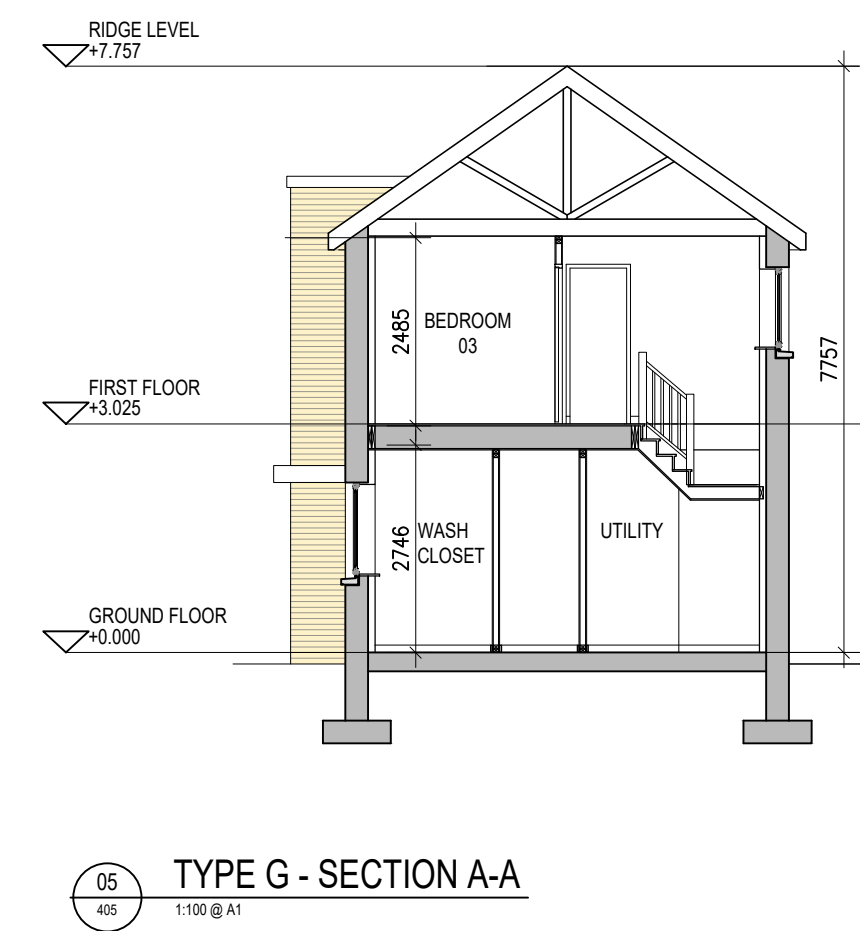
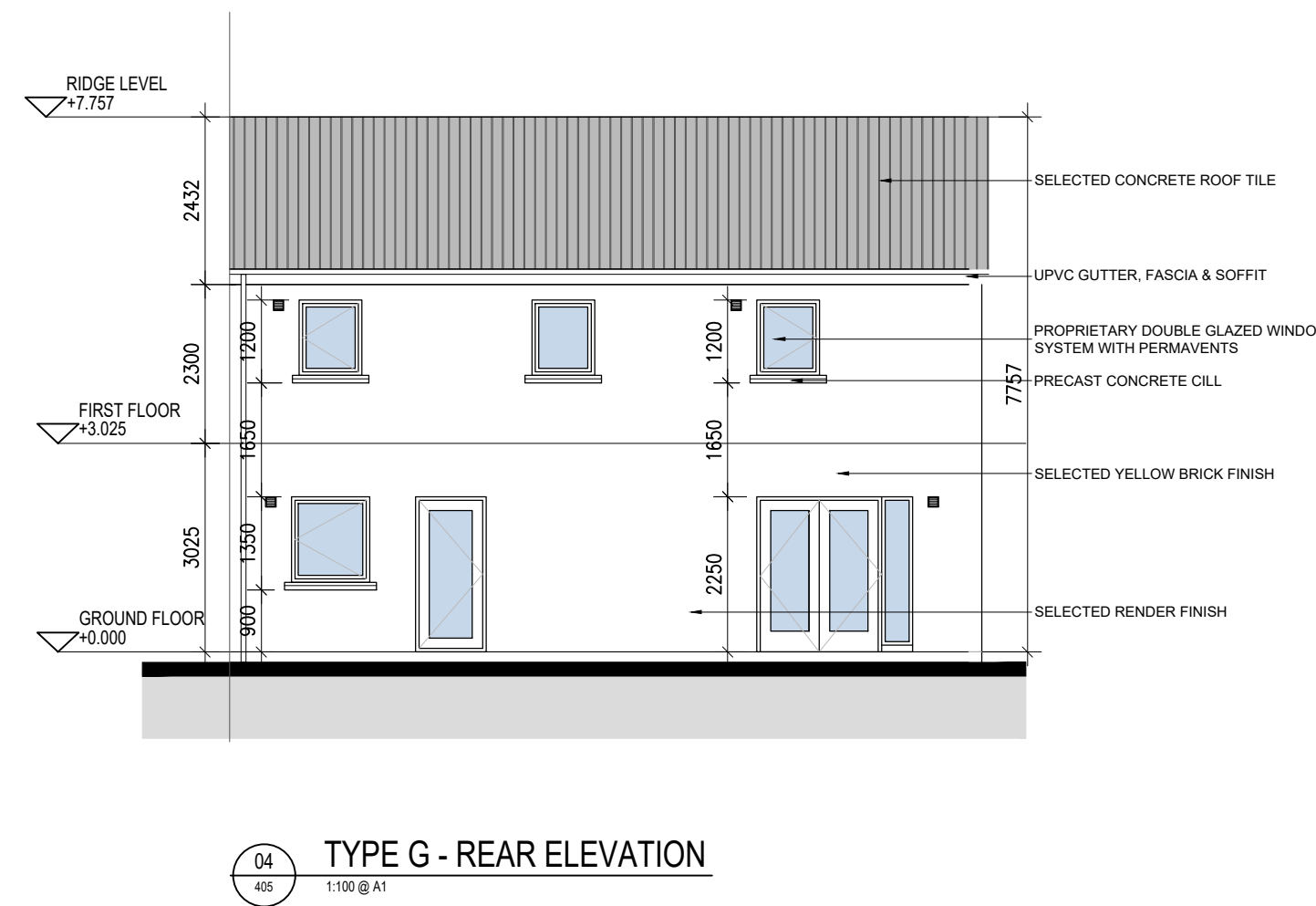
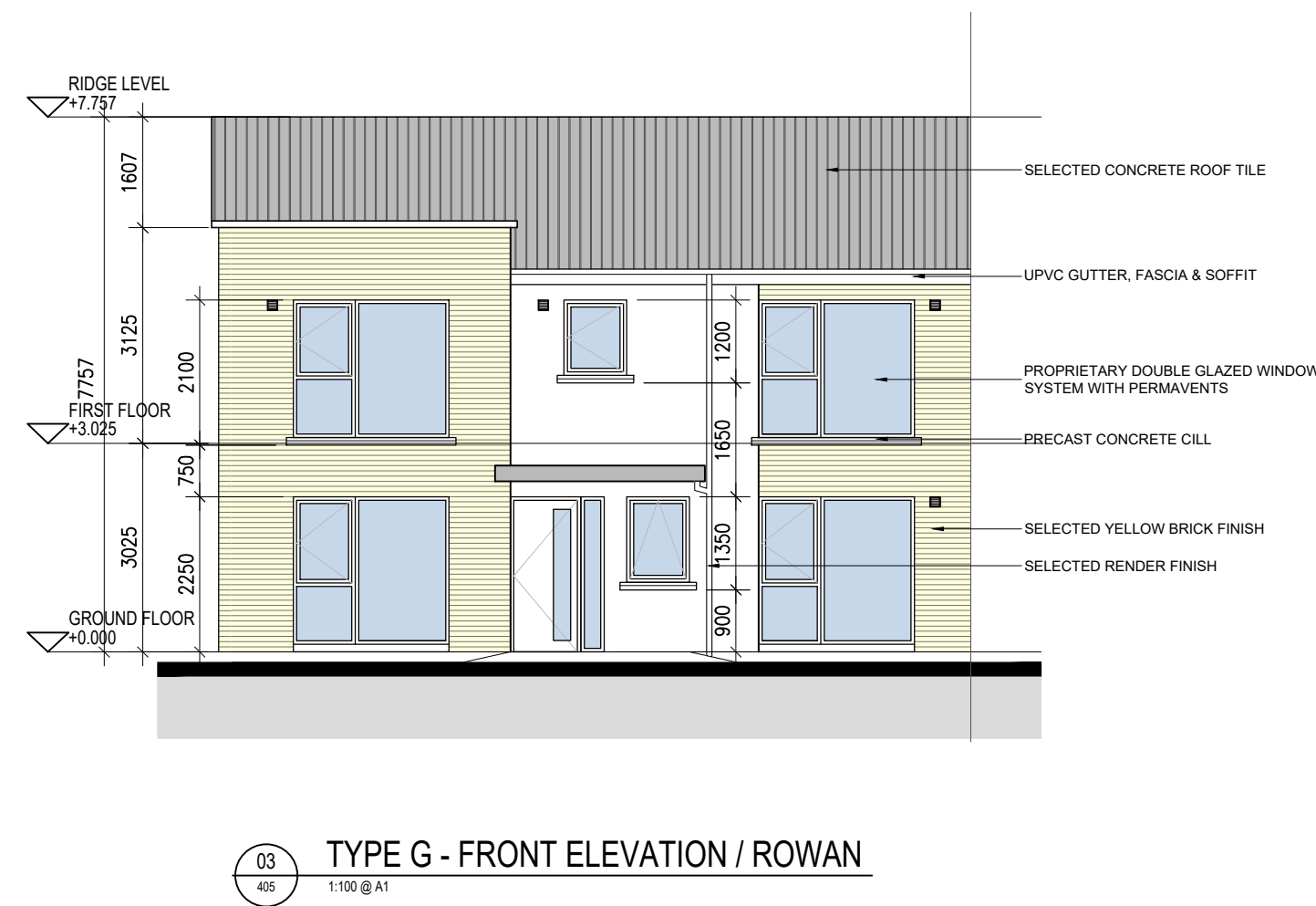
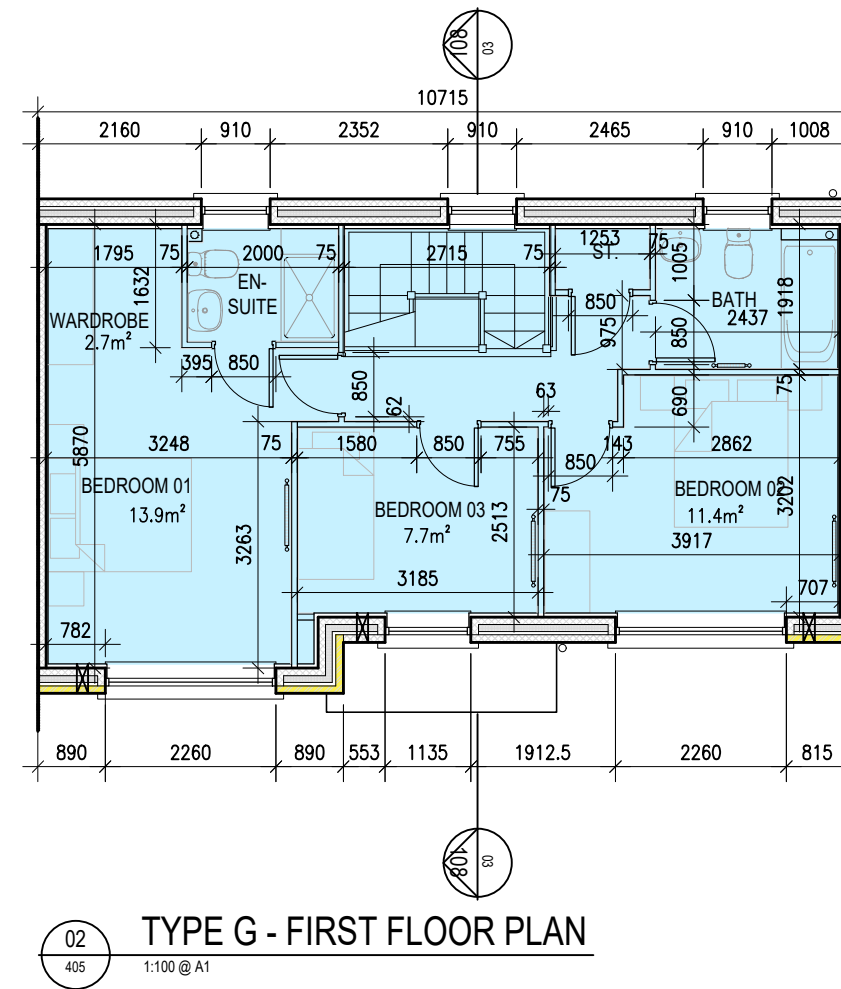
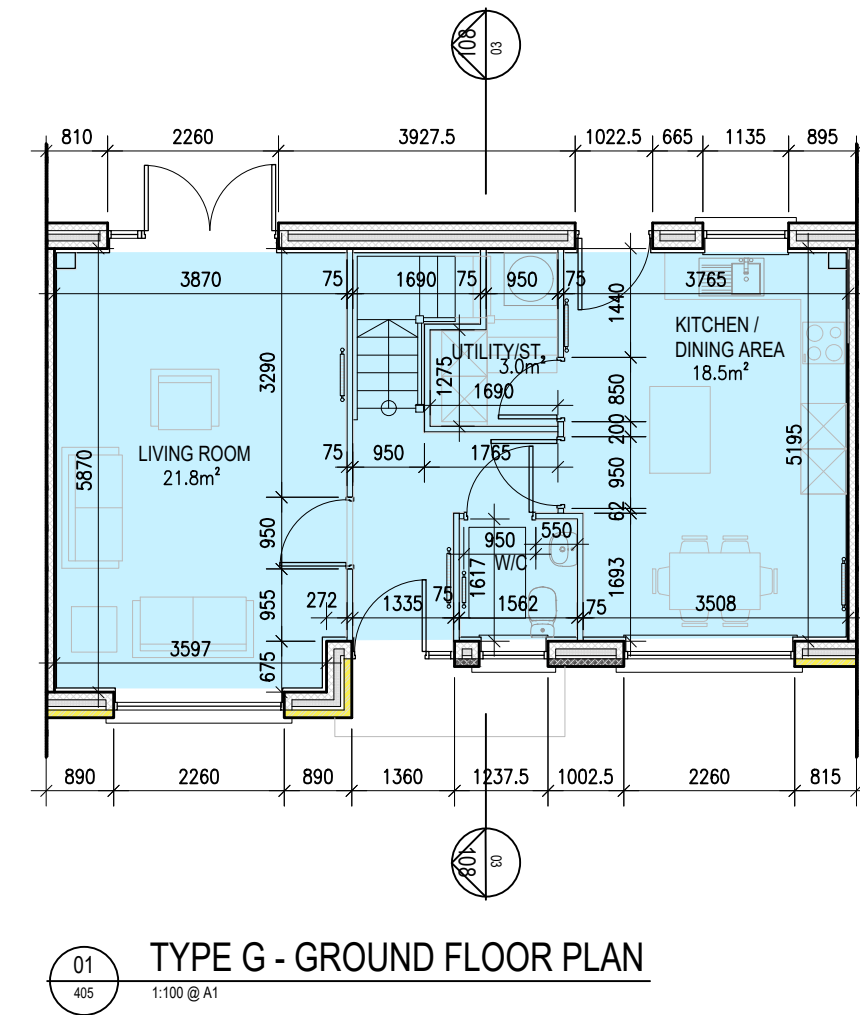
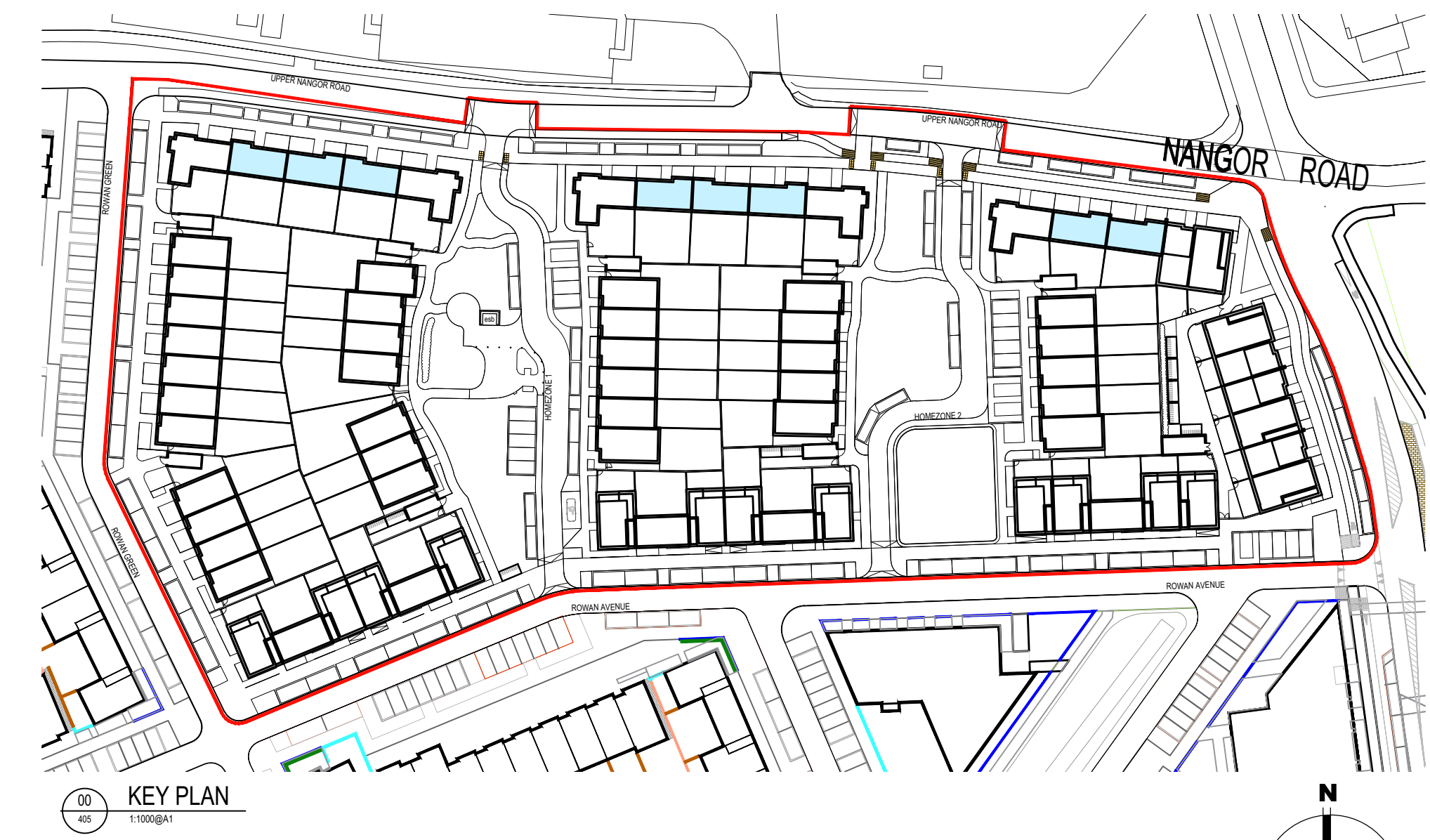

REFER ALSO TO SITE SETTING-OUT PLANS AND ELEVATIONS

G	3 BED - 5 PERSON HOUSE	GROUND FLOOR	FIRST FLOOR	N/A	TOTAL AREA
		55.4m ²	55.4m ²		110.8m ²

REFER TO SITE PLAN FOR LEVELS

Notes	Issue Status	No.	Date	Revision	Initials
1. Copyright Reserved	Progress	01	13/11/23	Draft Issue For Discussion	ED
2. Work to agreed dimensions only. Do not scale drawing.	Planning Application	02	23/11/23	Part 8 Issue	ED
3. The contractor is responsible for checking all levels and dimensions on site and shall refer all discrepancies to the Architect	Fire Cert				
4. Where appropriate, for details of r.c. structure, or mechanical and electrical details, see Engineers drawings	Disability Cert				
5. Proprietary items shall be fixed in strict accordance with manufacturers instructions.	Tender				
6. Sizes of proprietary items shall be checked with manufacturer.	Construction				
7. The contractor shall be responsible for the coordination of structure, finishes and services.	As Built				
	Information Only				

Project: RESIDENTIAL DEVELOPMENT AT UPPER NANGOR ROAD, KILCAREBRY, CO. DUBLIN

Drawing Title: HOUSE TYPE G_3 Bed_PLANS, ELEVATIONS & SECTION

Drawing No: 6168A-P-405

Scale: 1:100@A1 Rev: 02 Drawn: ED Date: 23/11/23

bkdarchitects
BURKE-KENNEDY DOYLE

6-7 HARDCOURT TERRACE, DUBLIN 2, IRELAND
t +353-1-618 2400 f +353-1-676 7396
www.bkd.ie

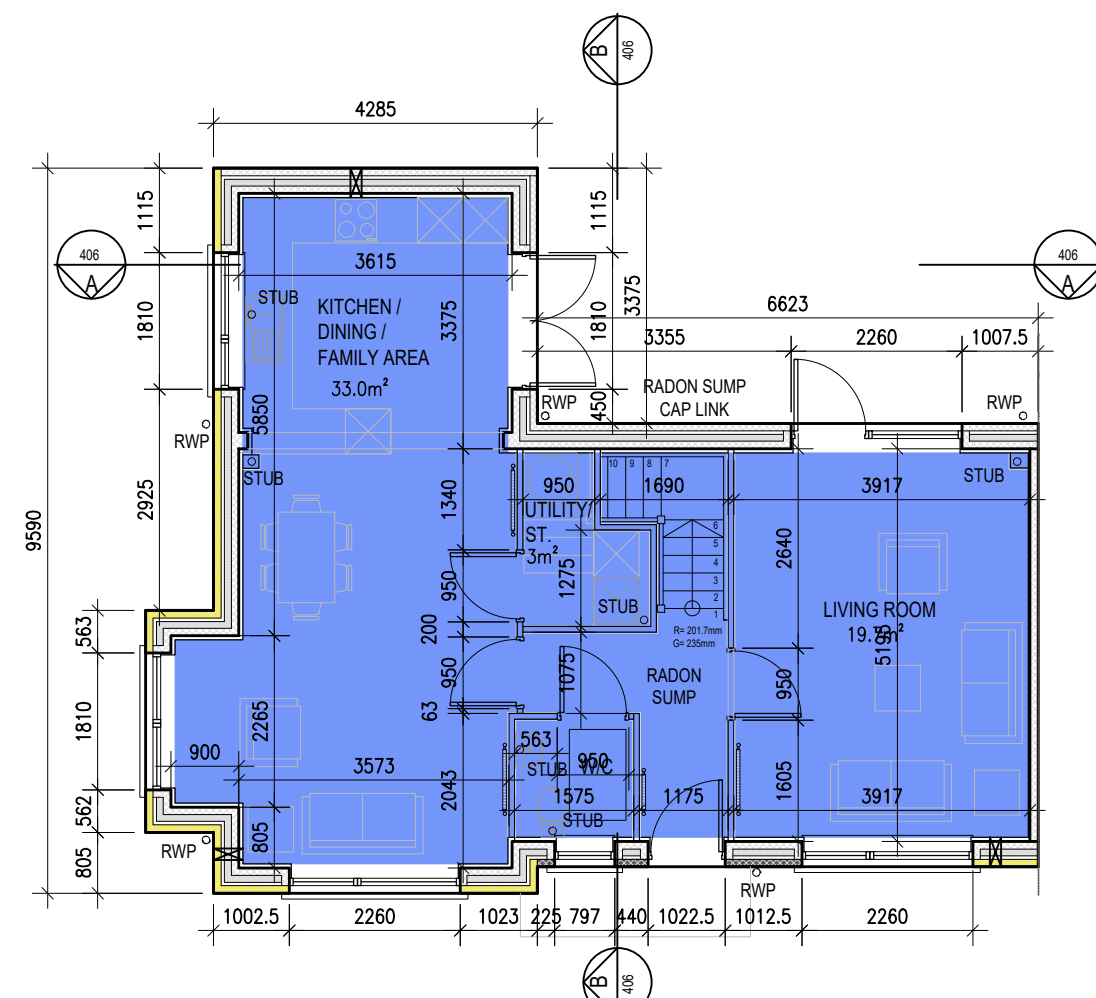

01 TYPE J - GROUND FLOOR PLAN
1:100@A1

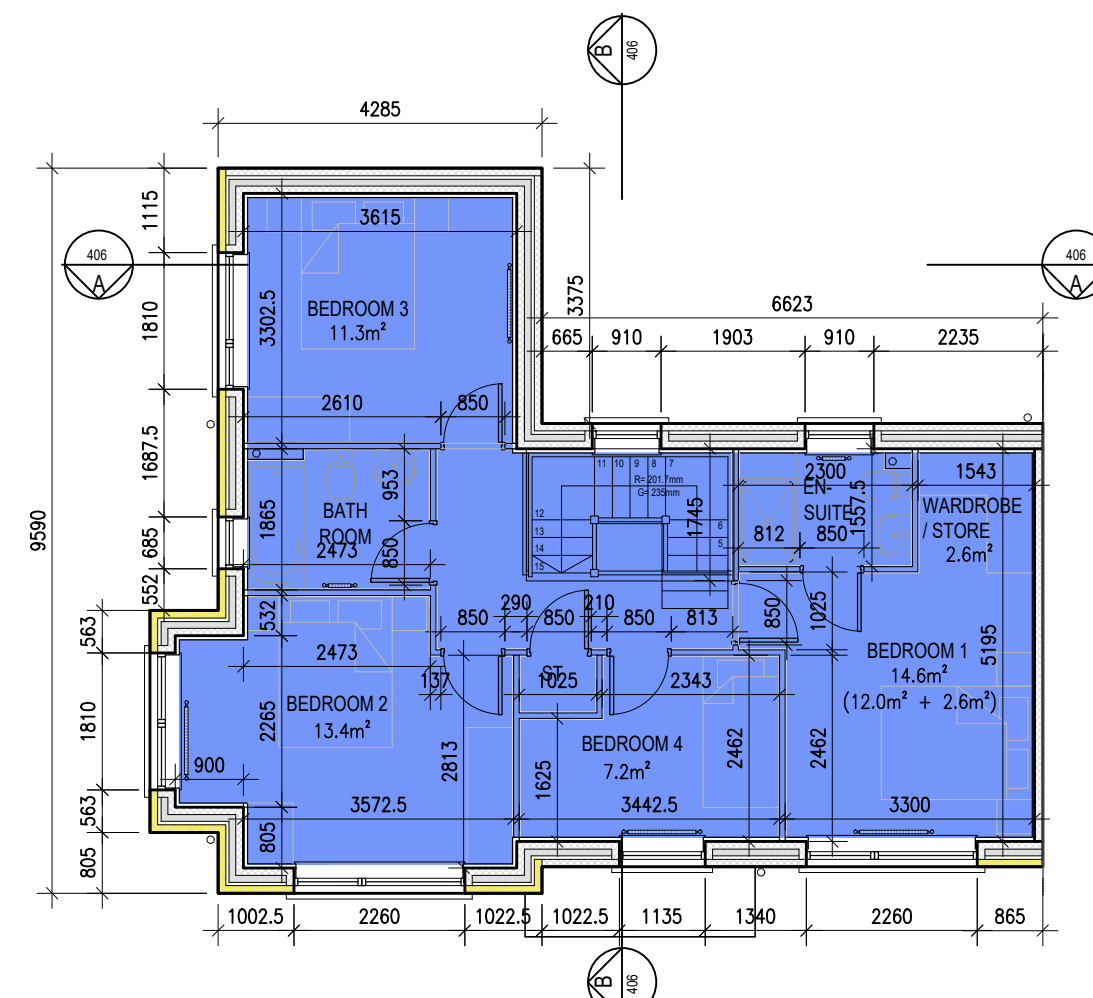

02 TYPE J - FIRST FLOOR PLAN
1:100@A1



00 KEY PLAN
1:100@A1



03 TYPE J - FRONT ELEVATION / ROWAN
1:100@A1

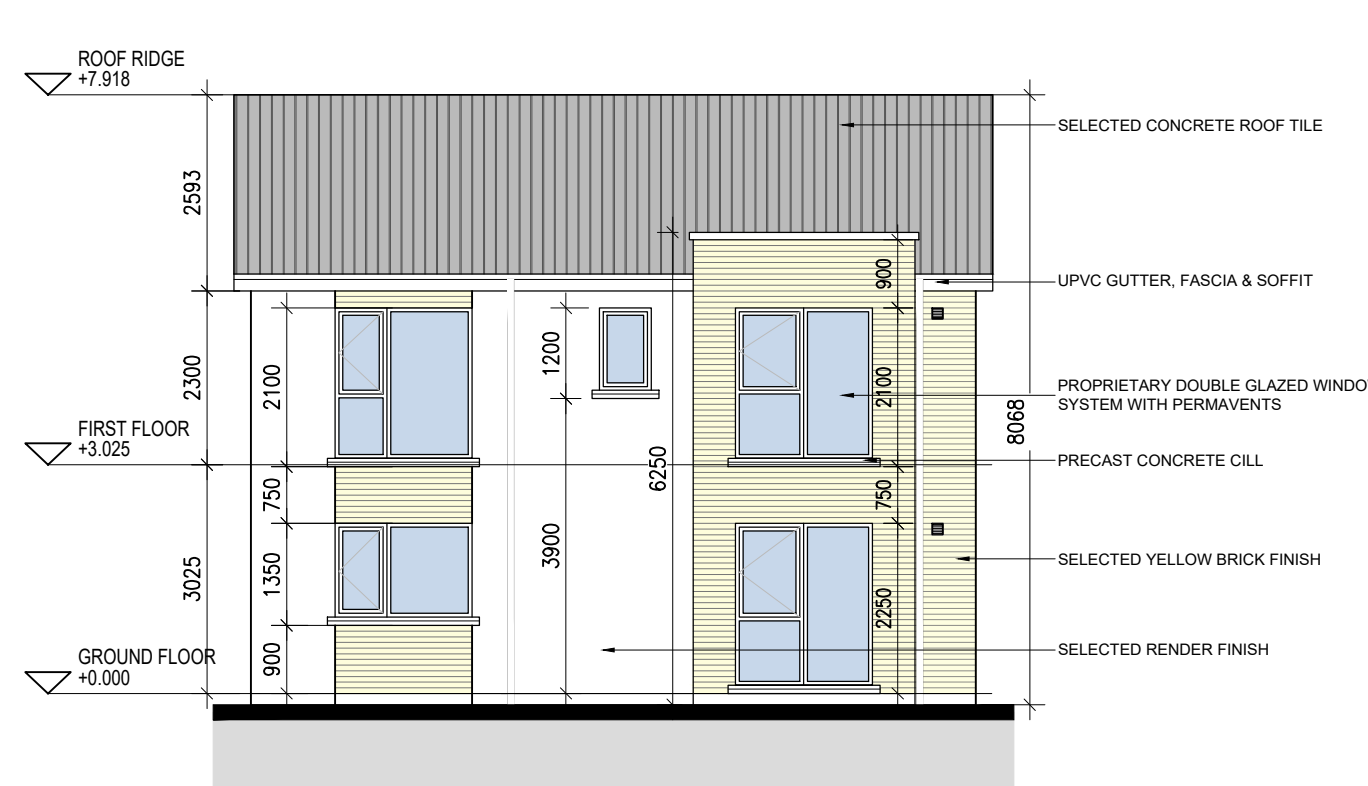

04 TYPE J - SIDE ELEVATION - ROWAN
1:100@A1

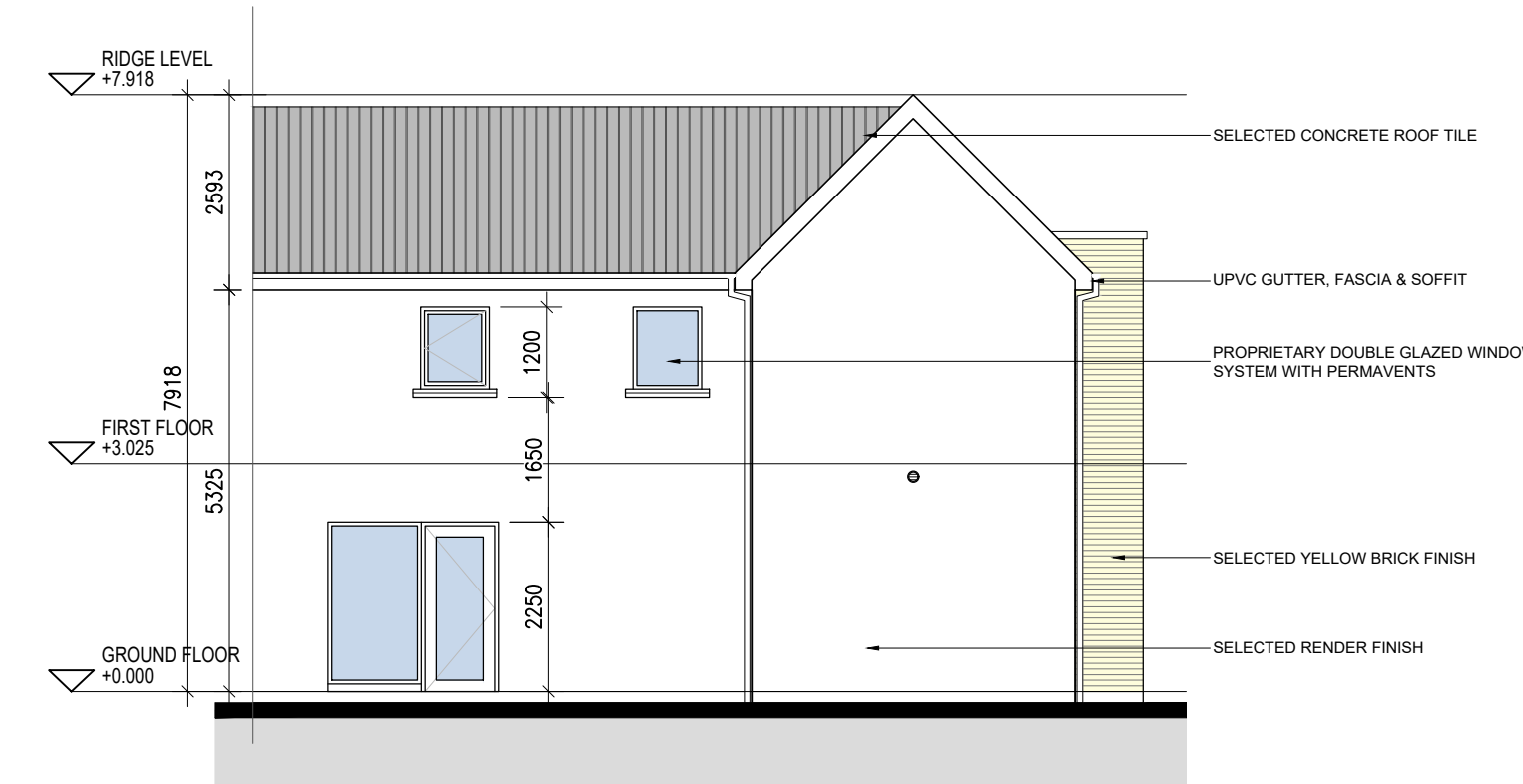

05 TYPE J - REAR ELEVATION
1:100@A1

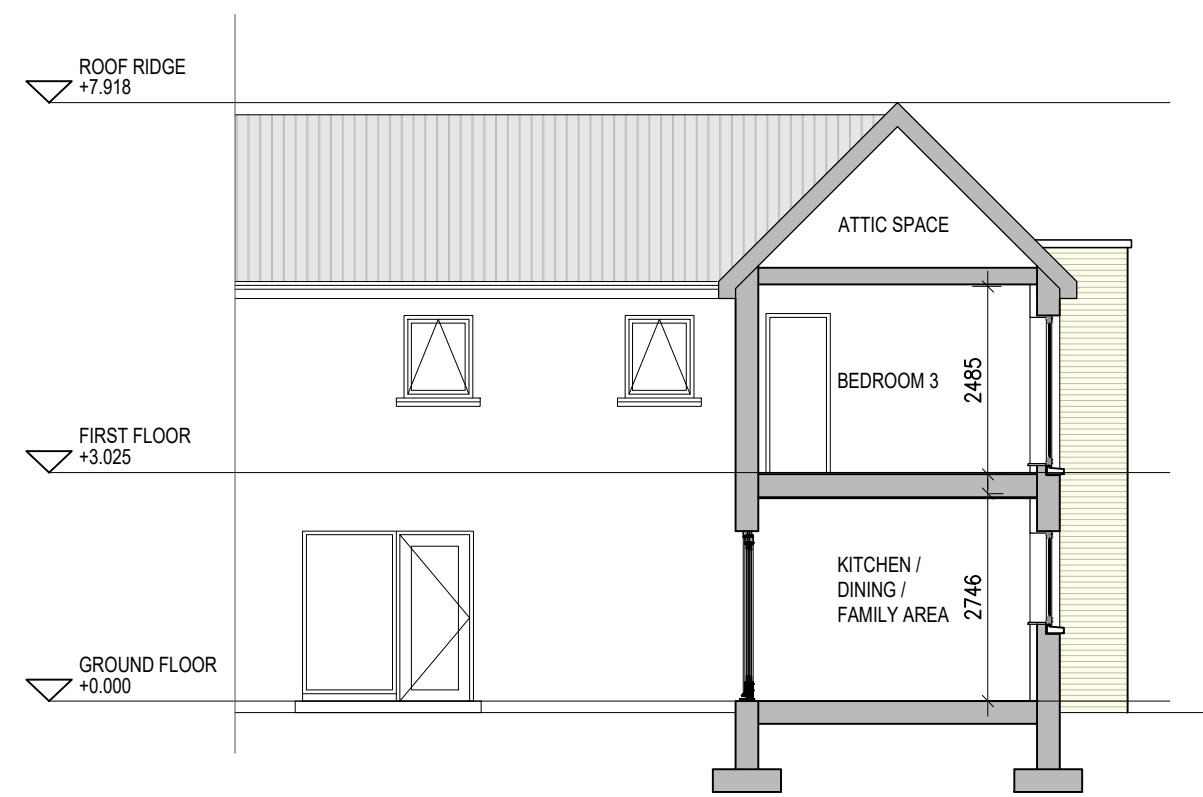

06 TYPE J - SECTION A-A
1:100@A1

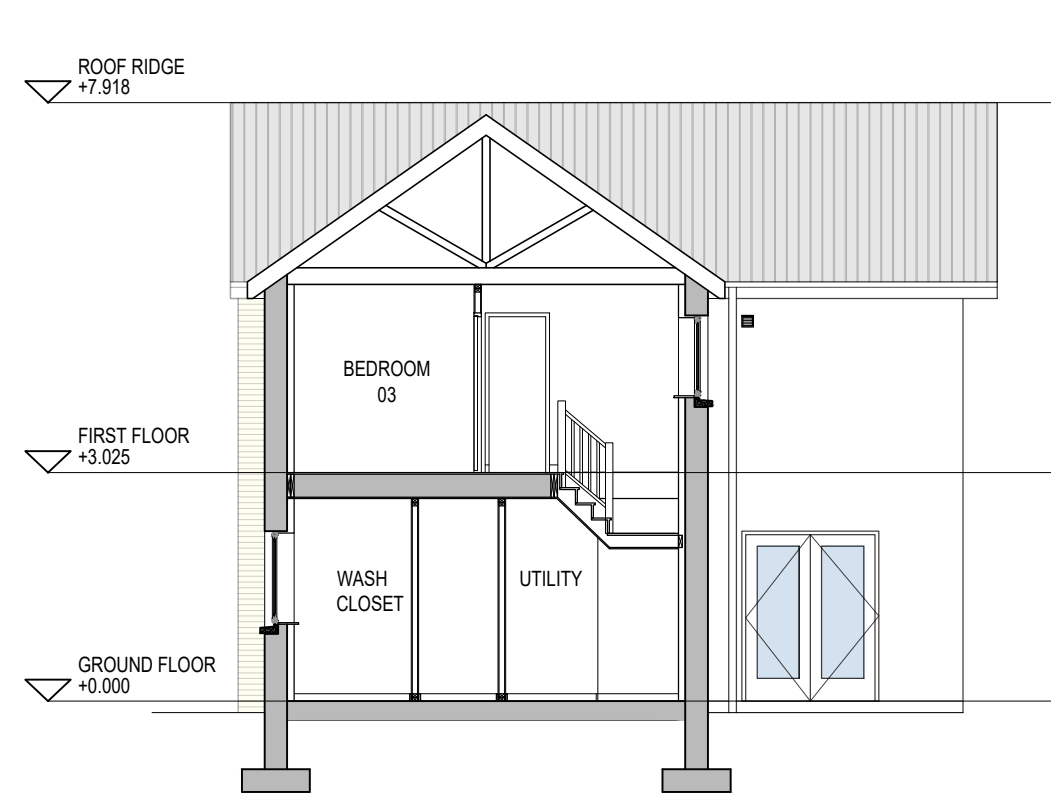

07 TYPE J - SECTION B-B
1:100@A1

Notes	Issue Status
1. Copyright Reserved	
2. Work to figured dimensions only. Do not scale drawing	
3. The contractor is responsible for checking all levels and dimensions on site and shall refer all discrepancies to the Architect	
4. Where appropriate, for details of r.c. structure, or mechanical and electrical details, see Engineers drawings	
5. Proprietary items shall be fixed in strict accordance with manufacturers instructions.	
6. Sizes of proprietary items shall be checked with manufacturer.	
7. The contractor shall be responsible for the coordination of structure, finishes and services.	
Information Only Wide Frontage.dwg 23/11/2023	

No.	Date	Revision	Initials
01	13/1/23	Draft Issue For Discussion	ED
02	23/11/23	Part 8 Issue	ED

REFER ALSO TO SITE SETTING-OUT PLANS AND ELEVATIONS

J	4 BED - 7 PERSON HOUSE PRIVATE	GROUND FLOOR	FIRST FLOOR	N/A	TOTAL AREA
		67.8m ²	67.8m ²		135.6m ²
Project		RESIDENTIAL DEVELOPMENT AT UPPER NANGOR ROAD, KILCABERY, CO. DUBLIN			
Drawing Title		HOUSE TYPE J PLANS, ELEVATIONS & SECTION			
Drawing No		6168A-P-406			
Scale	1:100@A1	Rev	02	Drawn	
Date	23/11/23				

6-7 HARCOURT TERRACE, DUBLIN 2, IRELAND
t +353-1-618 2400 f +353-1-676 7396
www.bkd.ie

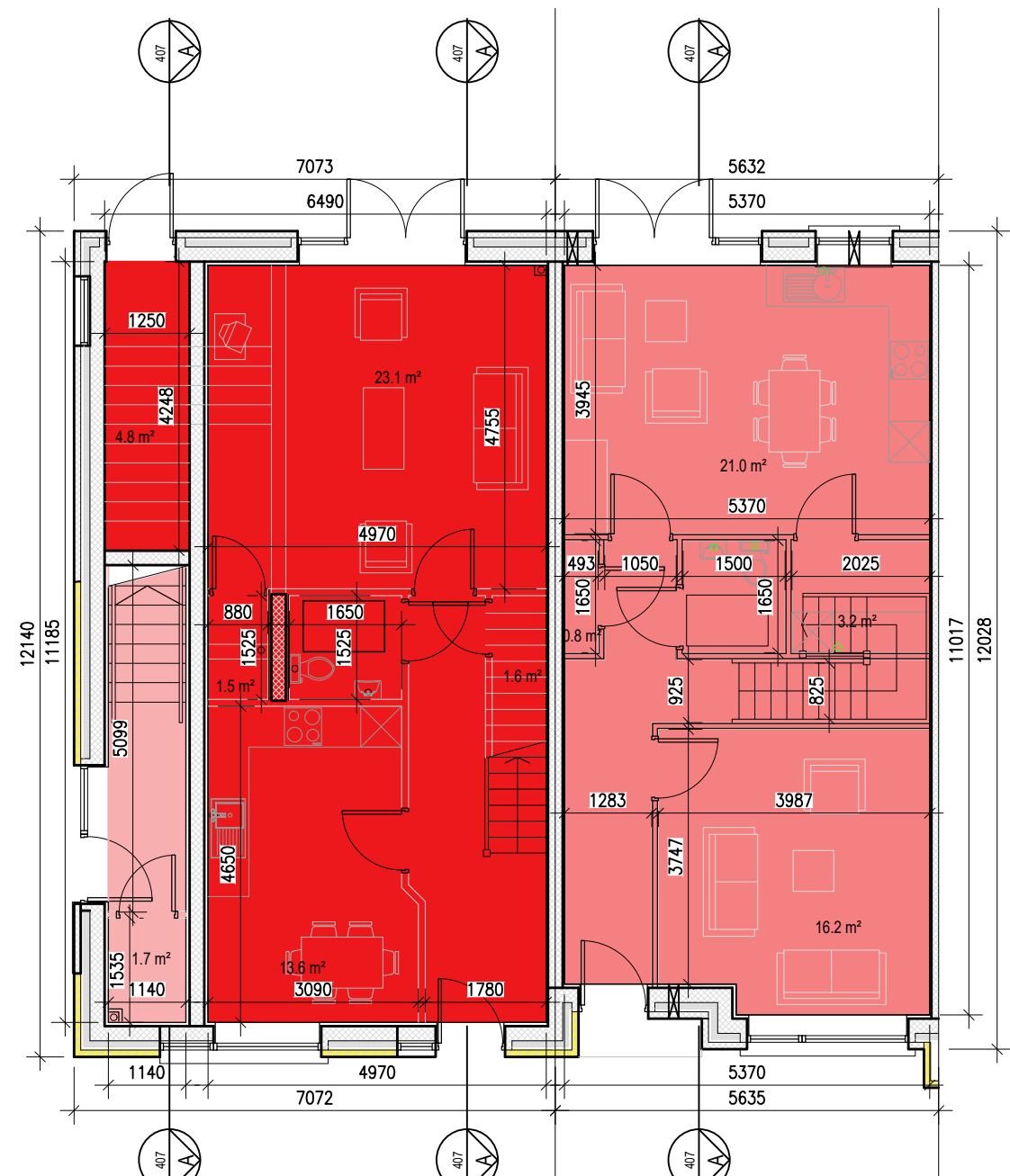

01 APARTMENT DUPLEX UNIT TYPE K, L & L1 - GROUND FLOOR PLAN

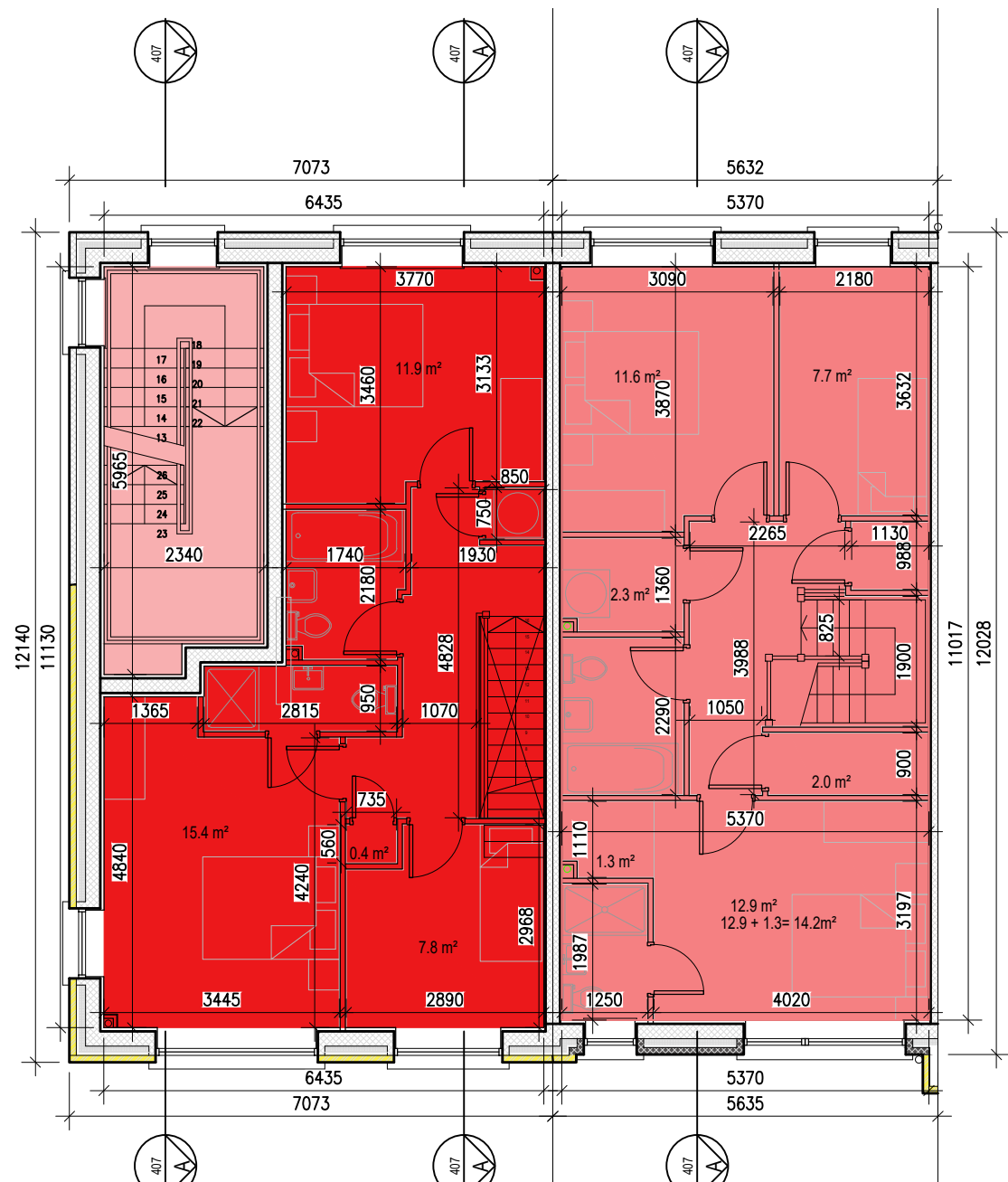

02 APARTMENT DUPLEX UNIT TYPE K, L & L1 - FIRST FLOOR PLAN

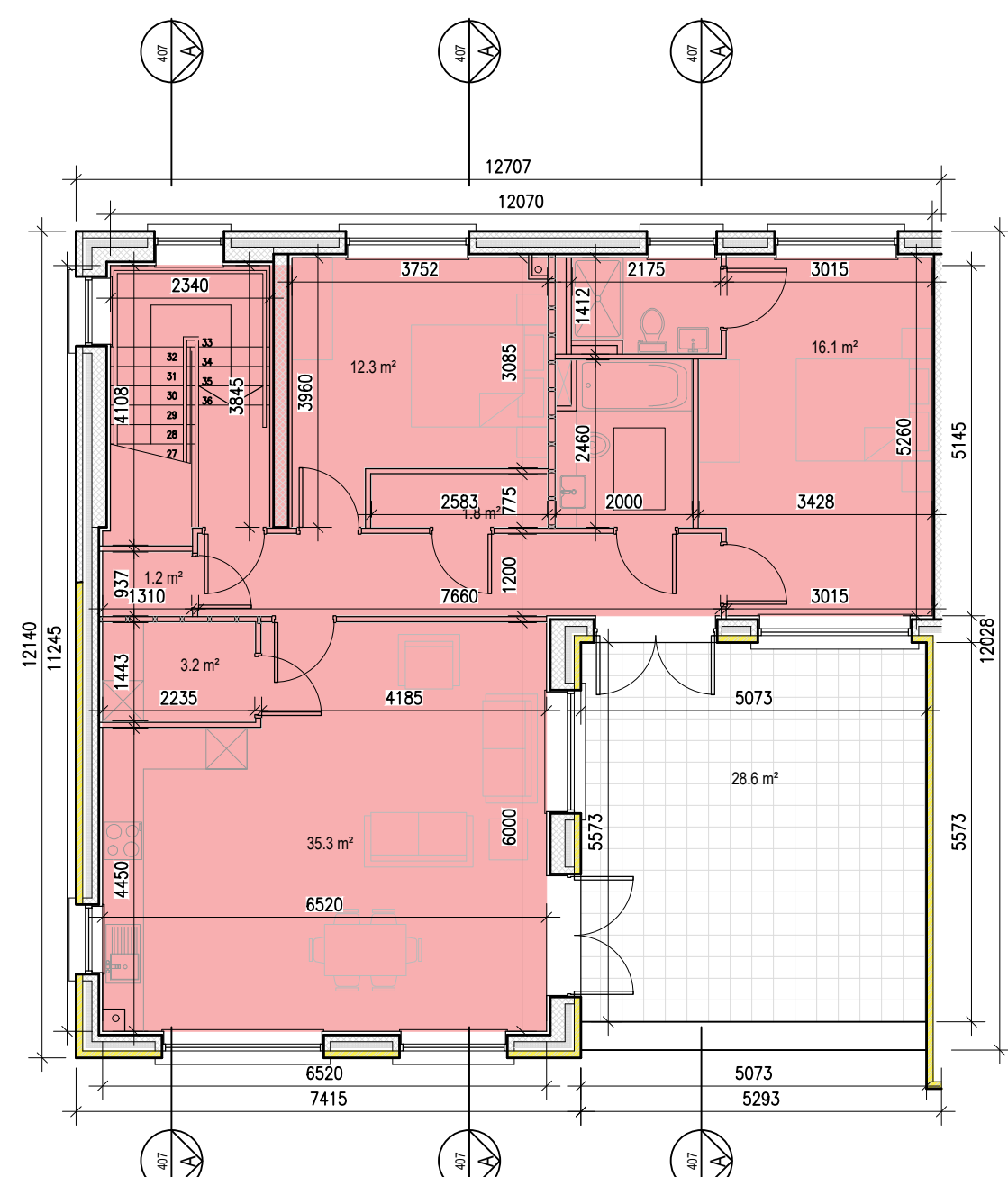

03 APARTMENT DUPLEX UNIT TYPE K, L & L1 - SECOND FLOOR PLAN



00 KEY PLAN

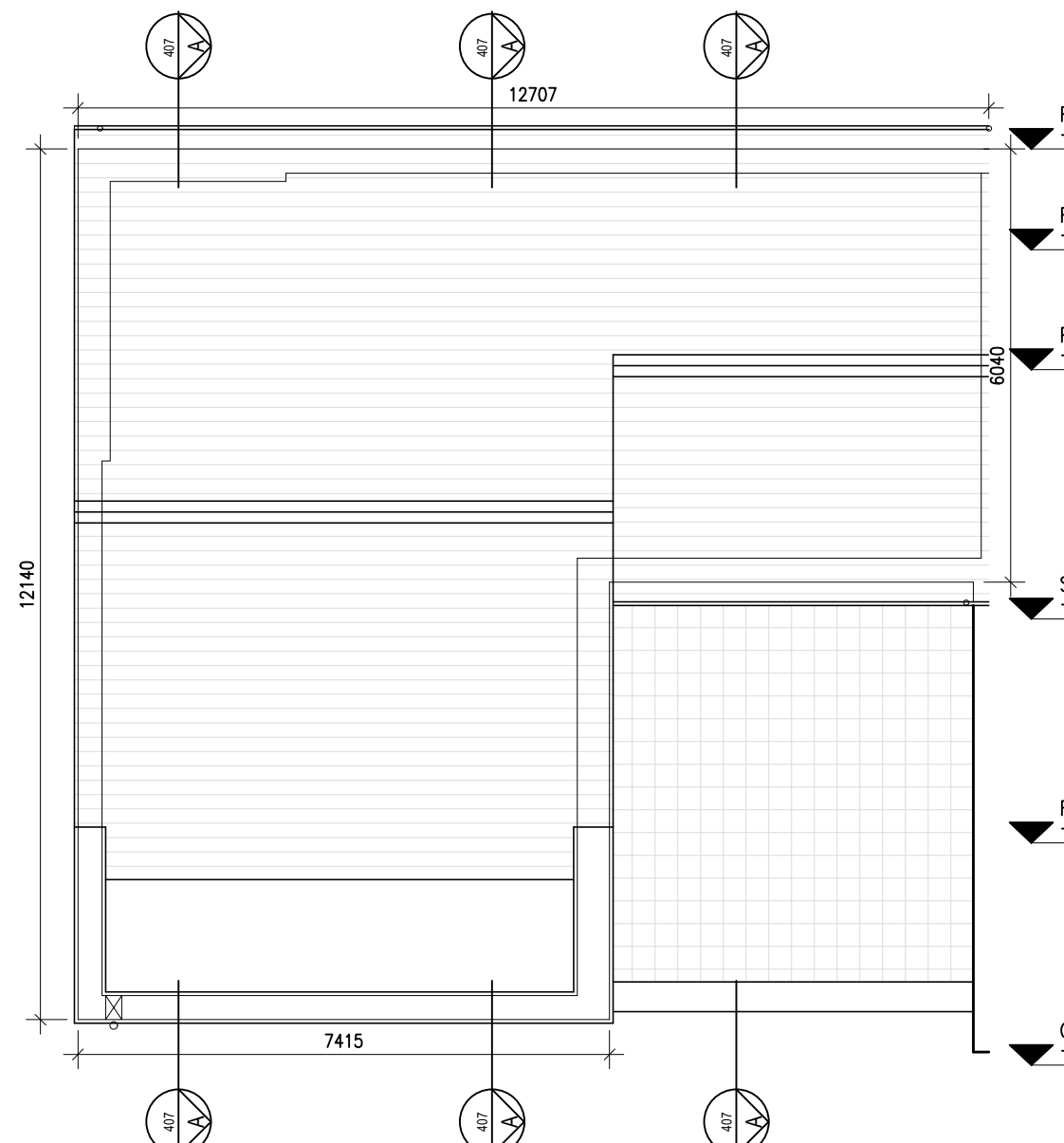

04 APARTMENT DUPLEX UNIT TYPE K, L & L1 - ROOF PLAN



05 APARTMENT DUPLEX UNIT TYPE K, L & L1 - FRONT ELEVATION



06 APARTMENT DUPLEX UNIT TYPE K, L & L1 - REAR ELEVATION

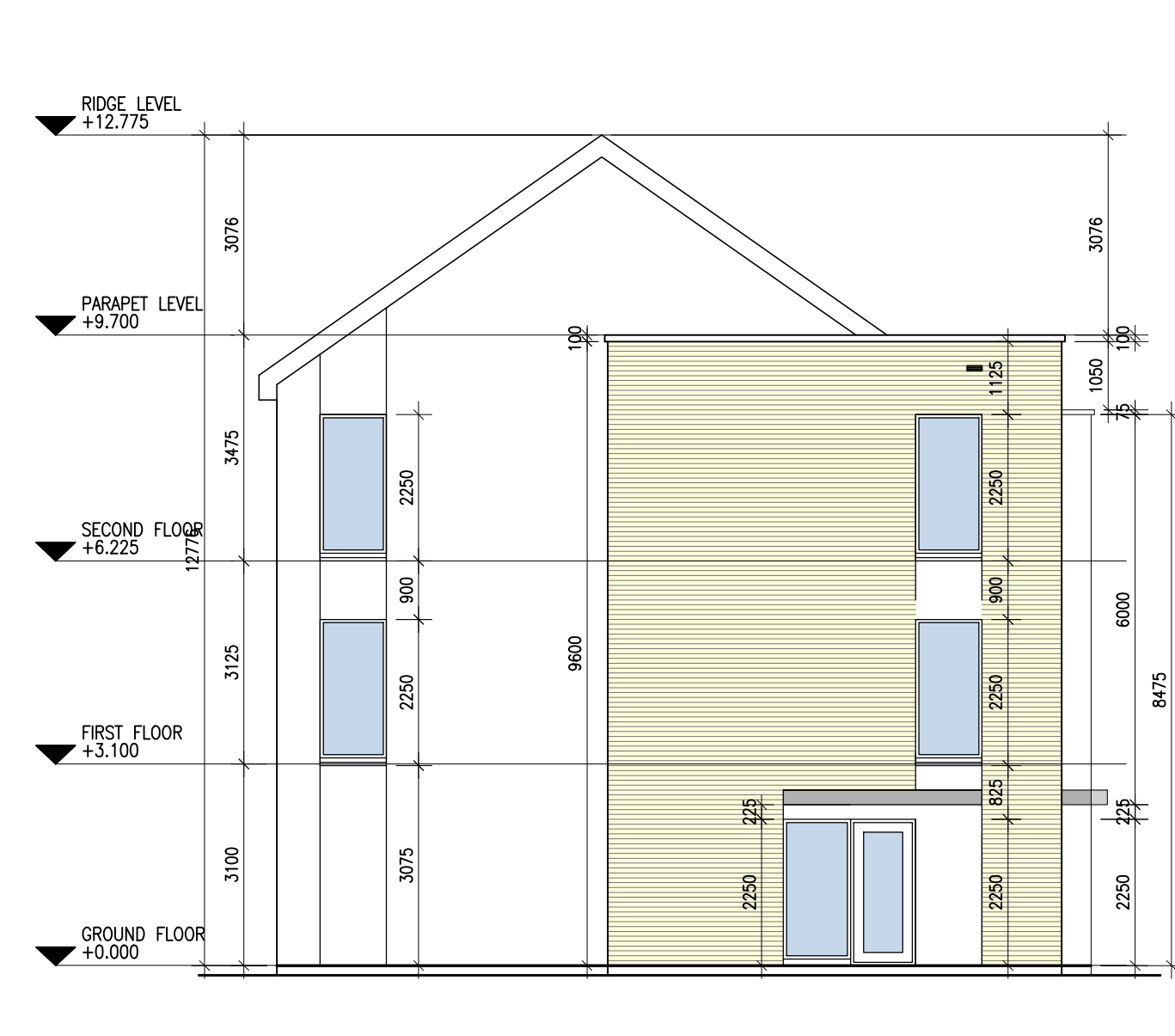

07 APARTMENT DUPLEX UNIT TYPE K, L & L1 - SIDE ELEVATION

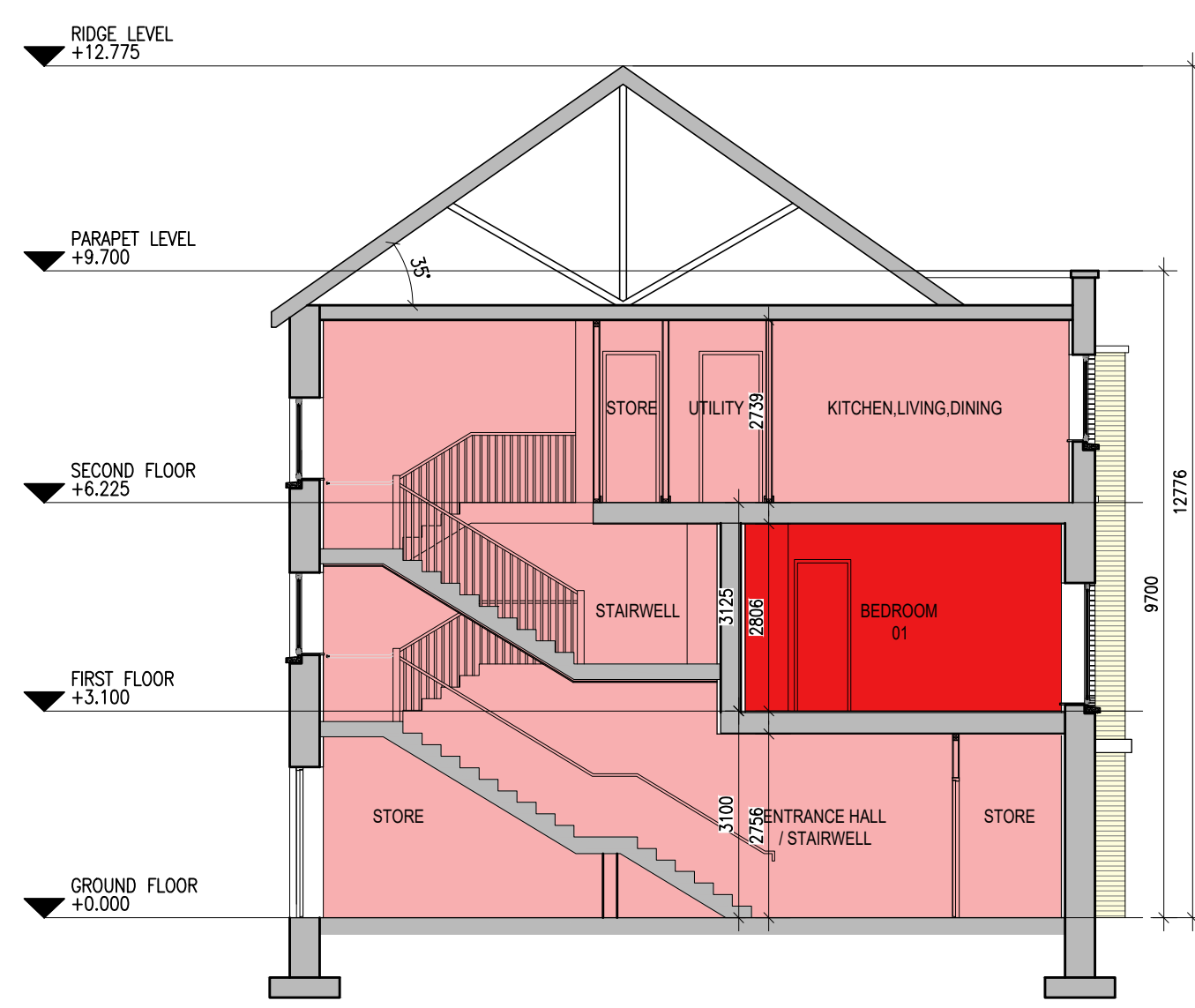

08 APARTMENT DUPLEX UNIT TYPE K, L & L1 - SECTION A-A

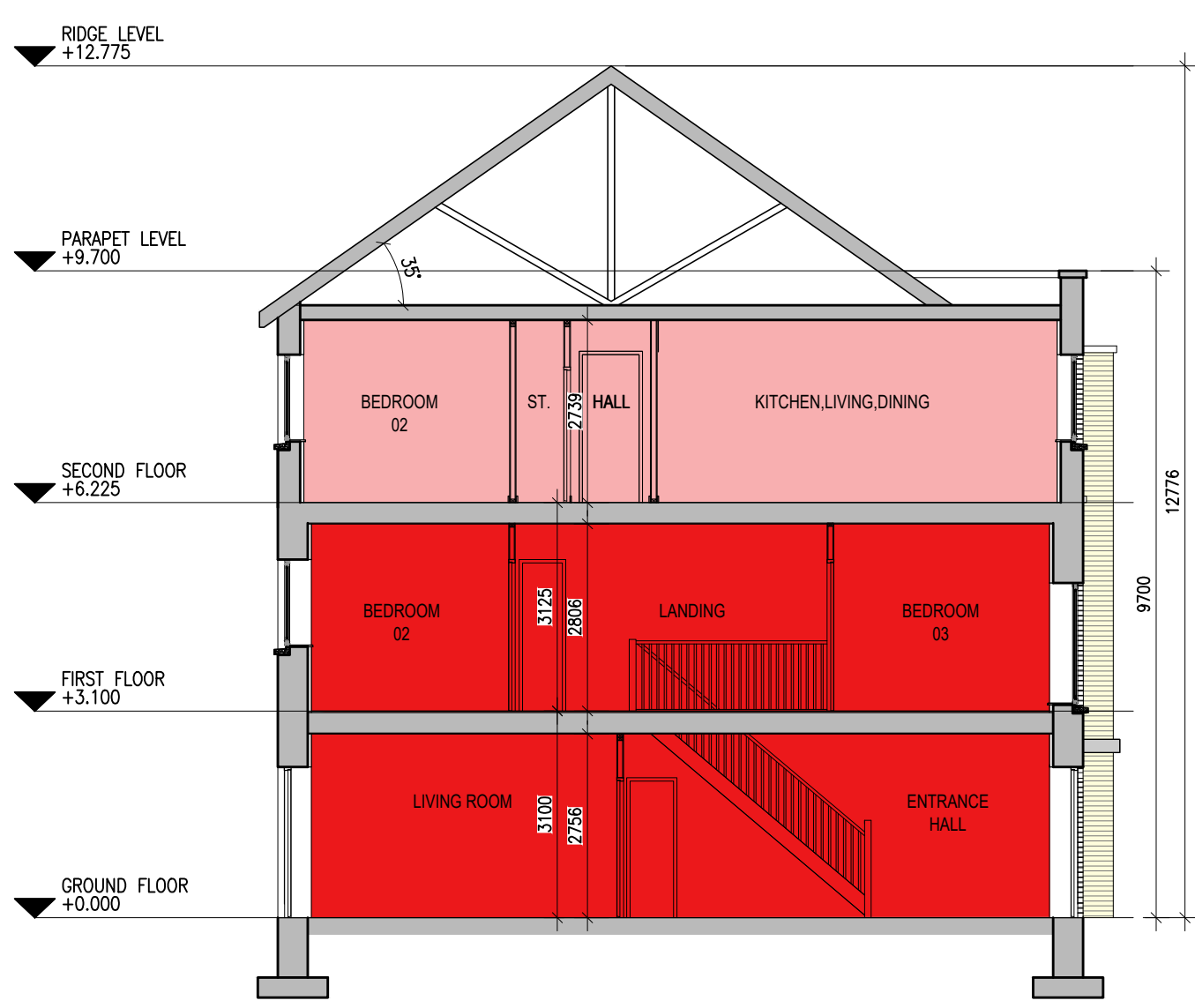

09 APARTMENT DUPLEX UNIT TYPE K, L & L1 - SECTION B-B

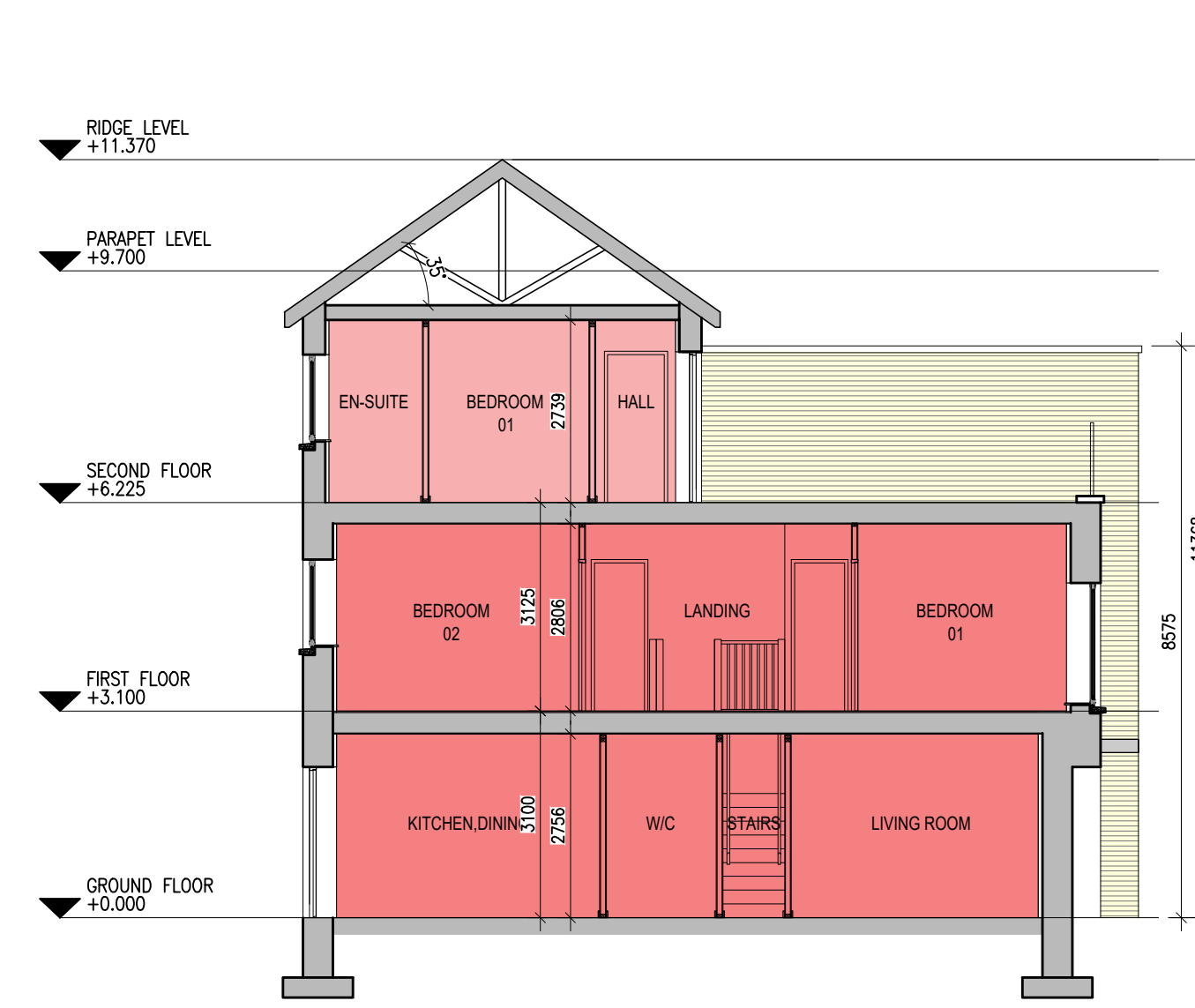

10 APARTMENT DUPLEX UNIT TYPE K, L & L1 - SECTION C-C

Unit Type	Description	Ground Floor	First Floor	Second Floor	Total Area
K	2 BED - 4 PERSON APARTMENT	N/A	N/A	92.0m ²	92.0m ²
L	3 BED - 5 PERSON DUPLEX	54.6m ²	55.4m ²	N/A	110.0m ²
L1	3 BED - 5 PERSON DUPLEX	58.0m ²	59.1m ²	N/A	117.1m ²

REFER TO SITE PLAN FOR LEVELS

Notes
 1. Copyright Reserved
 2. Work to agreed dimensions only. Do not scale drawing
 3. The contractor is responsible for checking all levels and dimensions on site and shall refer all discrepancies to the Architect
 4. Where appropriate, for details of r.c. structure, or mechanical and electrical details, see Engineers drawings
 5. Proprietary items shall be fixed in strict accordance with manufacturers instructions.
 6. Sizes of proprietary items shall be checked with manufacturer.
 7. The contractor shall be responsible for the coordination of structure, finishes and services.

Issue Status	Progress
Planning Application	■
Fire Cert	
Disability Cert	
Tender	
Construction	
As Built	
Information Only	

No.	Date	Revision	Initials
01	13/11/23	Draft Issue For Discussion	ED
02	23/11/23	Part 8 Issue	ED

Project	RESIDENTIAL DEVELOPMENT AT UPPER NANGOR ROAD, KILCARRBERY, CO. DUBLIN
Drawing Title	DUPLEX BLOCK TYPE K, L & L1 - PLANS, ELEVATIONS & SECTIONS
Drawing No	6158A-P-407
Scale	1:100@A1
Rev	02
Drawn	ED
Date	23/11/23

bkdarchitects
 BURKE-KENNEDY DOYLE
 6-7 HARICOURT TERRACE, DUBLIN 2, IRELAND
 T +353-1-618 2400 F +353-1-676 7366
 www.bkd.ie

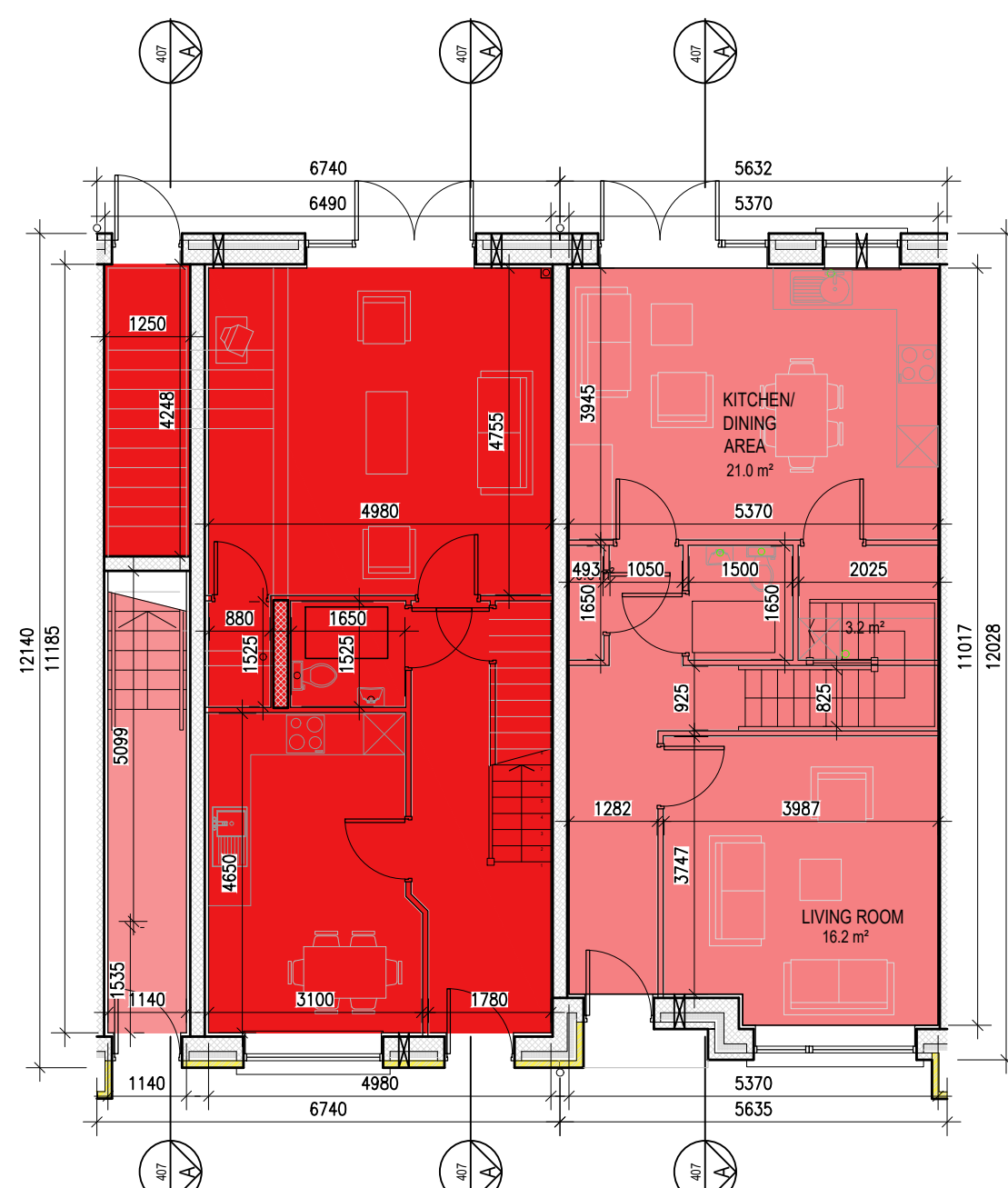

01 APARTMENT DUPLEX UNIT TYPE K1, L4 & L5 - GROUND FLOOR PLAN
1:100@A1

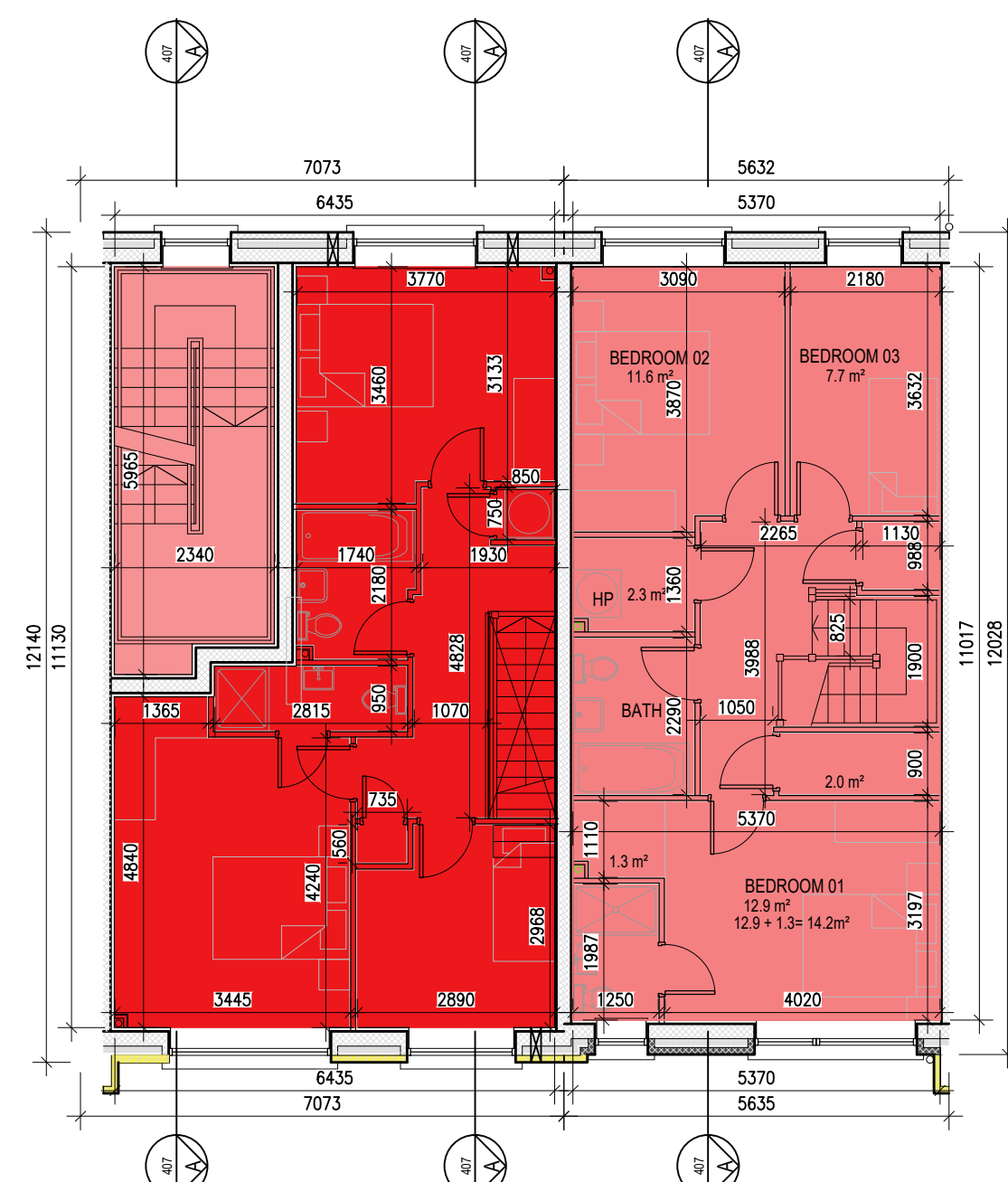

02 APARTMENT DUPLEX UNIT TYPE K1, L4 & L5 - FIRST FLOOR PLAN
1:100@A1

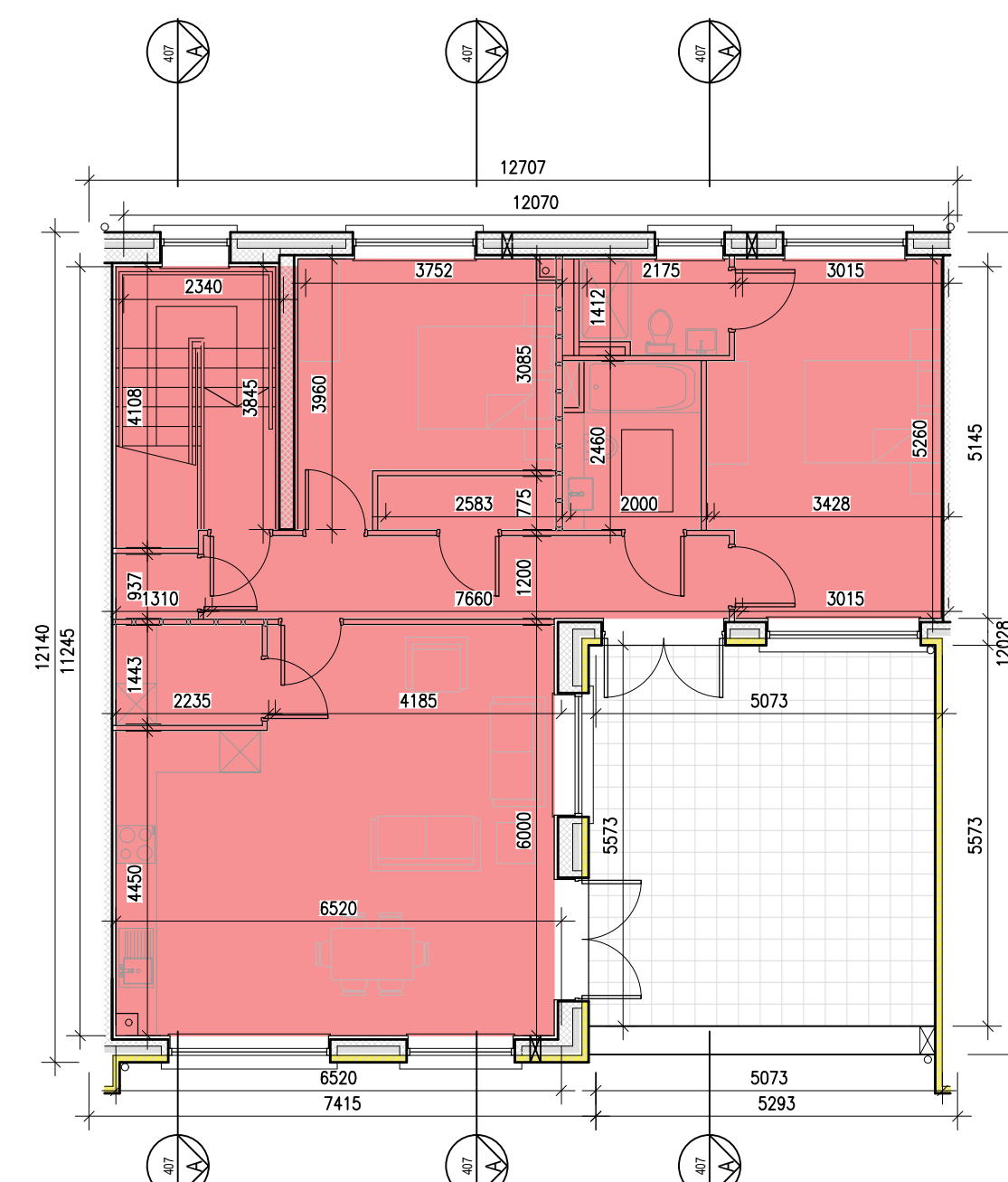

03 APARTMENT DUPLEX UNIT TYPE K1, L4 & L5 - SECOND FLOOR PLAN
1:100@A1

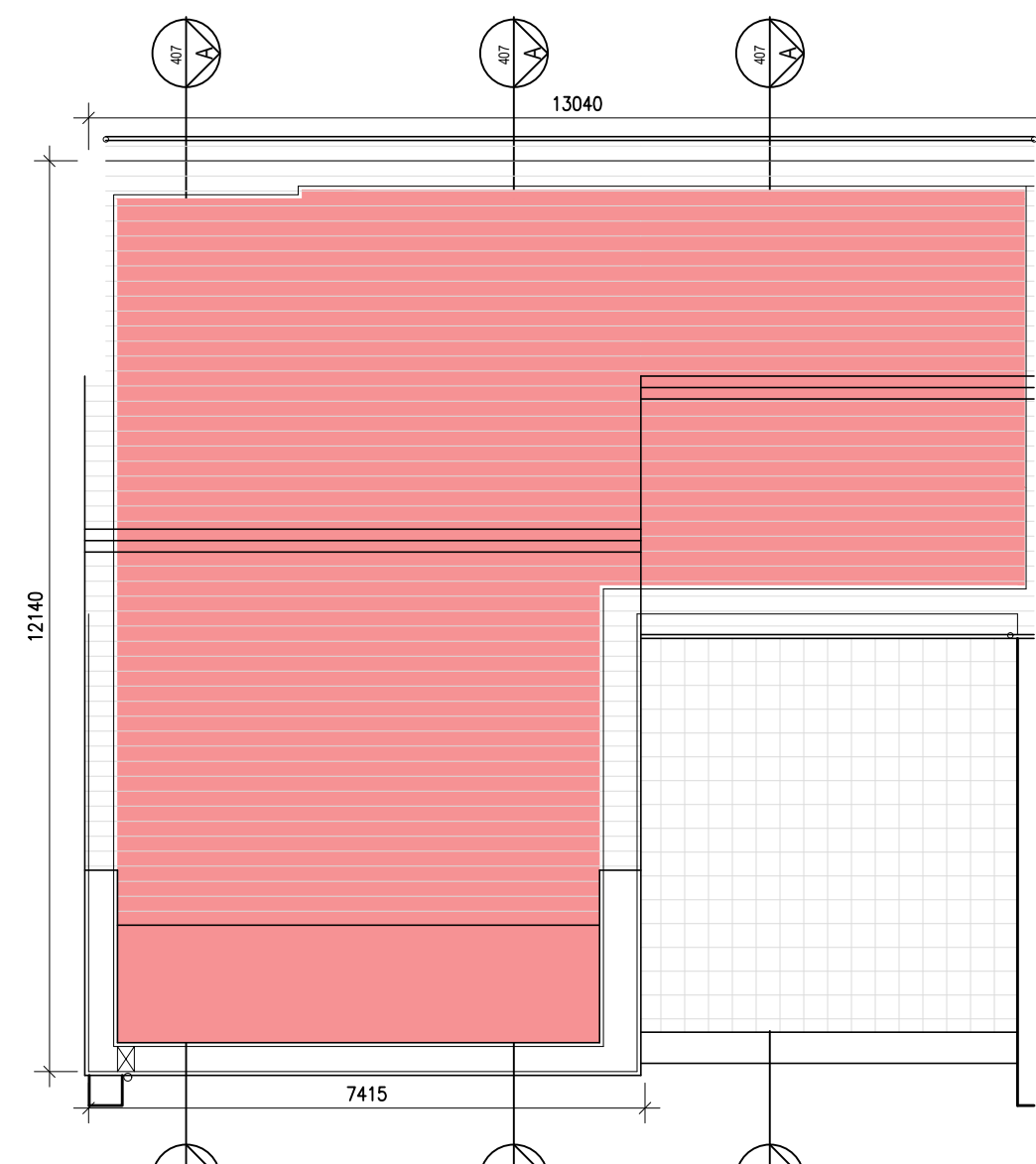

04 APARTMENT DUPLEX UNIT TYPE K1, L4 & L5 - ROOF PLAN
1:100@A1



05 APARTMENT DUPLEX UNIT TYPE K1, L4 & L5 - FRONT ELEVATION
1:100@A1



06 APARTMENT DUPLEX UNIT TYPE K1, L4 & L5 - REAR ELEVATION
1:100@A1

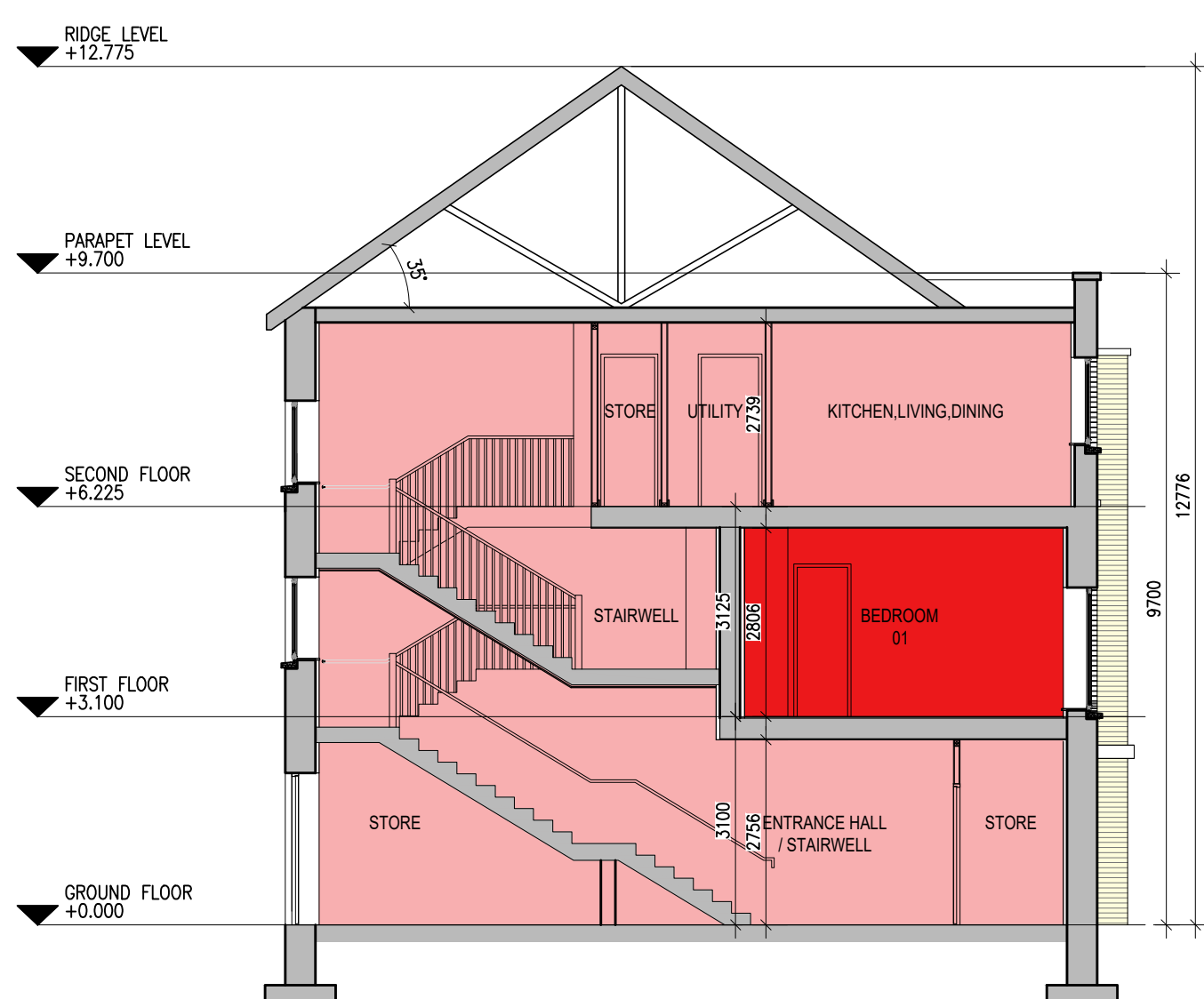

07 APARTMENT DUPLEX UNIT TYPE K1, L4 & L5 - SECTION A-A
1:100@A1

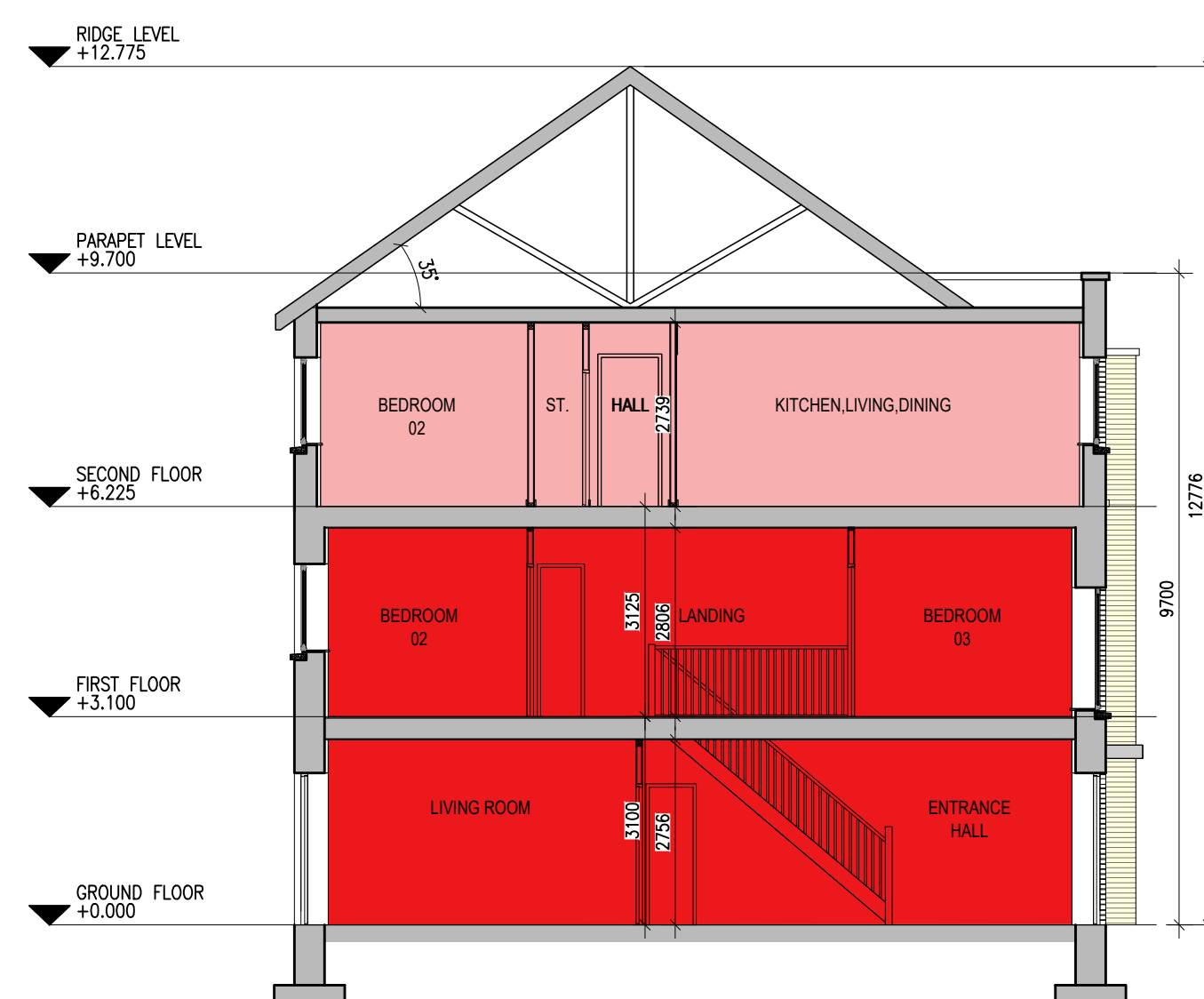

08 APARTMENT DUPLEX UNIT TYPE K1, L4 & L5 - SECTION B-B
1:100@A1

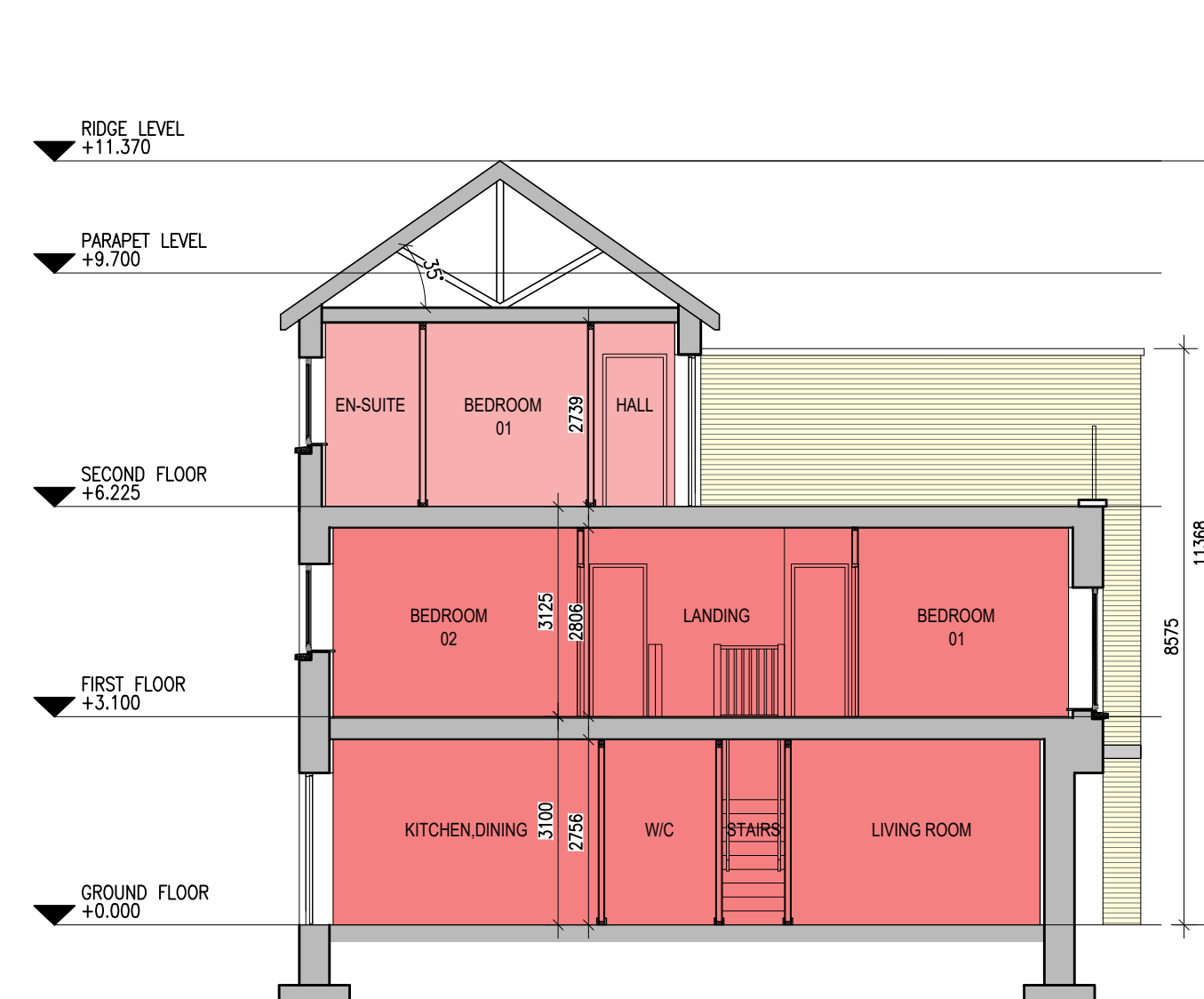

09 APARTMENT DUPLEX UNIT TYPE K1, L4 & L5 - SECTION C-C
1:100@A1

Unit Type	Bedrooms	Persons	Ground Floor	First Floor	Second Floor	Total Area
K1	2	4	N/A	N/A	91.5m ²	91.5m ²
L4	3	5	55.0m ²	55.9m ²	N/A	110.9m ²
L5	3	5	58.0m ²	59.1m ²	N/A	117.1m ²

REFER TO SITE PLAN FOR LEVELS

Notes	Issue Status
1. Copyright Reserved	Progress
2. Work to agreed dimensions only. Do not scale drawing	Planning Application
3. The contractor is responsible for checking all levels and dimensions on site and shall refer all discrepancies to the Architect	Fire Cert
4. Where appropriate, for details of r.c. structure, or mechanical and electrical details, see Engineers Drawings	Disability Cert
5. Proprietary items shall be fixed in strict accordance with manufacturers instructions.	Tender
6. Sizes of proprietary items shall be checked with manufacturer.	Construction
7. The contractor shall be responsible for the coordination of structure, finishes and services.	As Built
	Information Only

No.	Date	Revision	Initials
01	13/11/23	Draft Issue For Discussion	ED
02	23/11/23	Part 8 Issue	ED

Project	RESIDENTIAL DEVELOPMENT AT UPPER NANGOR ROAD, KILCABERY, CO. DUBLIN
Drawing Title	DUPLEX BLOCK TYPE K1, L4 & L5 - PLANS, ELEVATIONS & SECTIONS
Drawing No	6158A-P-408
Scale	1:100@A1
Rev	01
Drawn	ED
Date	23/11/23

6-7 HARDCOURT TERRACE, DUBLIN 2, IRELAND
 T +353-1-618 2400 F +353-1-676 7366
 www.bkd.ie
bkdarchitects
 BURKE-KENNEDY DOYLE

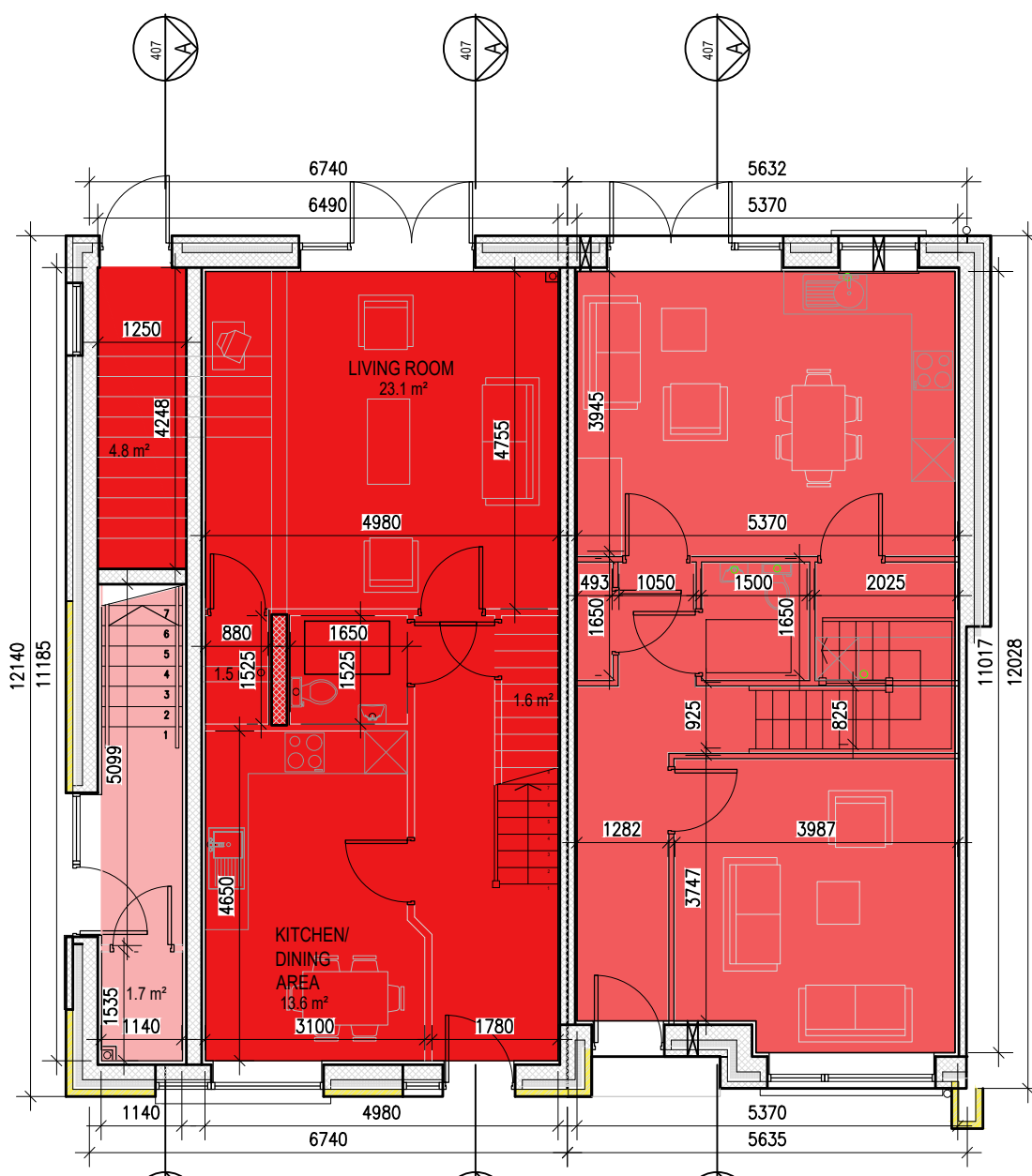

01 APARTMENT DUPLEX UNIT TYPE K2, L6 & L7 - GROUND FLOOR PLAN

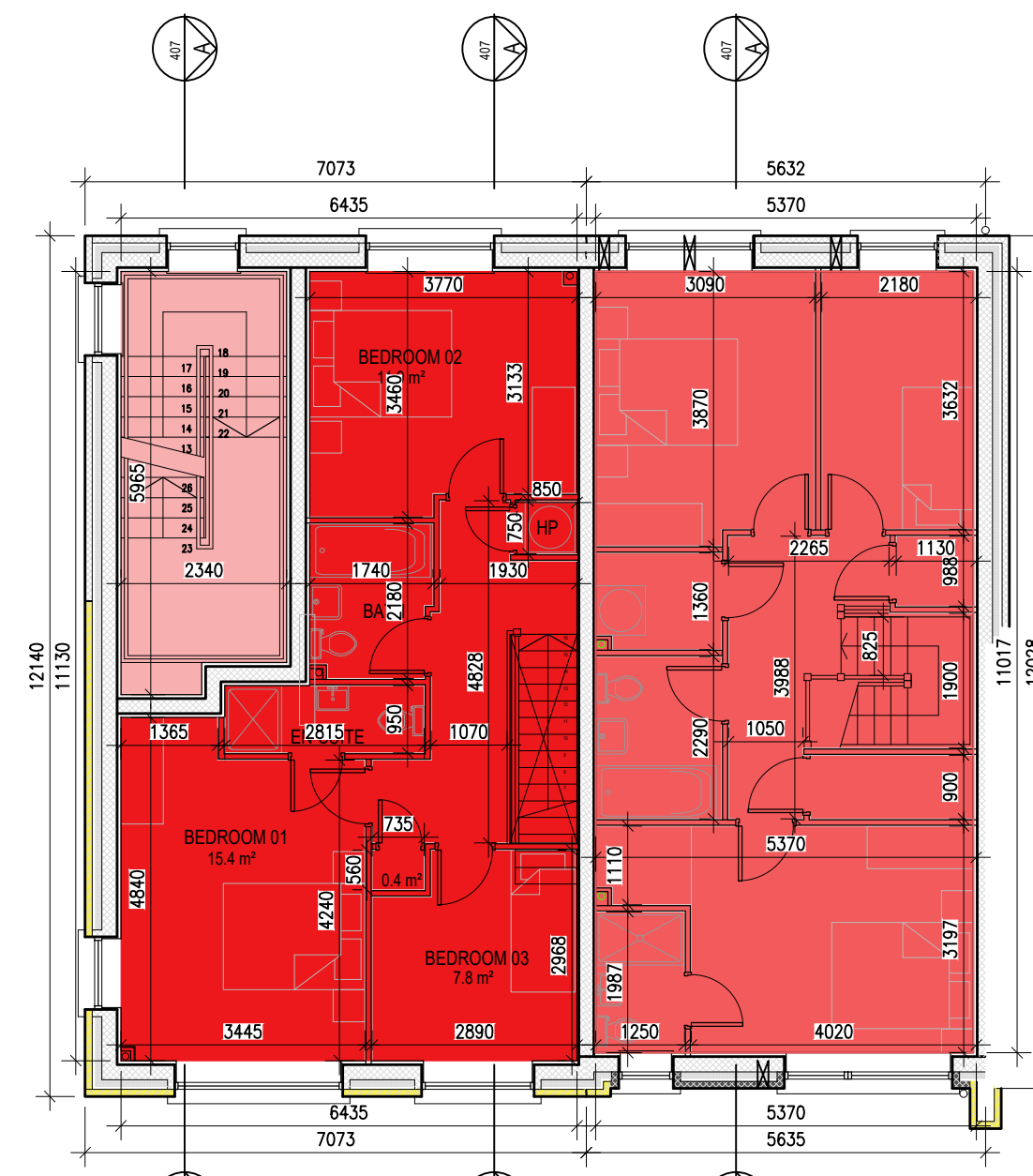

02 APARTMENT DUPLEX UNIT TYPE K2, L6 & L7 - FIRST FLOOR PLAN

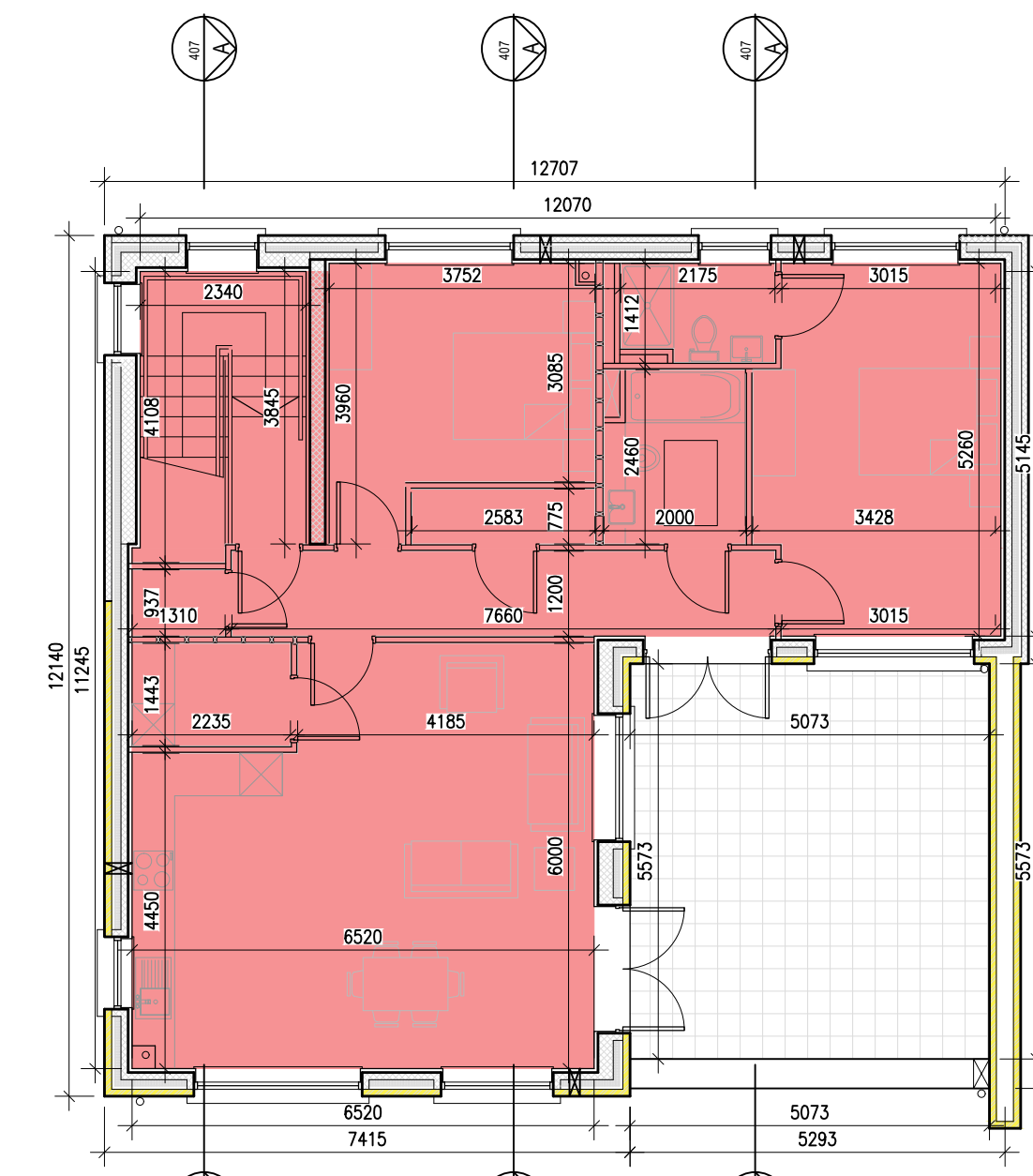

03 APARTMENT DUPLEX UNIT TYPE K2, L6 & L7 - SECOND FLOOR PLAN



00 KEY PLAN

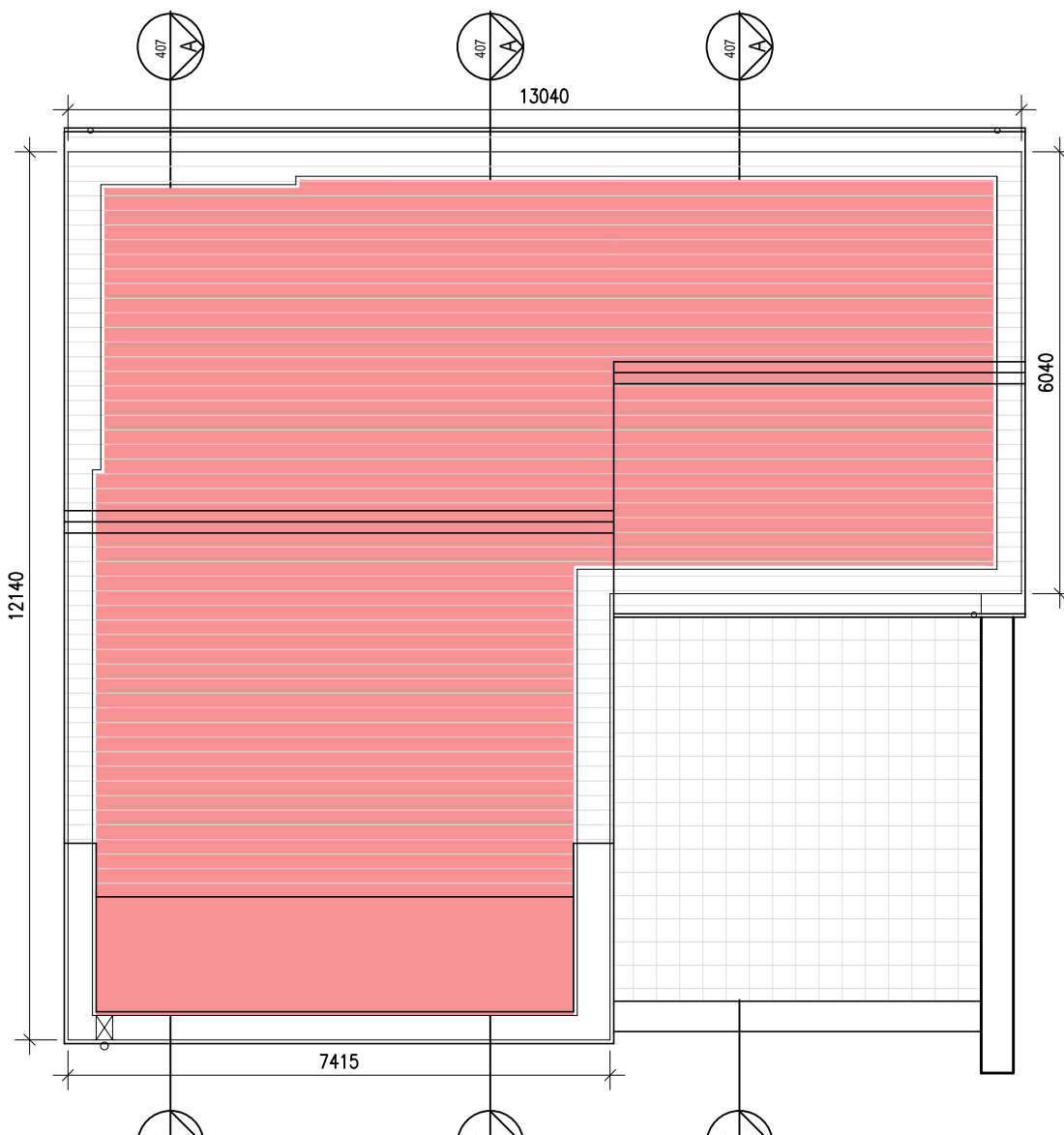

04 APARTMENT DUPLEX UNIT TYPE K2, L6 & L7 - ROOF PLAN



05 APARTMENT DUPLEX UNIT TYPE K2, L6 & L7 - FRONT ELEVATION

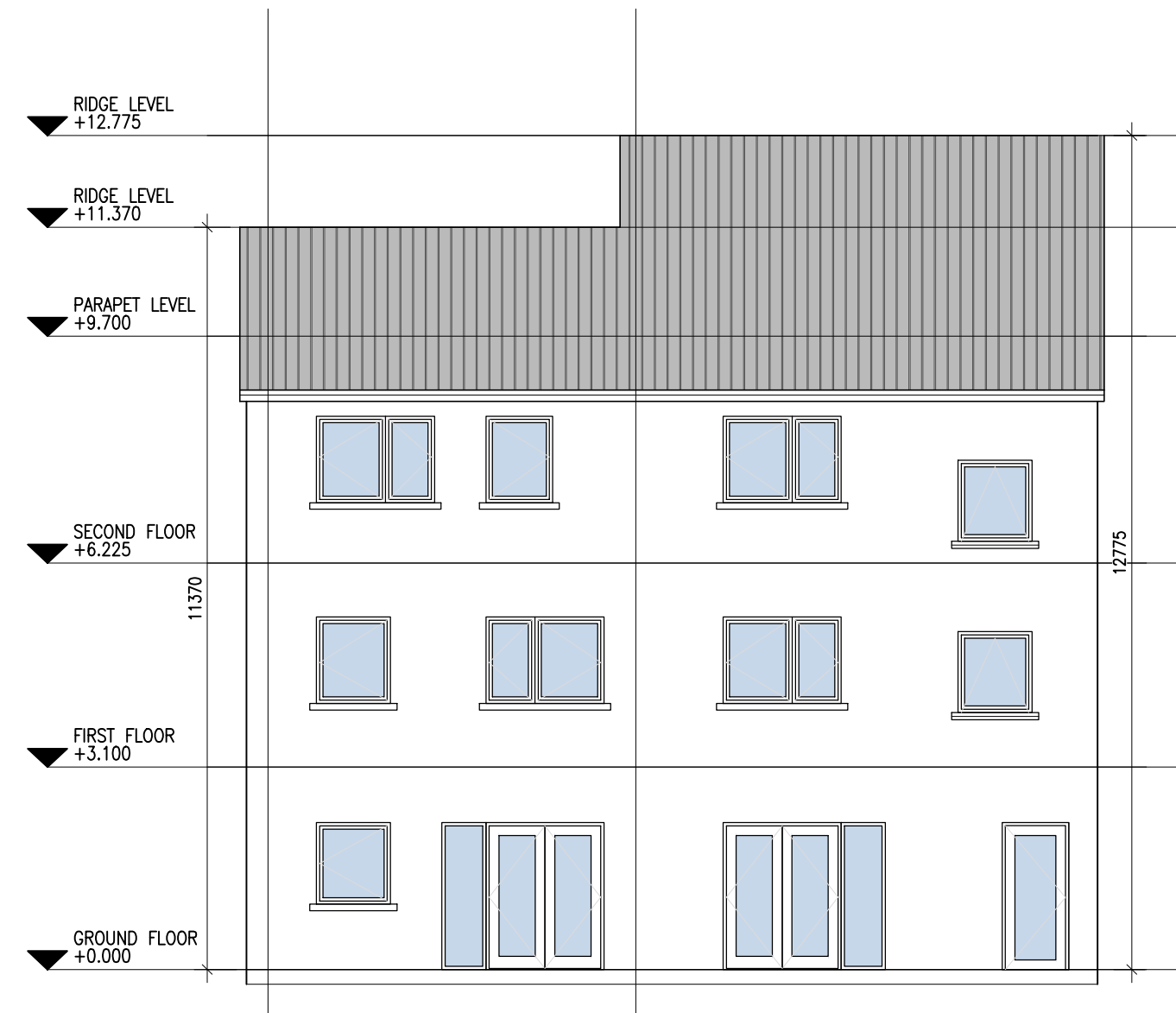

06 APARTMENT DUPLEX UNIT TYPE K2, L6 & L7 - REAR ELEVATION

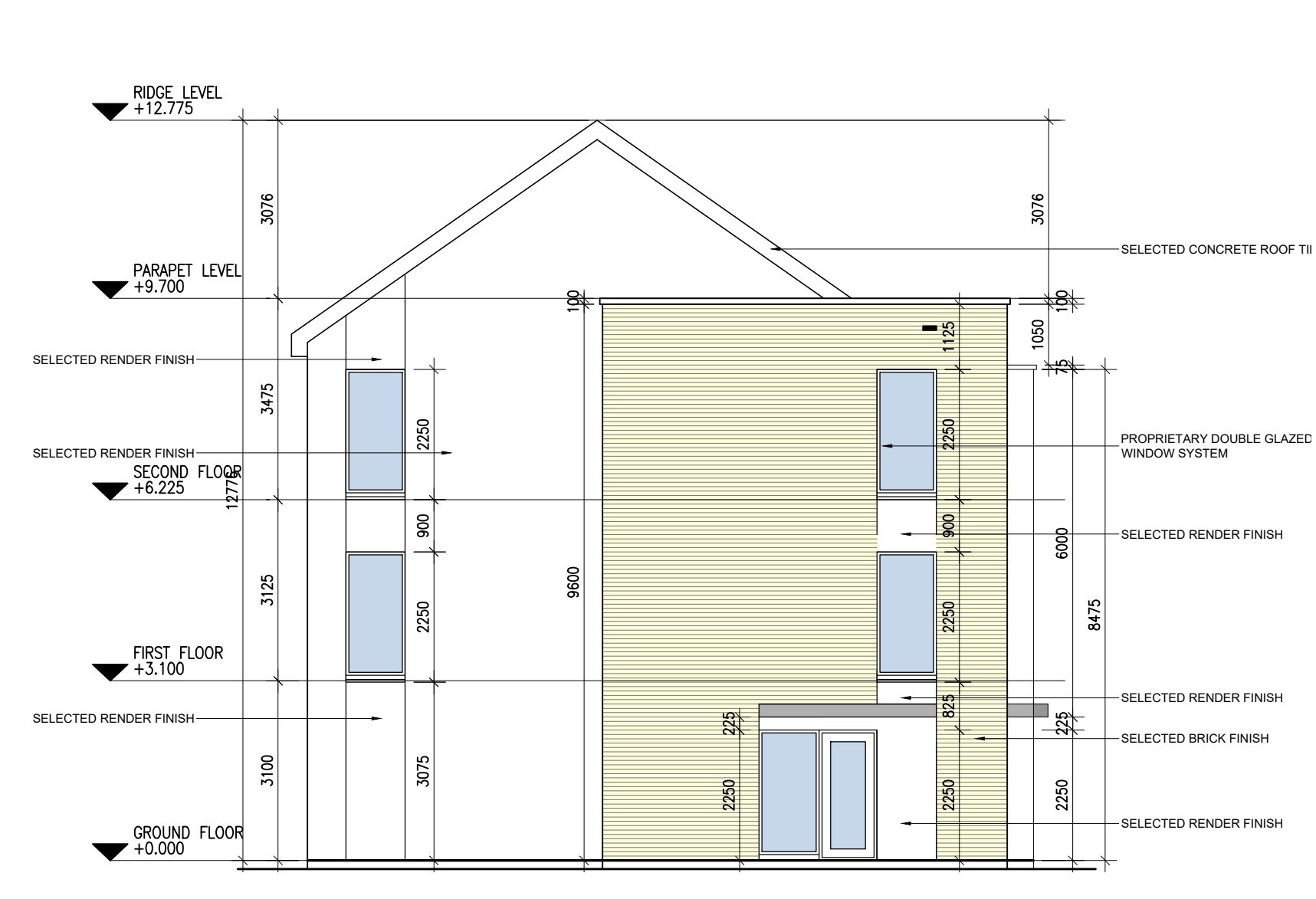

07 APARTMENT DUPLEX UNIT TYPE K, L & L1 - SIDE ELEVATION

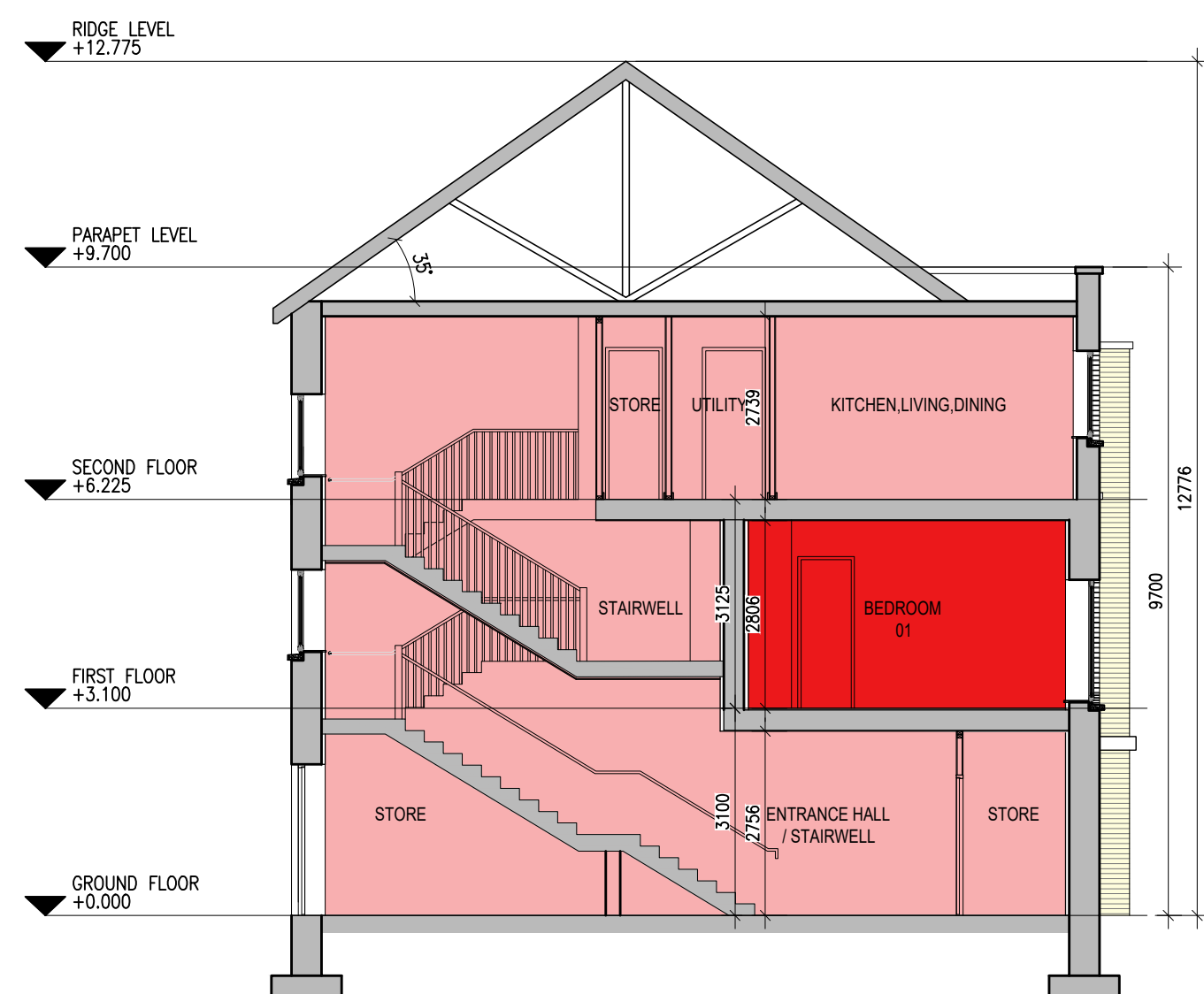

08 APARTMENT DUPLEX UNIT TYPE K2, L6 & L7 - SECTION A-A

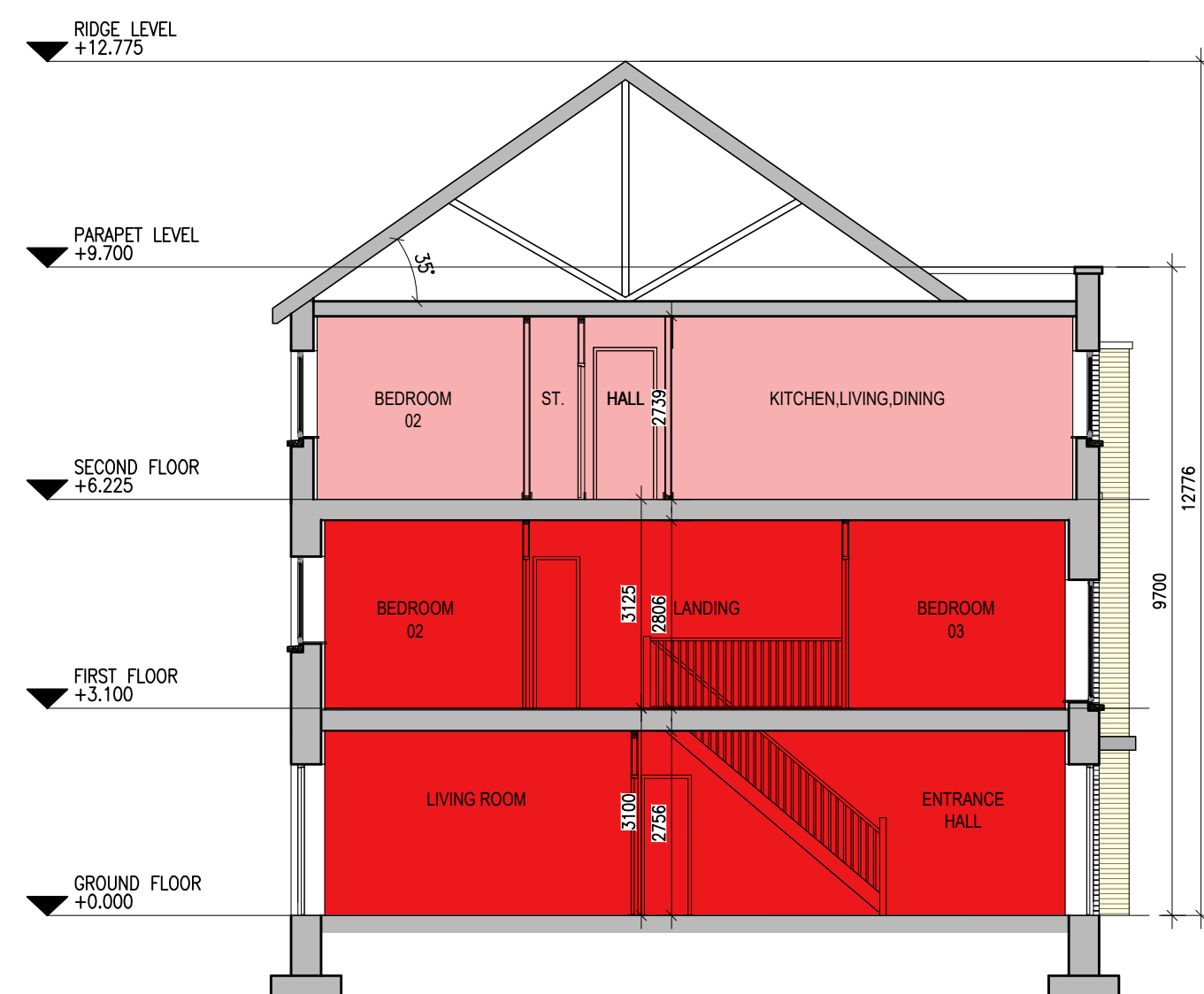

09 APARTMENT DUPLEX UNIT TYPE K2, L6 & L7 - SECTION B-B

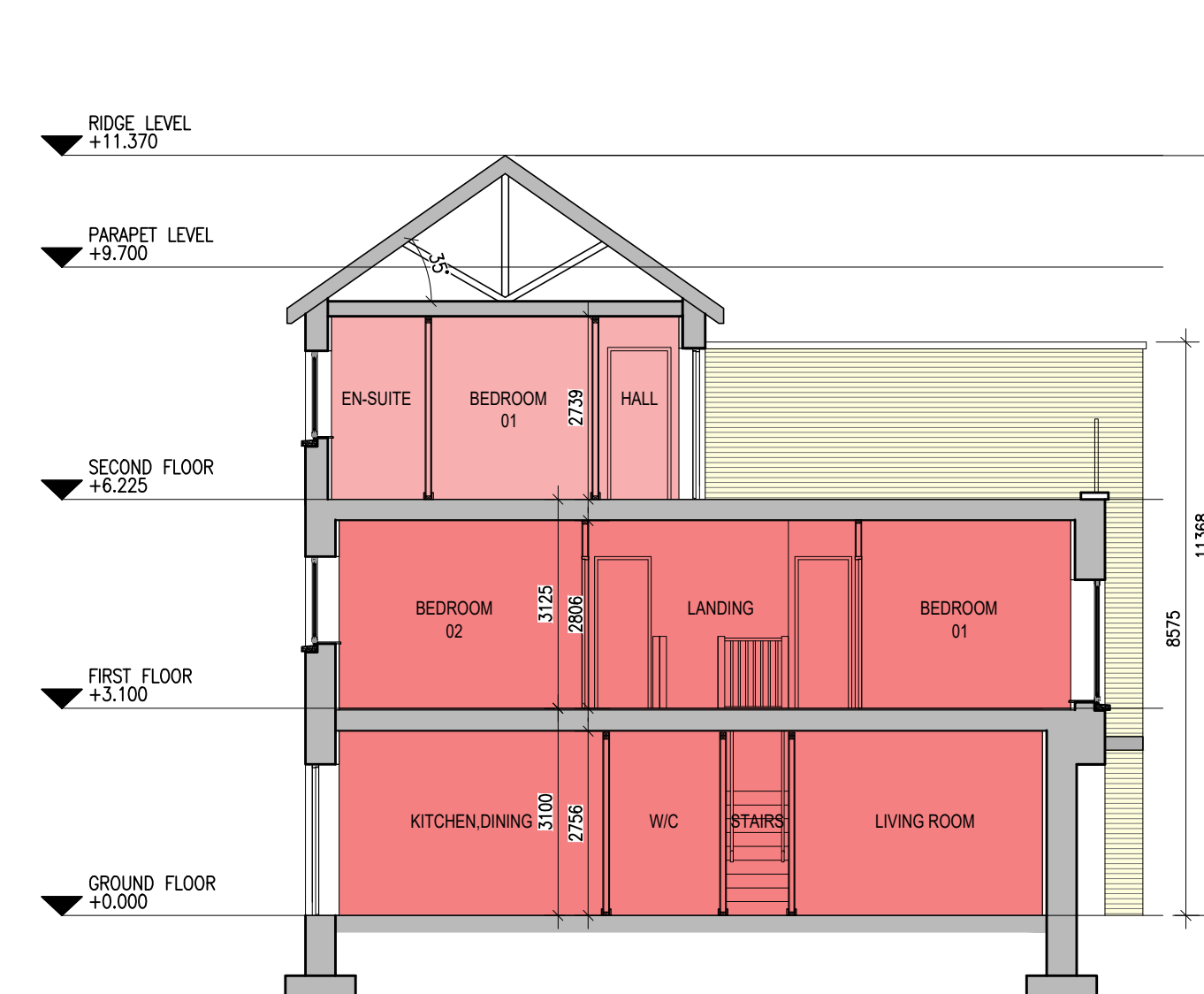

10 APARTMENT DUPLEX UNIT TYPE K2, L6 & L7 - SECTION C-C

Unit Type	Bedrooms	Person Capacity	Ground Floor Area	First Floor Area	Second Floor Area	Total Area
K2	2	4 PERSON	N/A	N/A	92.6m ²	92.6m ²
L6	3	5 PERSON DUPLEX	54.6m ²	55.4m ²	N/A	110.0m ²
L7	3	5 PERSON DUPLEX	57.6m ²	58.7m ²	N/A	116.3m ²

REFER TO SITE PLAN FOR LEVELS

Notes	Issue Status
1. Copyright Reserved	In Progress
2. Work to agreed dimensions only. Do not scale drawing	Planning Application
3. The contractor is responsible for checking all levels and dimensions on site and shall refer all discrepancies to the Architect	Fire Cert
4. Where appropriate, for details of r.c. structure, or mechanical and electrical details, see Engineers drawings	Disability Cert
5. Proprietary items shall be fixed in strict accordance with manufacturers instructions.	Tender
6. Sizes of proprietary items shall be checked with manufacturer.	Construction
7. The contractor shall be responsible for the coordination of structure, finishes and services.	As Built
	Information Only

No.	Date	Revision	Initials
01	13/11/23	Draft Issue For Discussion	ED
02	23/11/23	Part 8 Issue	ED

Project	RESIDENTIAL DEVELOPMENT AT UPPER NANGOR ROAD, KILCABERY, CO. DUBLIN
Drawing Title	DUPLEX BLOCK TYPE K2, L6 & L7 - PLANS, ELEVATIONS & SECTIONS
Drawing No	6158A-P-409
Scale	1:100@A1
Rev	02
Drawn	ED
Date	23/11/23

6-7 HARDCOURT TERRACE, DUBLIN 2, IRELAND
 T: +353-1-678 2400 F: +353-1-678 7366
 www.bkd.ie
bkdarchitects
 BURKE-KENNEDY DOYLE

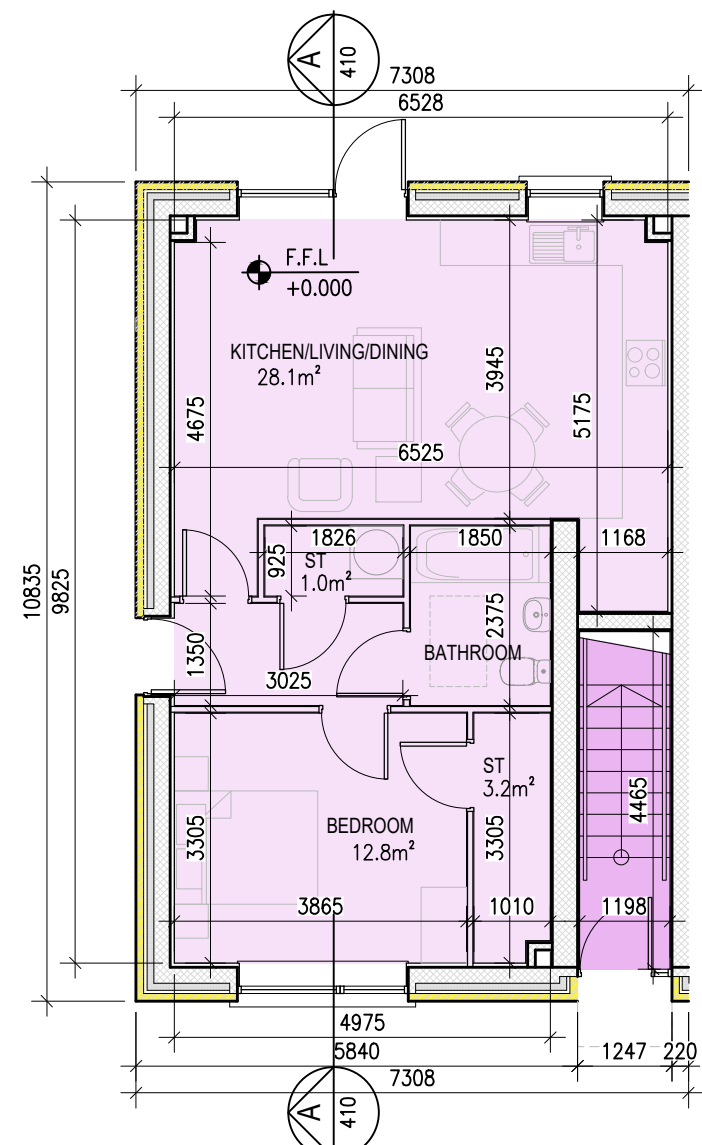

01 TYPE M - GROUND FLOOR PLAN
1:1000 A1

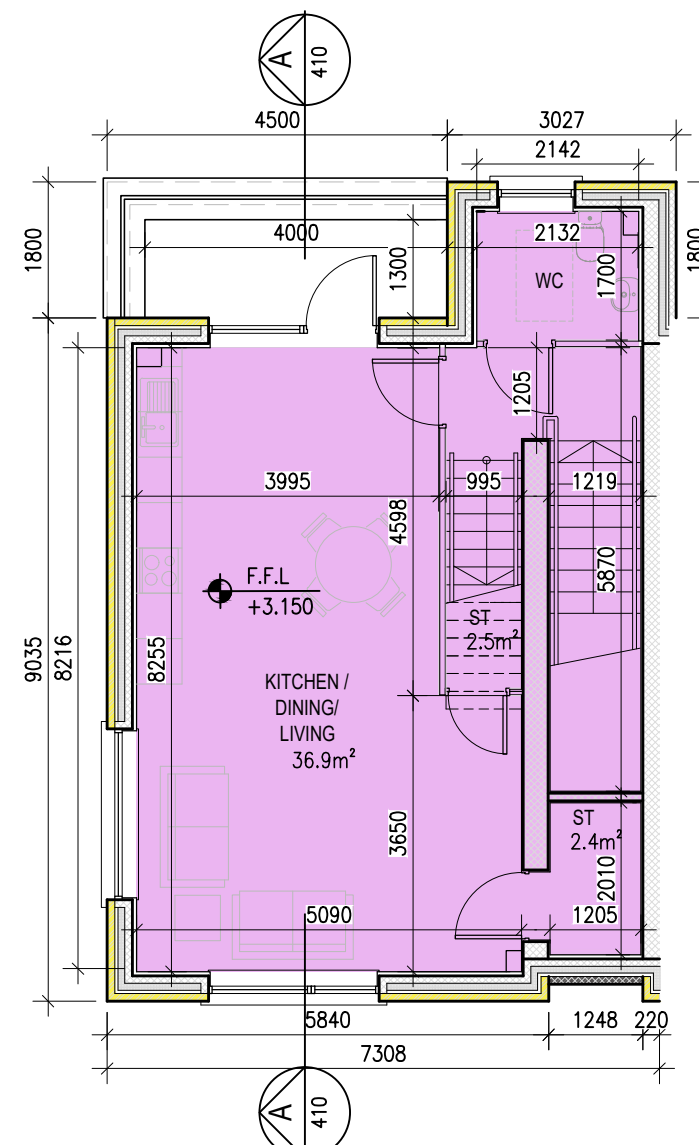

02 TYPE N - FIRST FLOOR PLAN
1:1000 A1

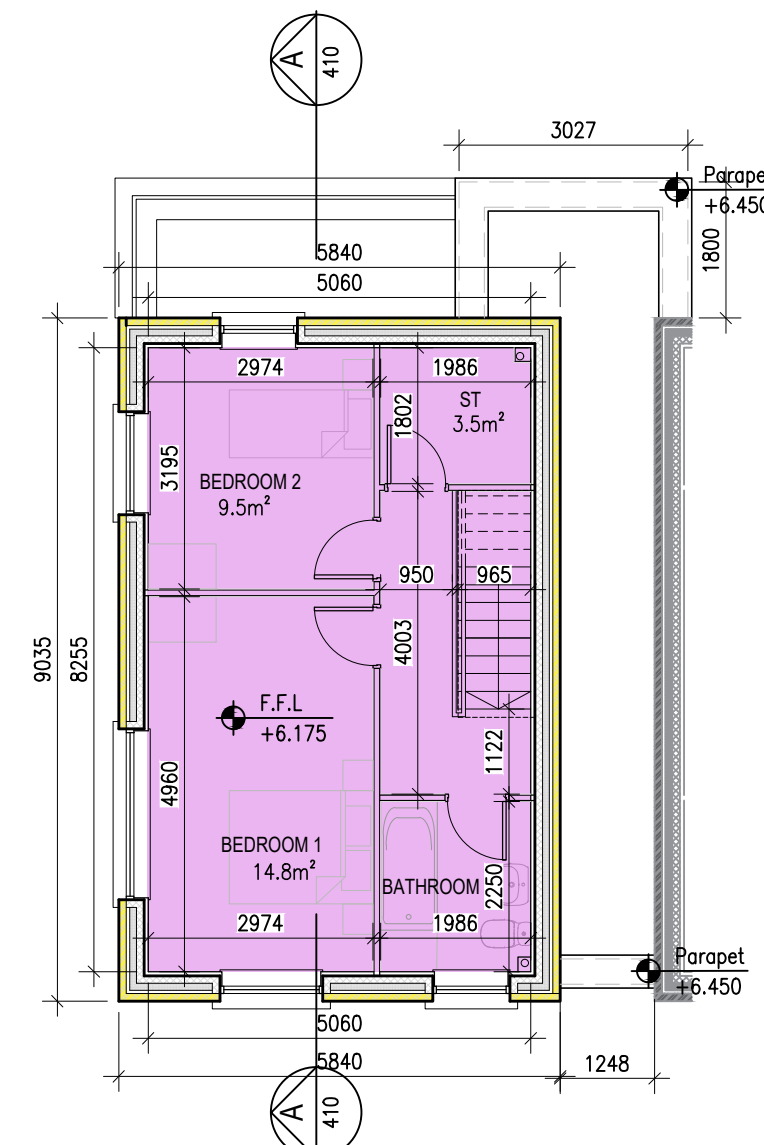

03 TYPE N - SECOND FLOOR PLAN
1:1000 A1

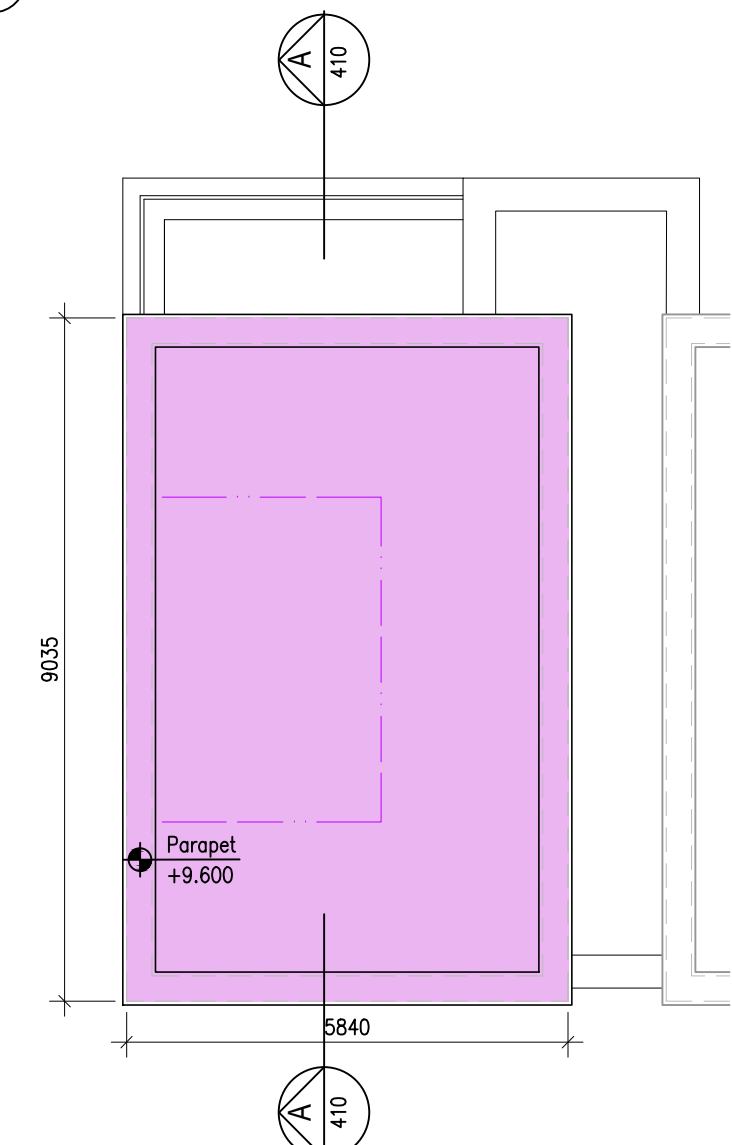

04 TYPE M/N - ROOF PLAN
1:1000 A1



05 TYPE M/N - FRONT ELEVATION
1:1000 A1



06 TYPE M/N - SIDE ELEVATION
1:1000 A1

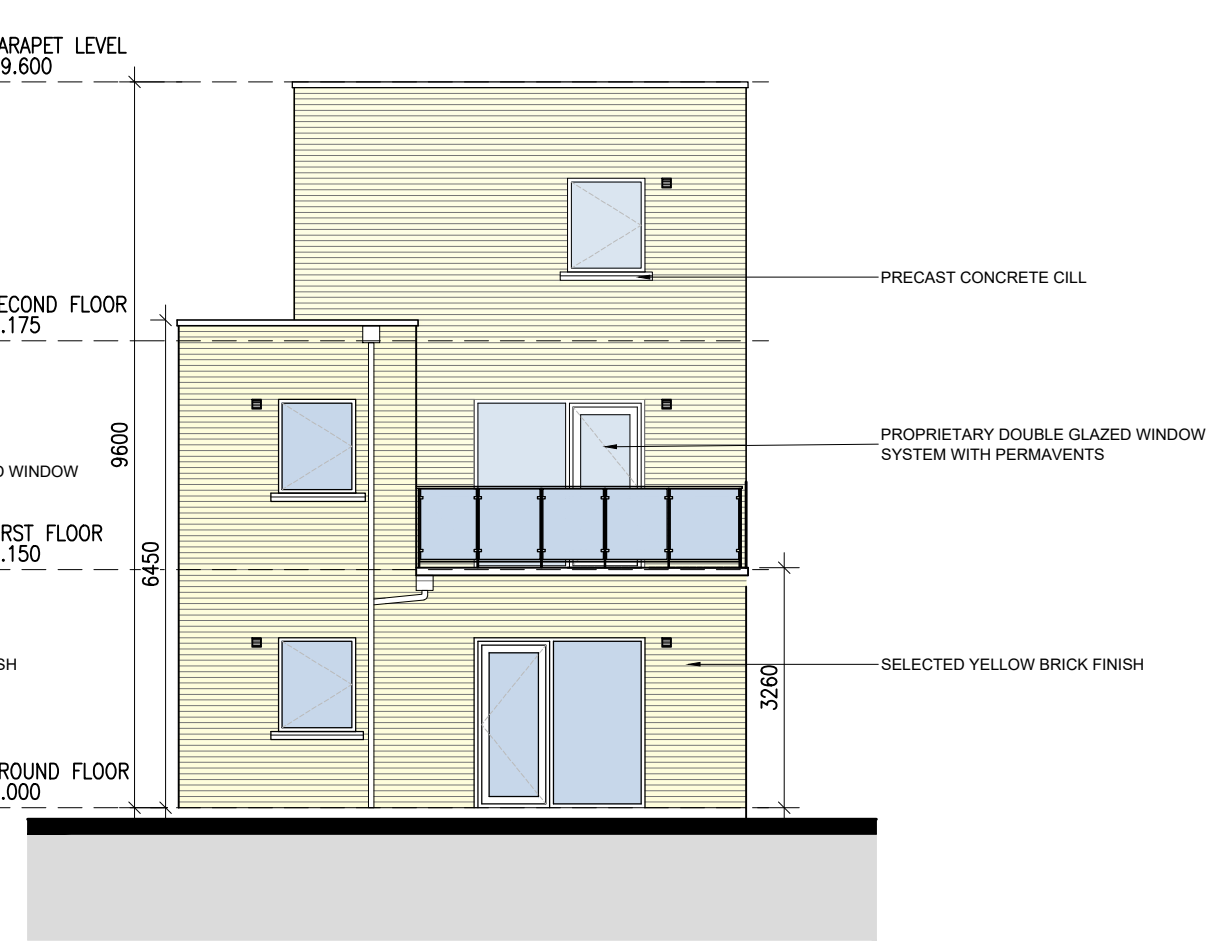

07 TYPE M/N - REAR ELEVATION
1:1000 A1

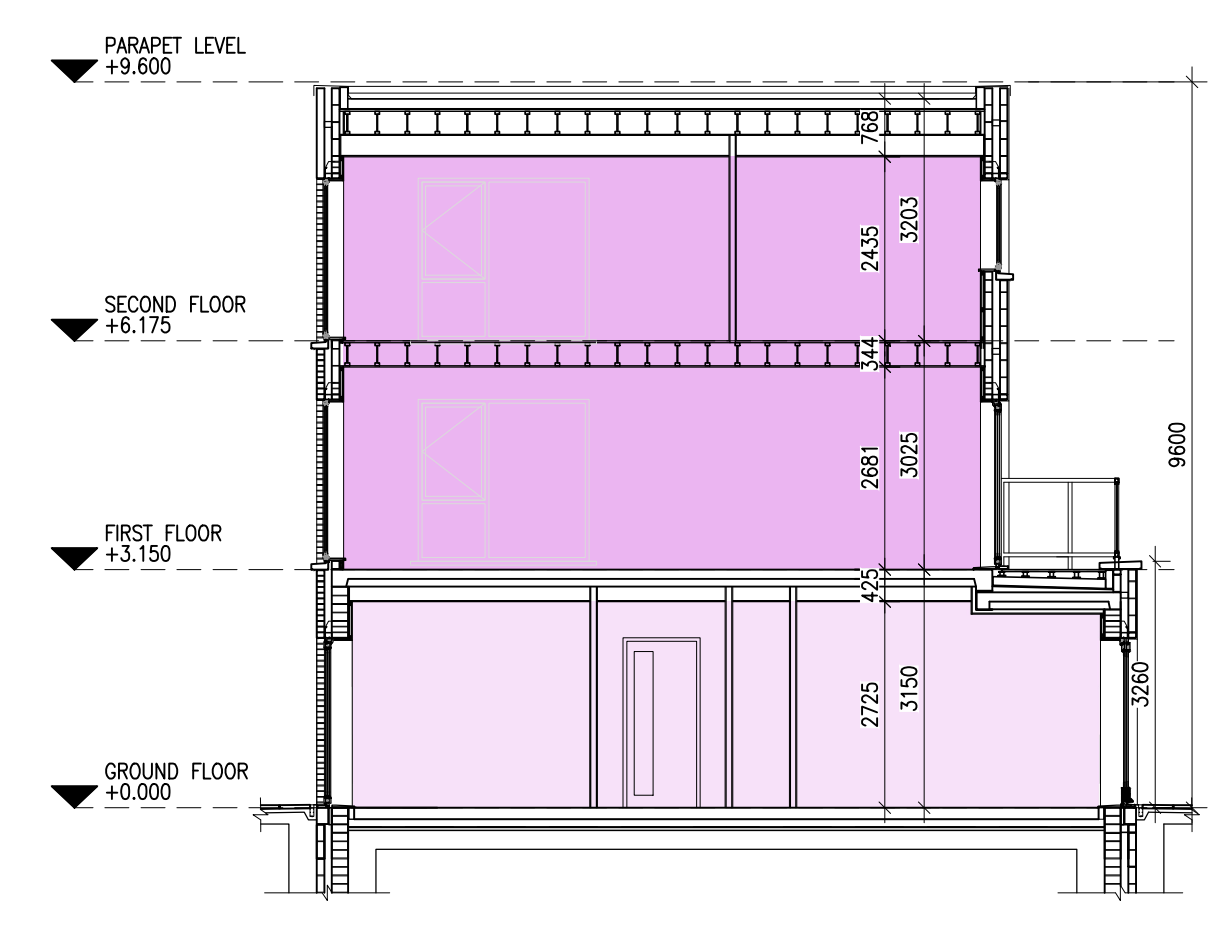

08 TYPE M/N - SECTION A-A
1:1000 A1

REFER ALSO TO SITE SETTING-OUT PLANS AND ELEVATIONS

Type	Description	Area			TOTAL AREA
		GROUND FLOOR	FIRST FLOOR	SECOND FLOOR	
M	1 BED - 2 PERSON APARTMENT	56m ²	N/A	N/A	56m ²
N	2 BED - 3 PERSON DUPLEX	5m ²	58m ²	42m ²	105m ²

OS DATUM - MALIN HEAD

Notes	Issue Status
1. Copyright Reserved	Progress
2. Work to agreed dimensions only. Do not scale drawings	Planning Application
3. The contractor is responsible for checking all levels and dimensions on site and shall refer all discrepancies to the Architect	Fire Cert
4. Where appropriate, for details of r.c. structure, or mechanical and electrical details, see Engineers drawings	Disability Cert
5. Proprietary items shall be fixed in strict accordance with manufacturers instructions.	Tender
6. Sizes of proprietary items shall be checked with manufacturer.	Construction
7. The contractor shall be responsible for the coordination of structure, finishes and services.	As Built
	Information Only

No.	Date	Revision	Initials
01	13/11/23	Draft Issue For Discussion	ED
02	23/11/23	Part B Issue	ED

Project: RESIDENTIAL DEVELOPMENT AT UPPER NANGOR ROAD, KILCARRBERY, CO. DUBLIN

Drawing Title: UNIT TYPE M/N - PLANS, ELEVATIONS & SECTION

Drawing No: 6168A-P-410

Scale: 1:100@A1 Rev: 02 Drawn: ED Date: 23/11/23

bkdarchitects
BURKE-KENNEDY DOYLE

6-7 HARDCOURT TERRACE, DUBLIN 2, IRELAND
T: +353-1-878 2400 F: +353-1-878 7385
www.bkd.ie



00 KEY PLAN
1:1000 A1

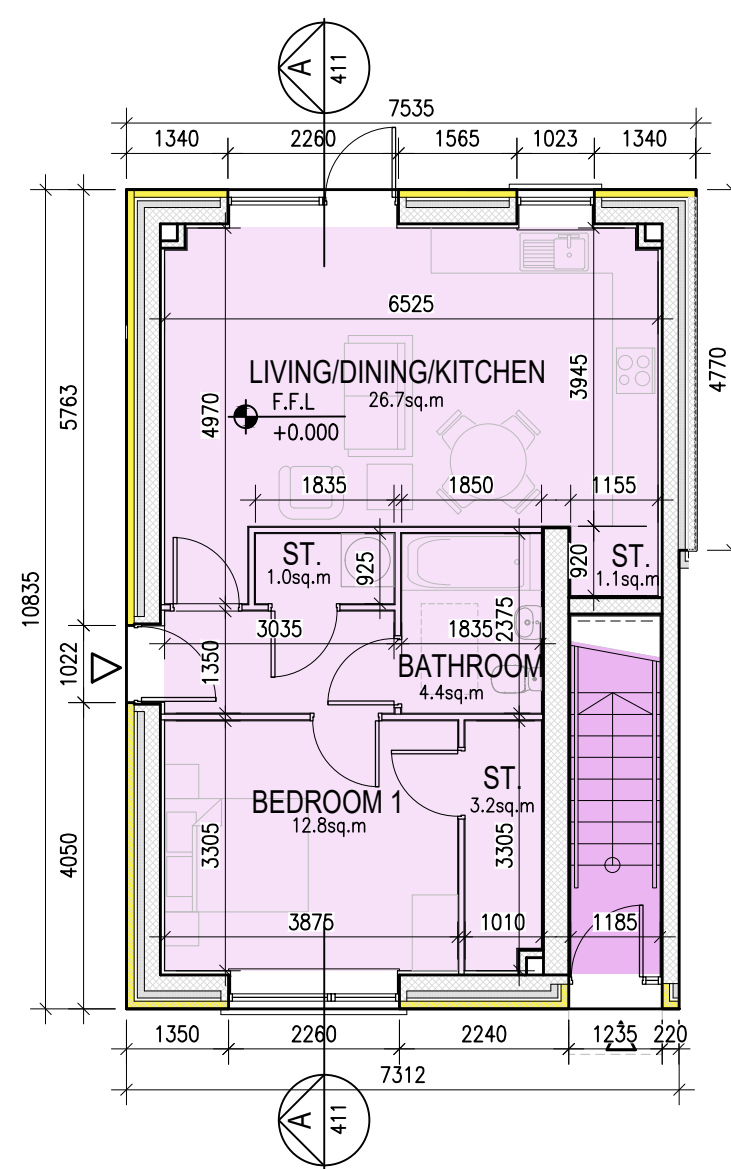

01 TYPE M1 - GROUND FLOOR PLAN
1:1000 A1

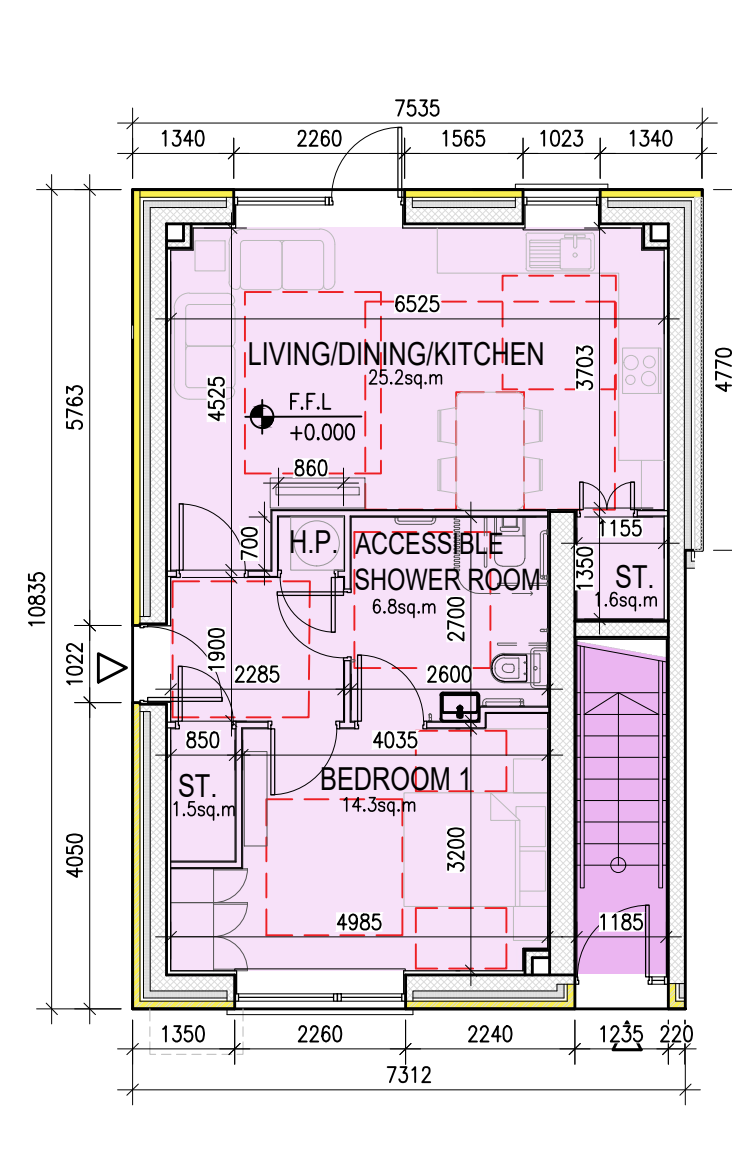

01UD TYPE M1 - (UNIVERSAL DESIGN UNIT) GROUND FLOOR PLAN
1:1000 A1

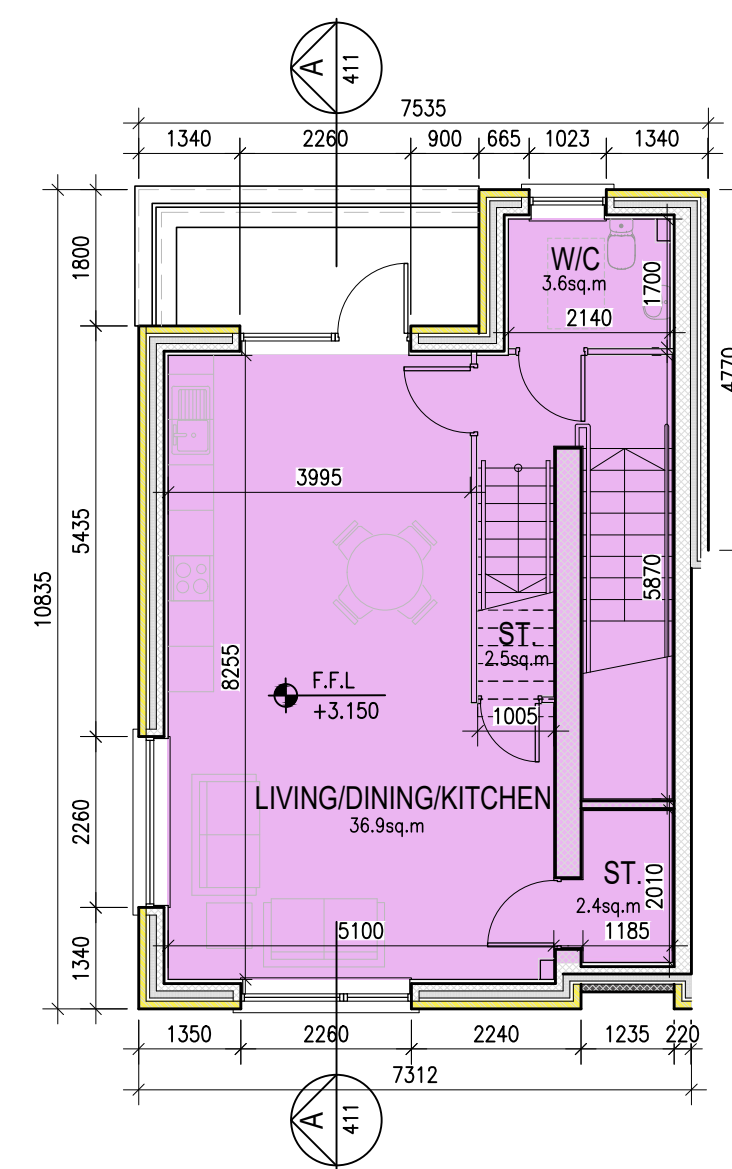

02 TYPE N1 - FIRST FLOOR PLAN
1:1000 A1

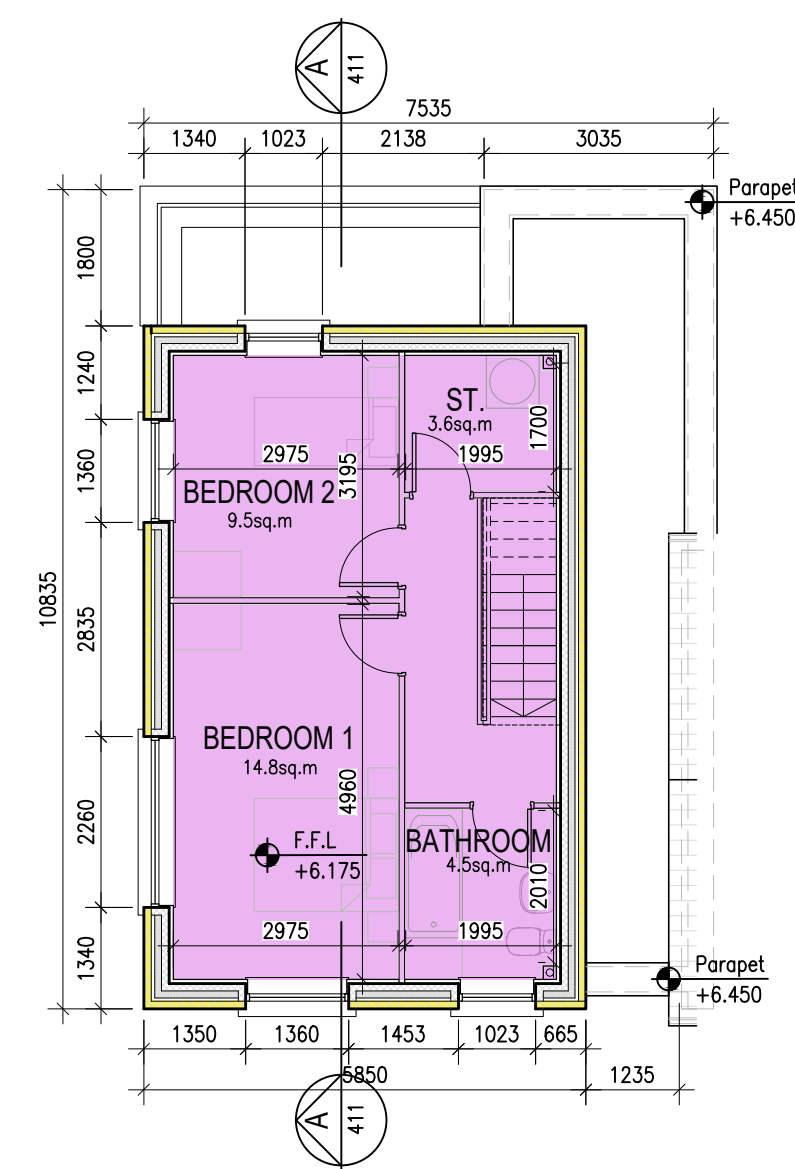

03 TYPE N1 - SECOND FLOOR PLAN
1:1000 A1

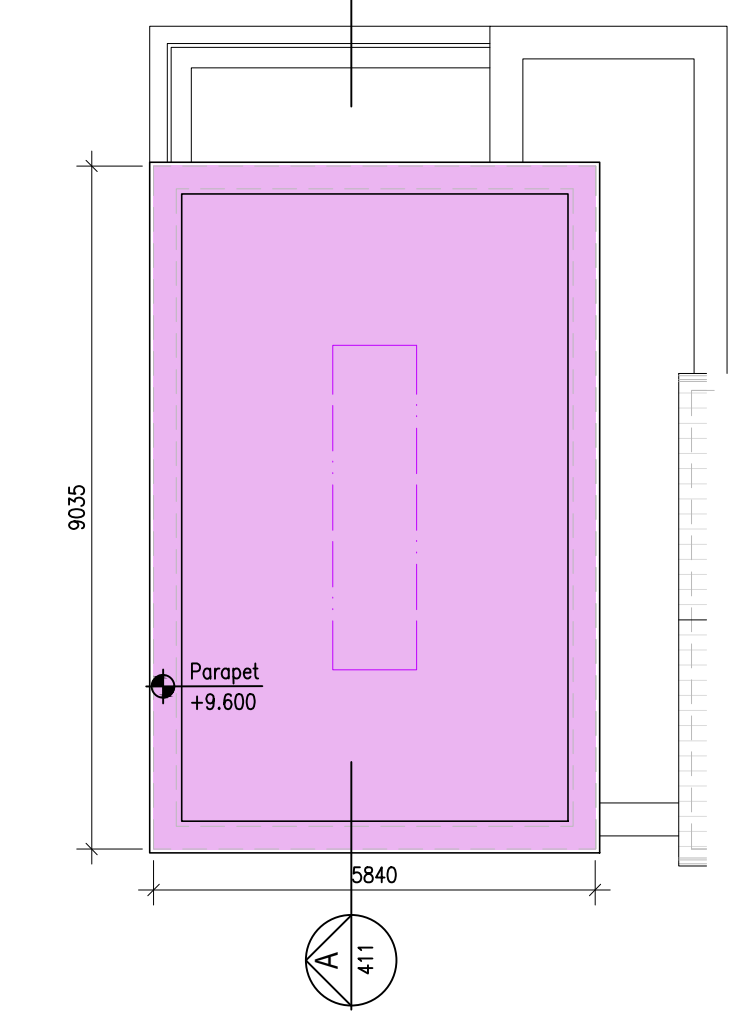

04 TYPE M1/N1 - ROOF PLAN
1:1000 A1

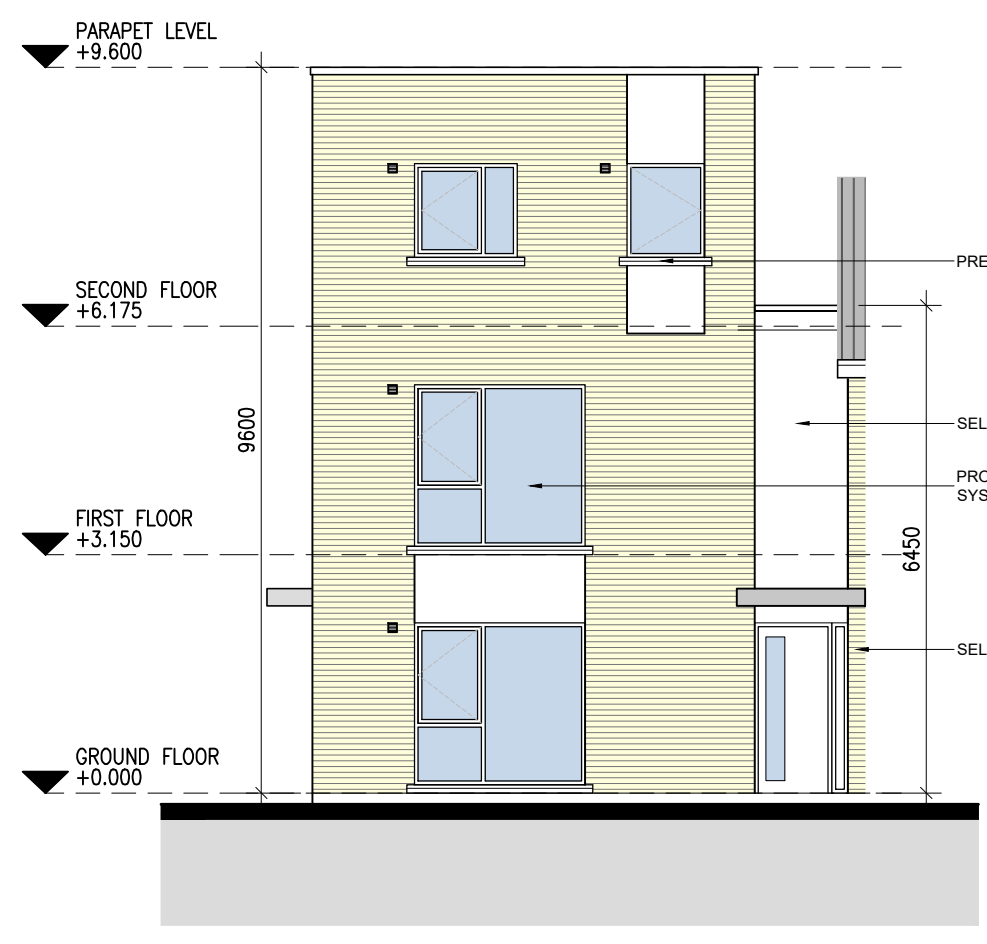

05 TYPE M1/N1 - FRONT ELEVATION
1:1000 A1



06 TYPE M1/N1 - SIDE ELEVATION
1:1000 A1

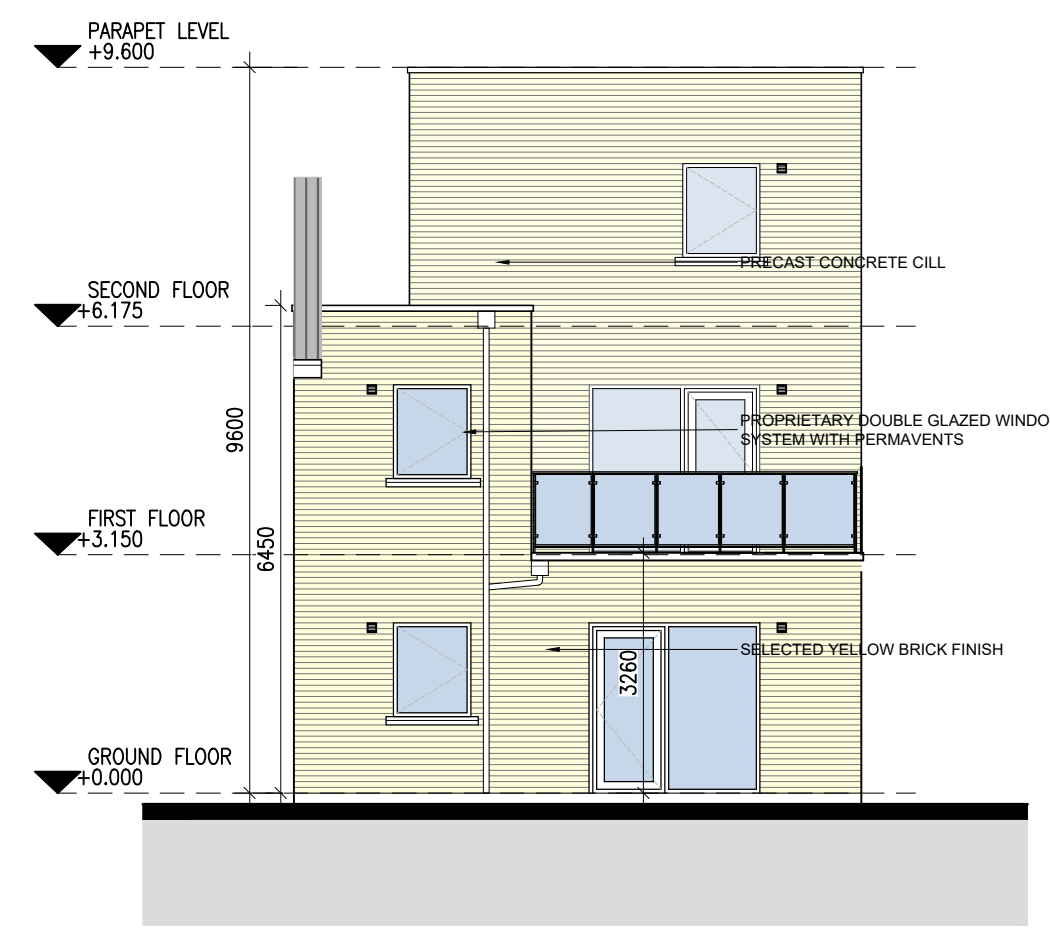

07 TYPE M1/N1 - REAR ELEVATION
1:1000 A1

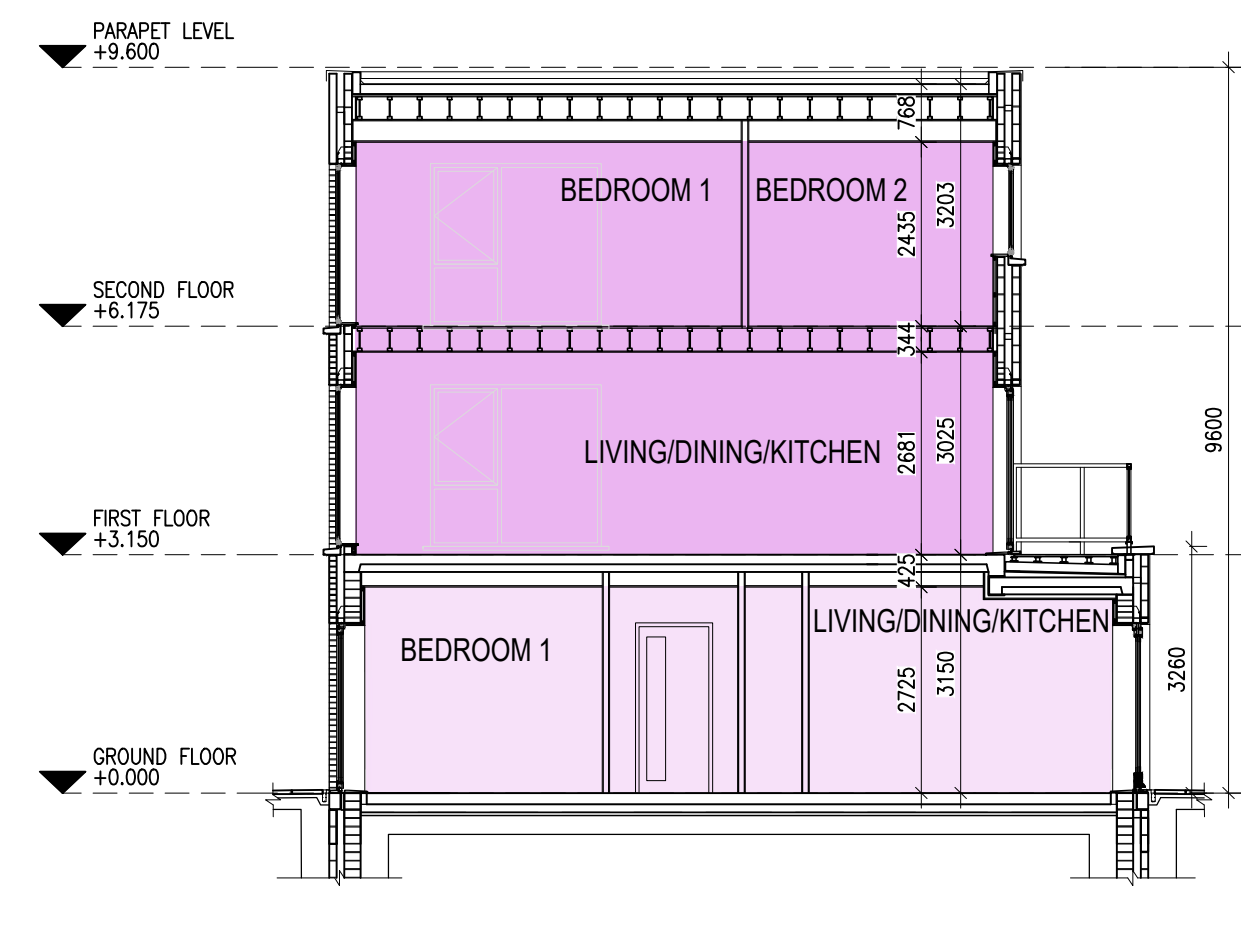

08 TYPE M1/N1 - SECTION A-A
1:1000 A1

REFER ALSO TO SITE SETTING-OUT PLANS AND ELEVATIONS

UNIT	DESCRIPTION	FLOOR LEVELS			TOTAL AREA
		GROUND FLOOR	FIRST FLOOR	SECOND FLOOR	
M1	1 BED - 2 PERSON APARTMENT	56m ²	N/A	N/A	56m ²
N1	2 BED - 3 PERSON DUPLEX	5m ²	58m ²	42m ²	105m ²

OS DATUM - MALIN HEAD

Notes	Issue Status
1. Copyright Reserved	Progress
2. Work to agreed dimensions only. Do not scale drawing	Planning Application
3. The contractor is responsible for checking all levels and dimensions on site and shall refer all discrepancies to the Architect	Fire Cert
4. Where appropriate, for details of r.c. structure, or mechanical and electrical details, see Engineers drawings	Disability Cert
5. Proprietary items shall be fixed in strict accordance with manufacturers instructions.	Tender
6. Sizes of proprietary items shall be checked with manufacturer.	Construction
7. The contractor shall be responsible for the coordination of structure, finishes and services.	As Built
	Information Only

No.	Date	Revision	Initials
01	11/10/23	WORK IN PROGRESS ISSUE	ED
02	13/11/23	Draft Issue For Discussion	ED
03	23/11/23	Part 8 Issue	ED

Project: RESIDENTIAL DEVELOPMENT AT UPPER NANGOR ROAD, KILCAREBERRY, CO. DUBLIN

Drawing Title: UNIT TYPE M1/N1 - PLANS, ELEVATIONS & SECTION

Drawing No: 6168A-P-411

Scale: 1:100@A1 Rev: 03 Drawn: ED Date: 23/11/23

bkdarchitects
BURKE-KENNEDY DOYLE

6-7 HARDCOURT TERRACE, DUBLIN 2, IRELAND
T: +353-1-878 2400 F: +353-1-878 7385
www.bkd.ie



00 KEY PLAN
1:1000 A1

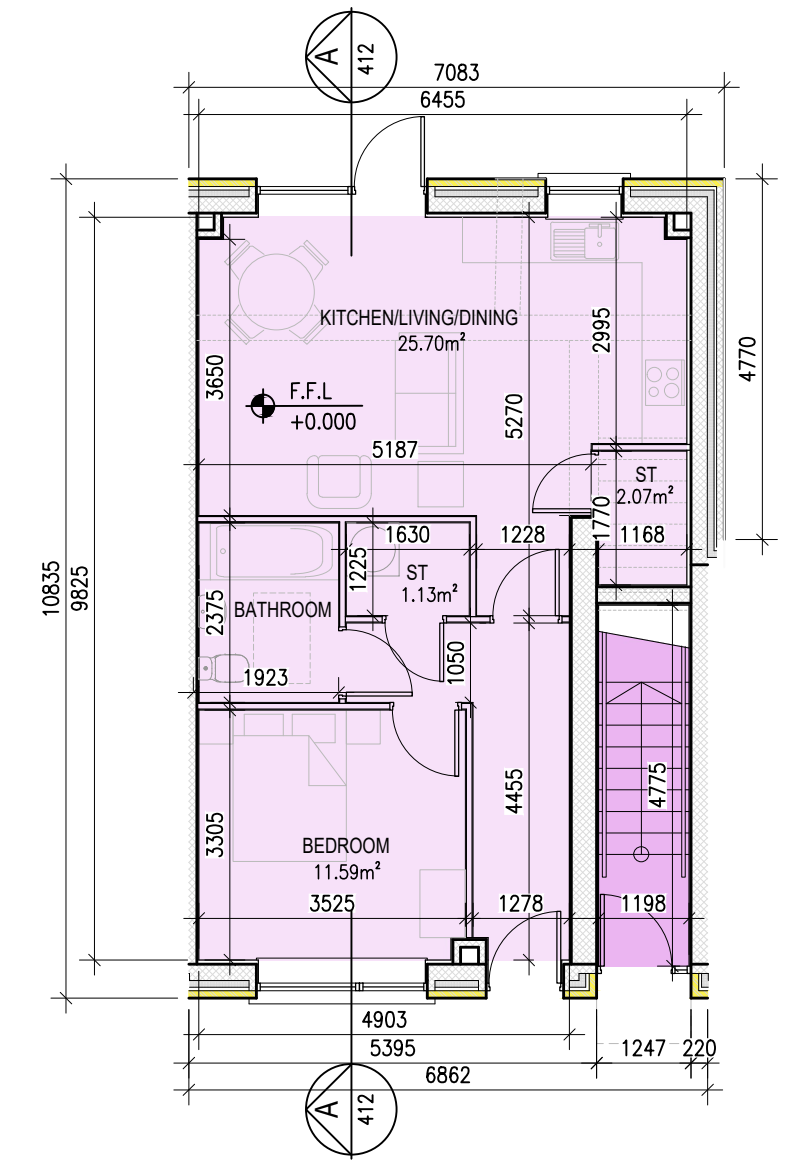
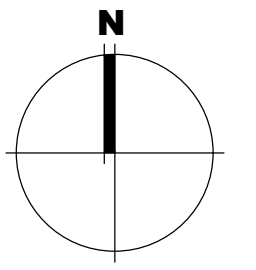

01 TYPE M2 - GROUND FLOOR PLAN
1:1000 A1

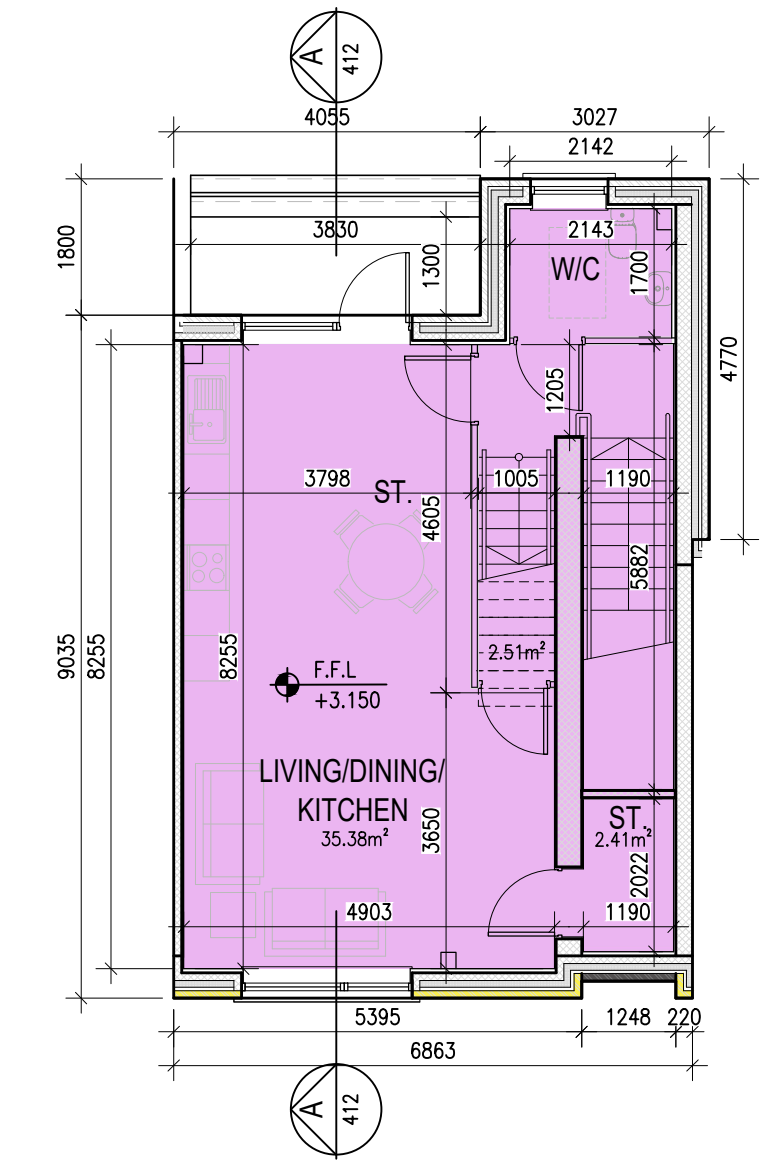

02 TYPE N2 - FIRST FLOOR PLAN
1:1000 A1

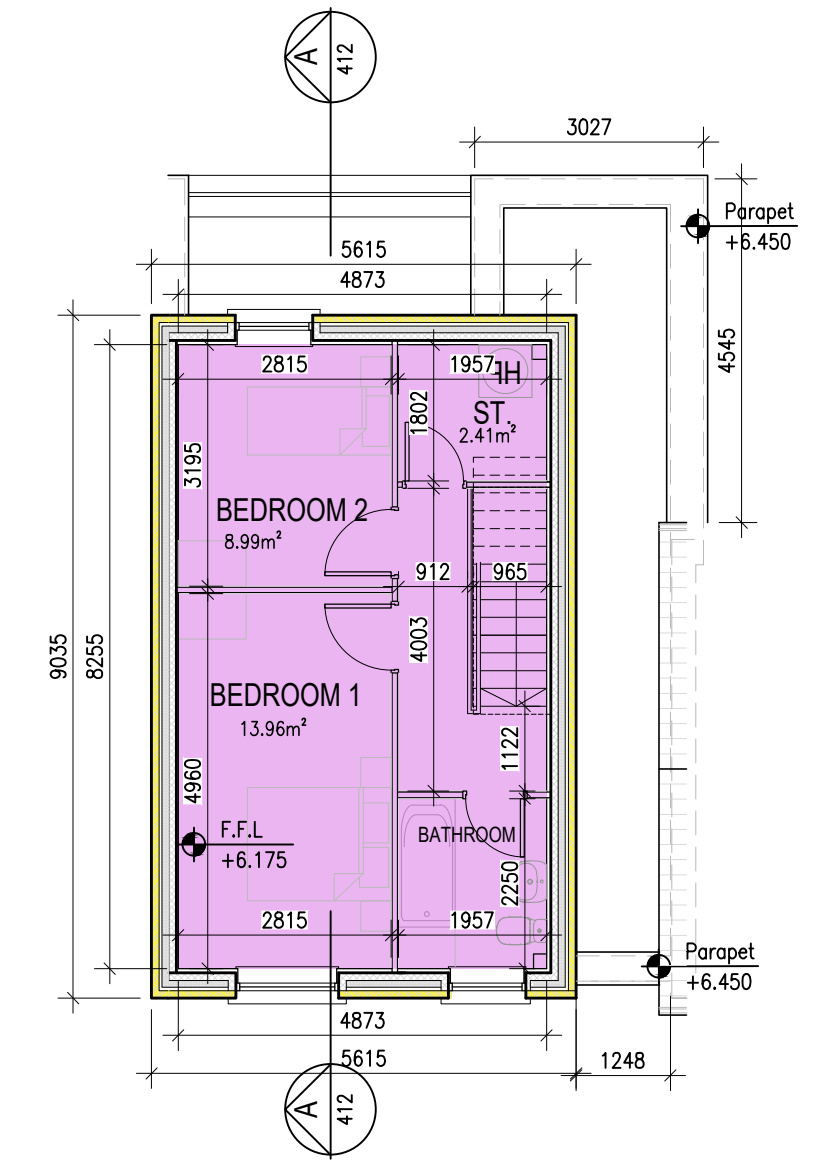

03 TYPE N2 - SECOND FLOOR PLAN
1:1000 A1

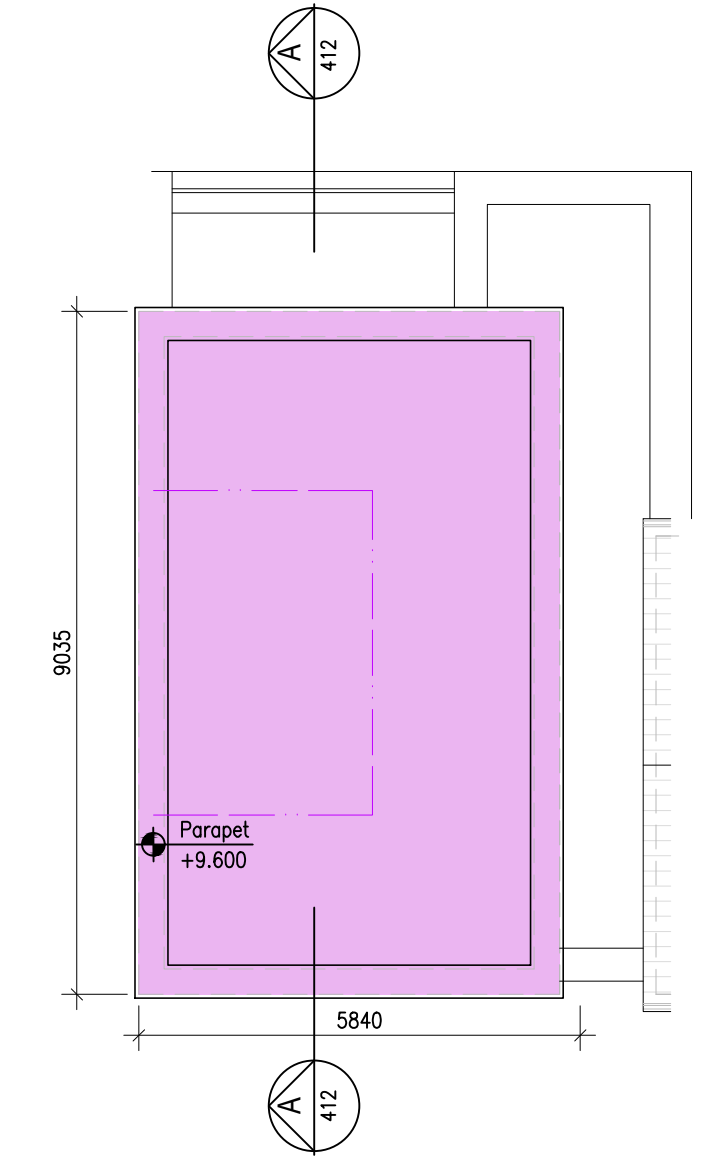

04 TYPE M2/ N2 - ROOF PLAN
1:1000 A1

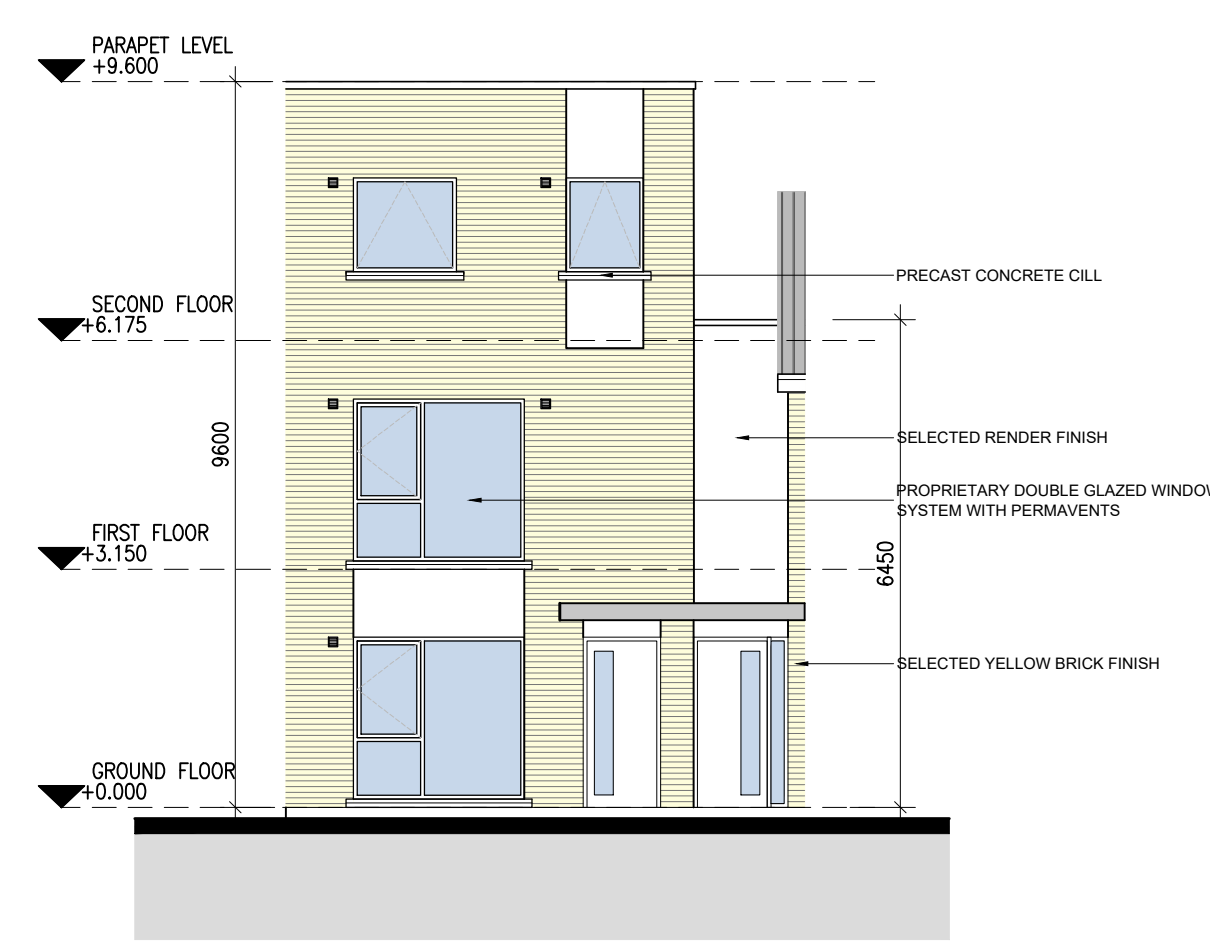

05 TYPE M2/ N2 - FRONT ELEVATION
1:1000 A1

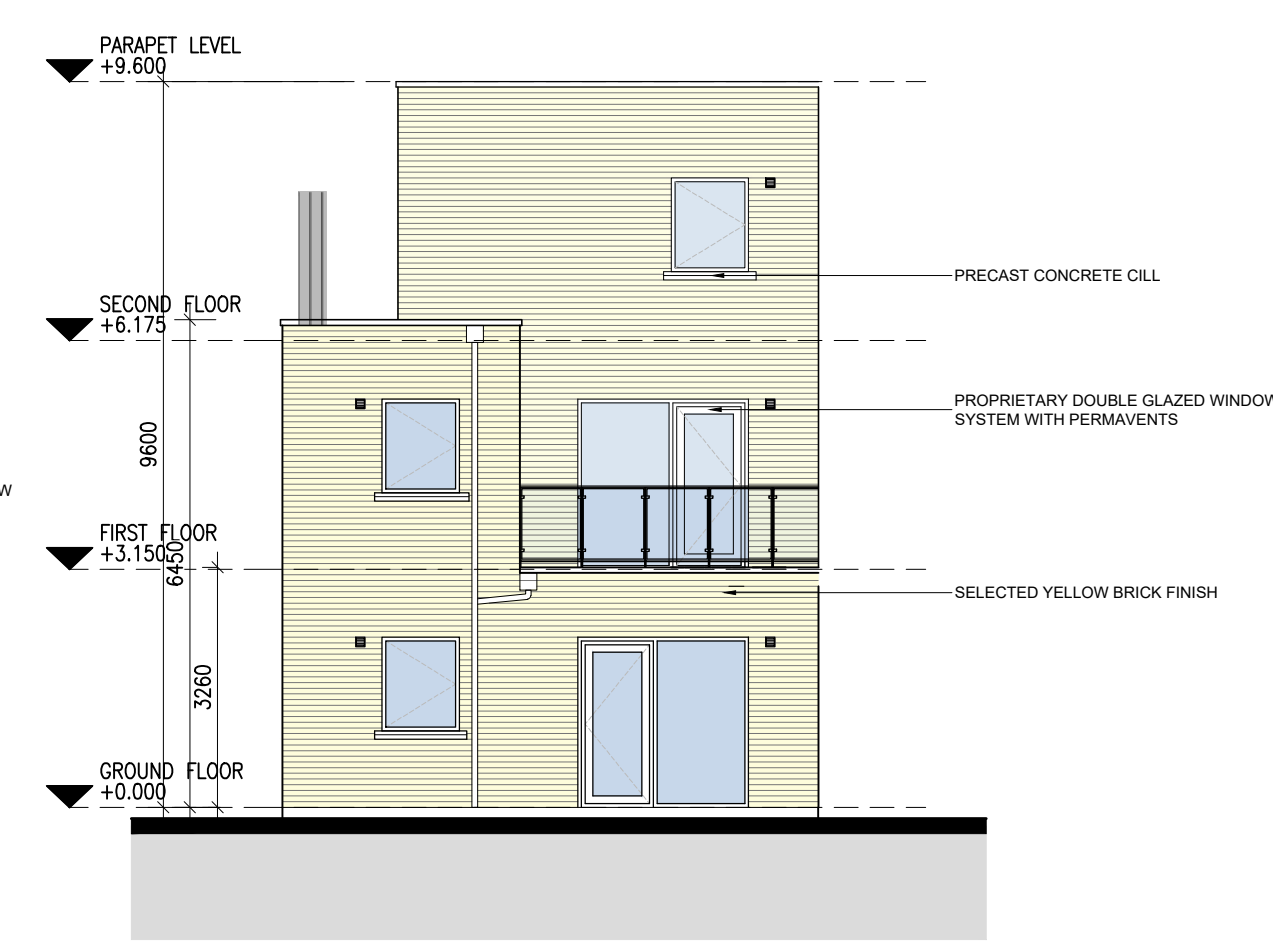

06 TYPE M2/ N2 - REAR ELEVATION
1:1000 A1

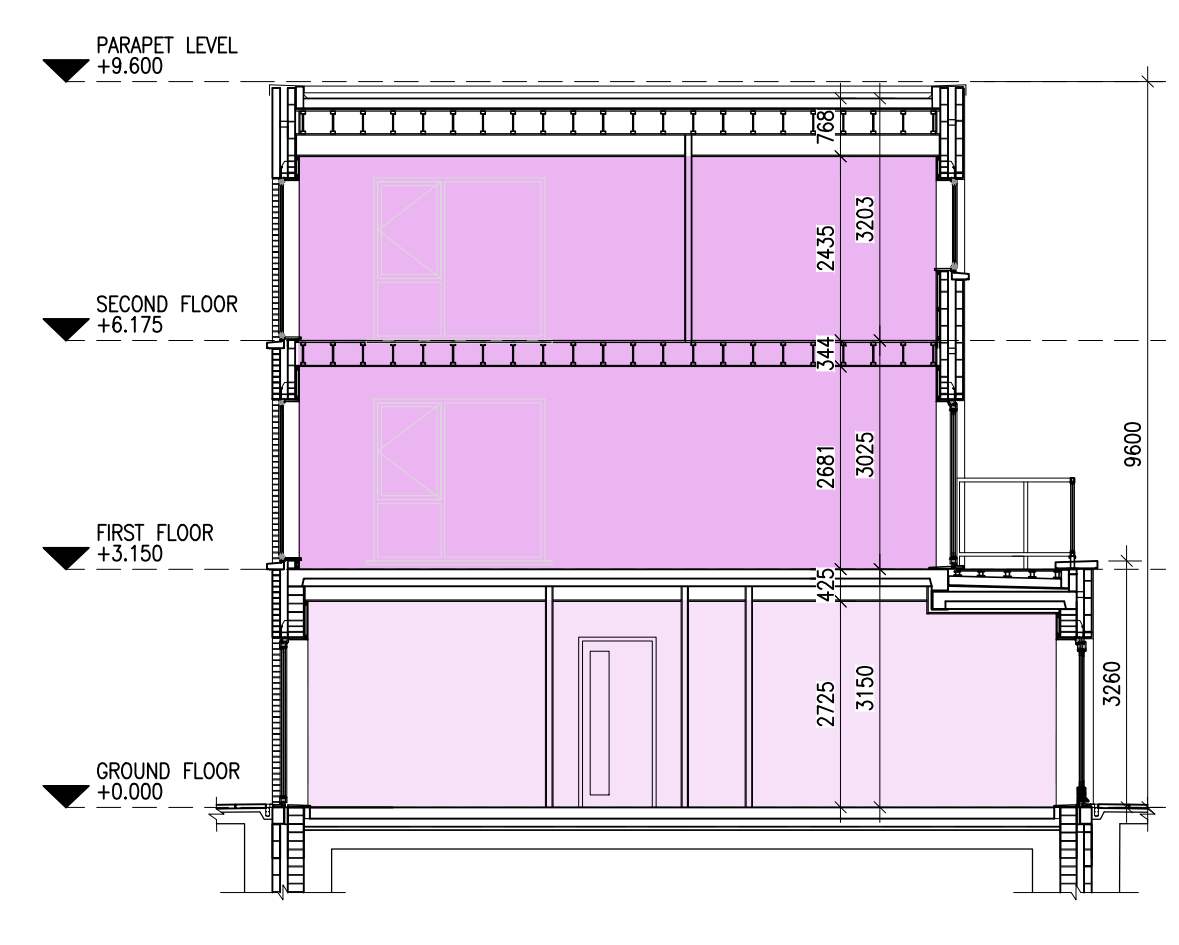

07 TYPE M2/ N2 - SECTION A-A
1:1000 A1

REFER ALSO TO SITE SETTING-OUT PLANS AND ELEVATIONS

UNIT TYPE	DESCRIPTION	FLOOR AREA			TOTAL AREA
		GROUND FLOOR	FIRST FLOOR	SECOND FLOOR	
M2	1 BED - 2 PERSON APARTMENT	55m ²	N/A	N/A	55m ²
N2	2 BED - 3 PERSON DUPLEX	5m ²	56m ²	41m ²	102m ²

OS DATUM - MALIN HEAD

Notes	Issue Status
1. Copyright Reserved	Progress
2. Work to agreed dimensions only. Do not scale drawing	Planning Application
3. The contractor is responsible for checking all levels and dimensions on site and shall refer all discrepancies to the Architect	Fire Cert
4. Where appropriate, for details of r.c. structure, or mechanical and electrical details, see Engineers drawings	Disability Cert
5. Proprietary items shall be fixed in strict accordance with manufacturers instructions.	Tender
6. Sizes of proprietary items shall be checked with manufacturer.	Construction
7. The contractor shall be responsible for the coordination of structure, finishes and services.	As Built
	Information Only

No.	Date	Revision	Initials
01	13/11/23	Draft Issue For Discussion	ED
02	23/11/23	Part 8 Issue	ED

Project: RESIDENTIAL DEVELOPMENT AT UPPER NANGOR ROAD, KILCAREBY, CO. DUBLIN

Drawing Title: UNIT TYPE M2/N2 - PLANS, ELEVATIONS & SECTION

Drawing No: 6168A-P-412

Scale: 1:100@A1 Rev: 02 Drawn: ED Date: 23/11/23

bkdarchitects
BURKE-KENNEDY DOYLE

6-7 HARDCOURT TERRACE, DUBLIN 2, IRELAND
t: +353-1-878 2400 f: +353-1-878 7395
www.bkd.ie

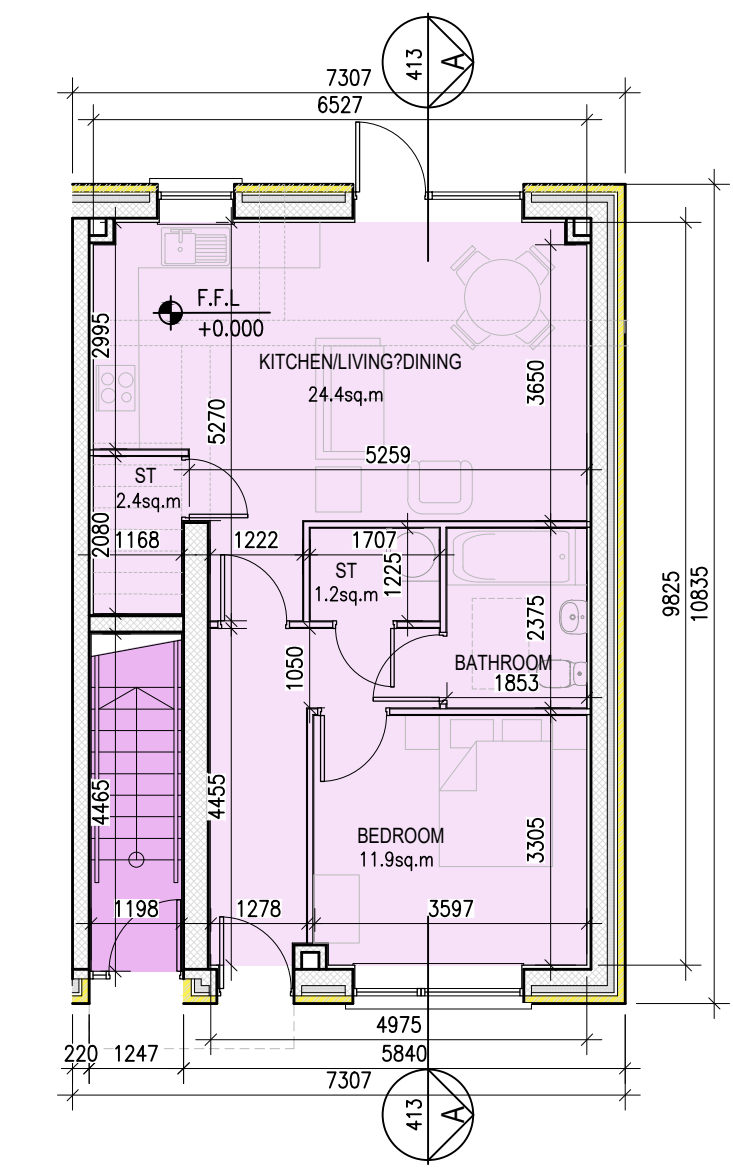

01 TYPE M3 - GROUND FLOOR PLAN
1:1000 A1

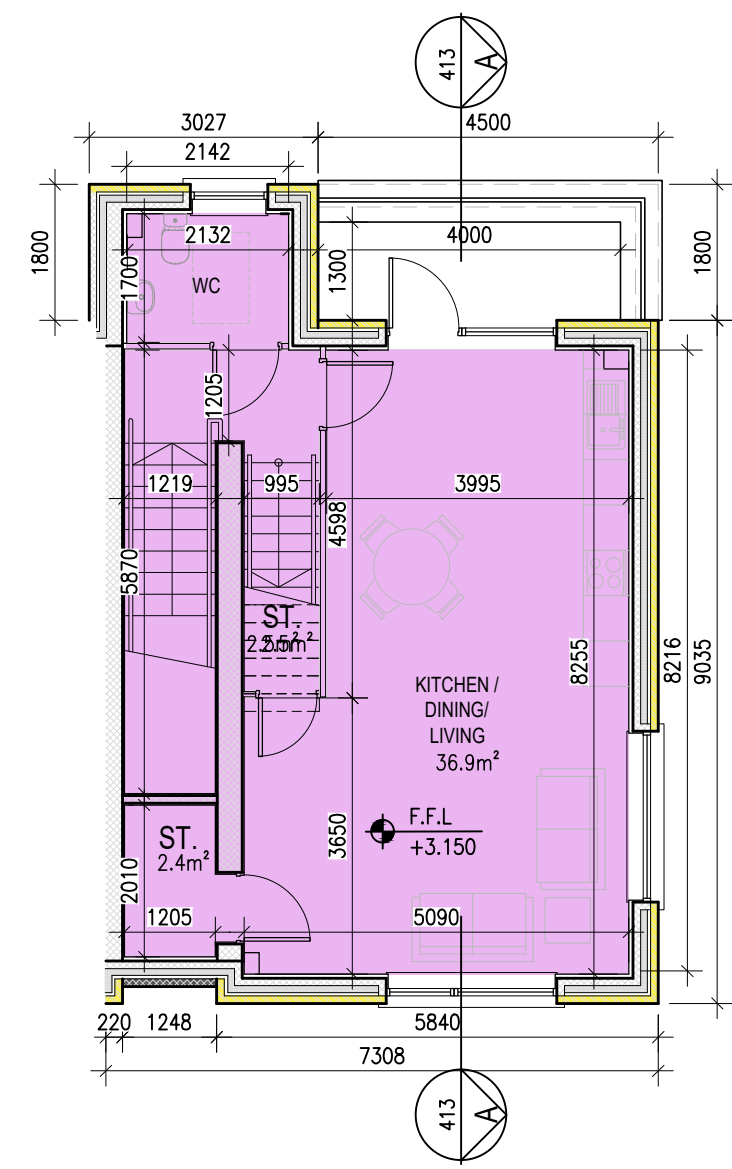

02 TYPE N3 - FIRST FLOOR PLAN
1:1000 A1

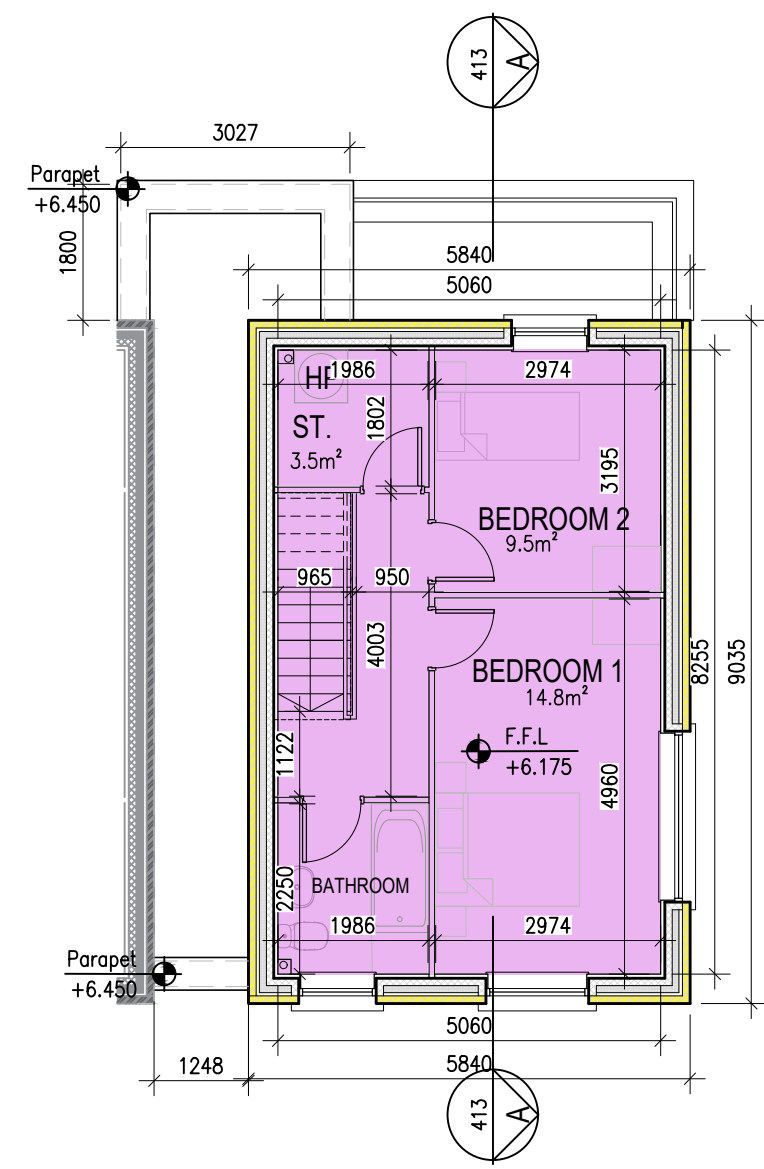

03 TYPE N3 - SECOND FLOOR PLAN
1:1000 A1

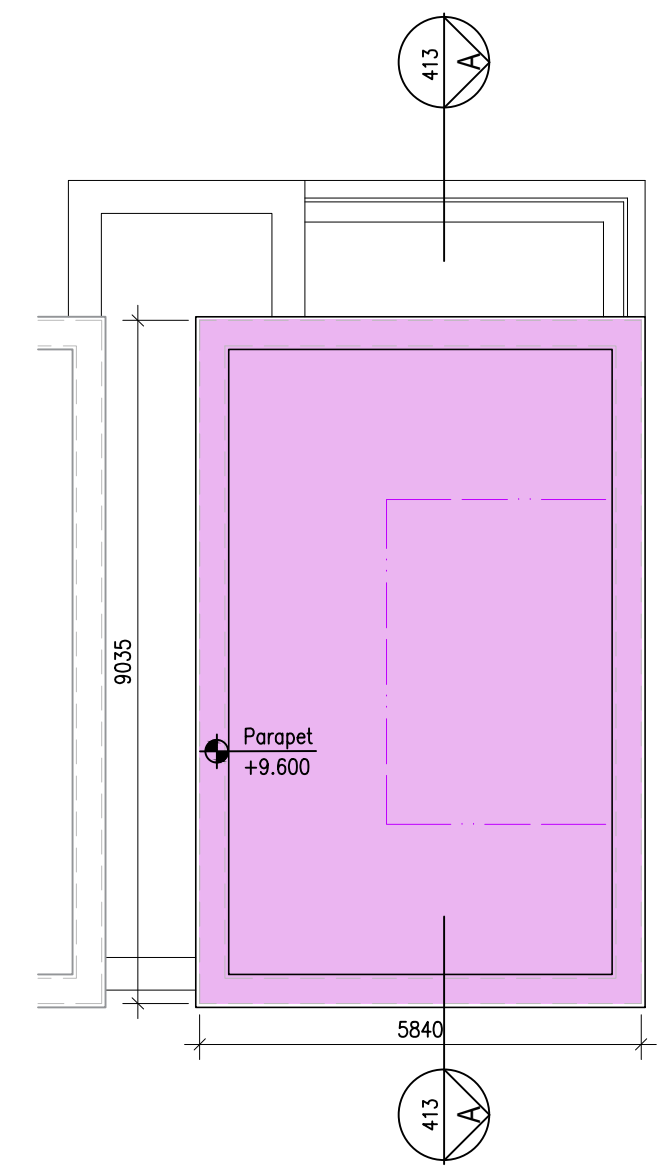

04 TYPE M3/ N3 - ROOF PLAN
1:1000 A1



05 TYPE M3/ N3 - FRONT ELEVATION
1:1000 A1



06 TYPE M3/ N3 - SIDE ELEVATION
1:1000 A1

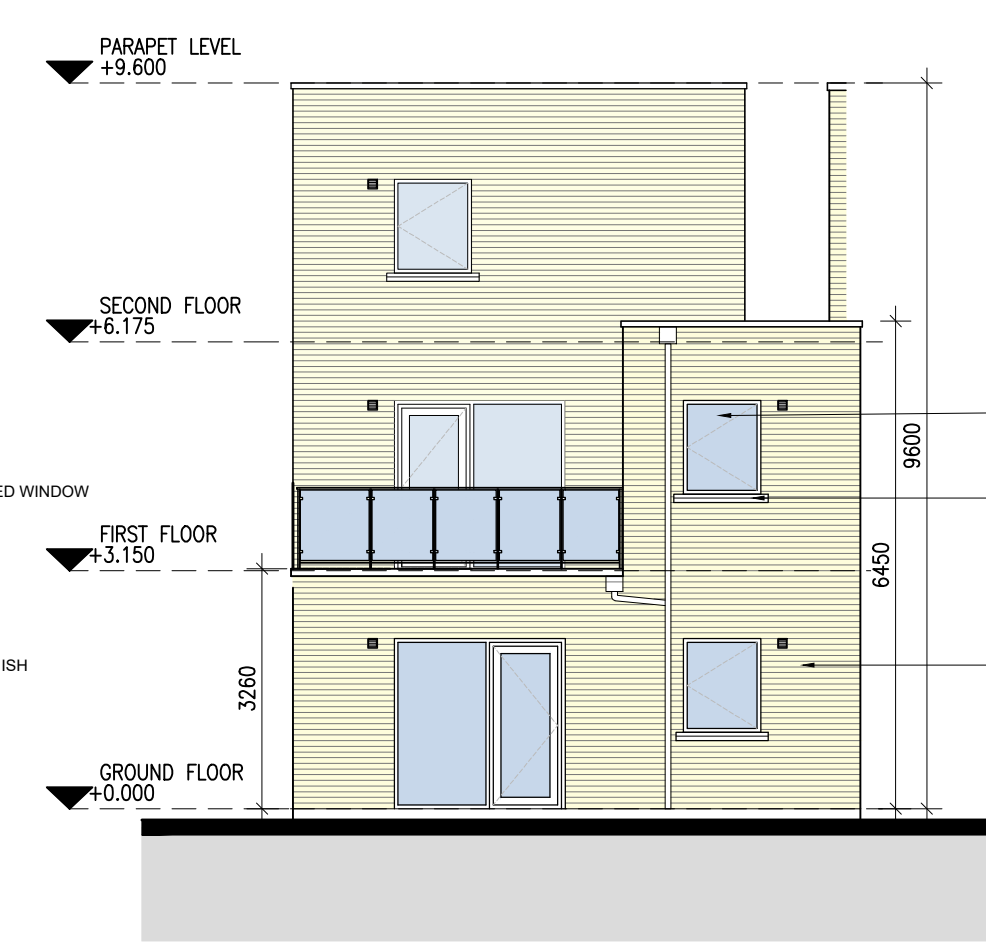

07 TYPE M3/ N3 - REAR ELEVATION
1:1000 A1

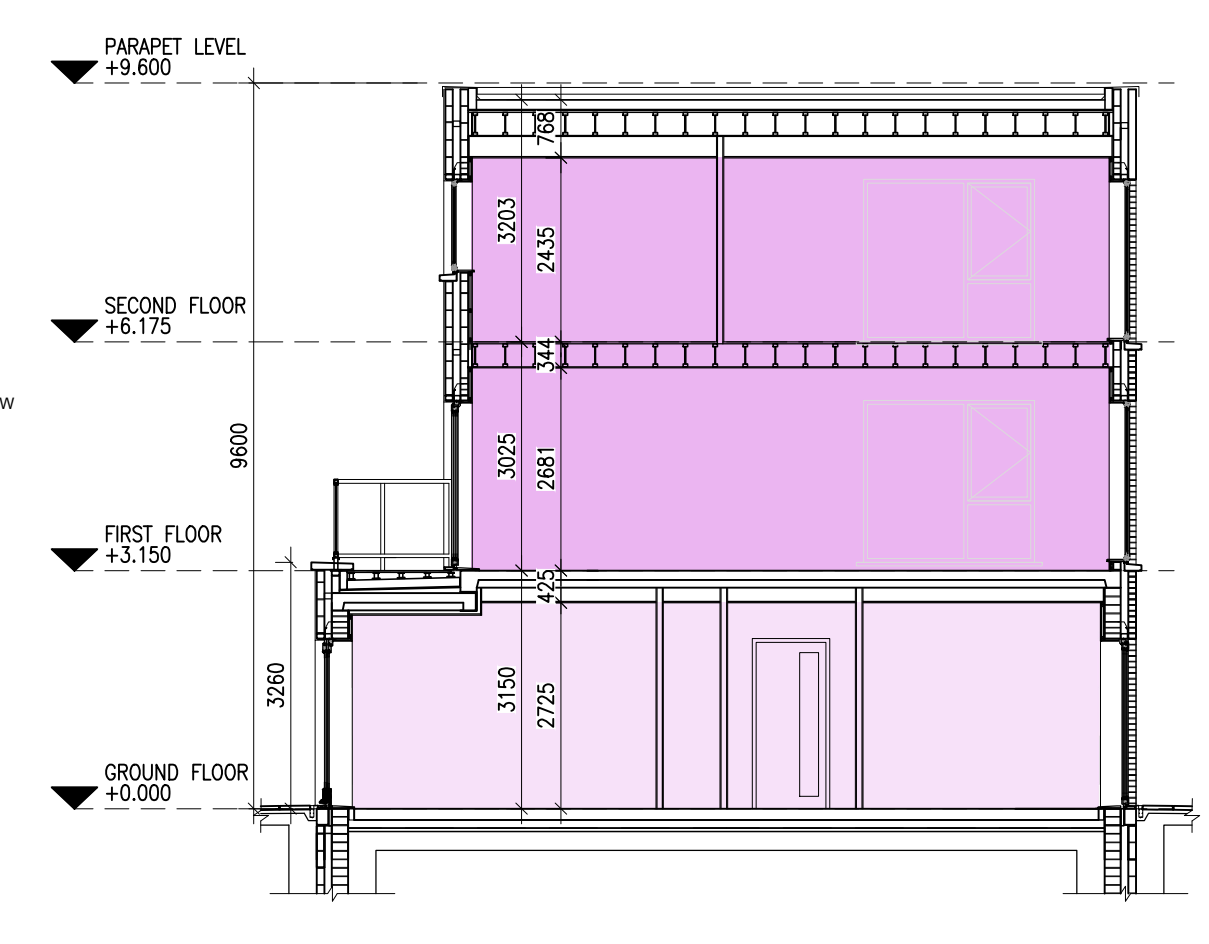

08 TYPE M3/ N3 - SECTION A-A
1:1000 A1

REFER ALSO TO SITE SETTING-OUT PLANS AND ELEVATIONS

Type	Description	Area			TOTAL AREA
		GROUND FLOOR	FIRST FLOOR	SECOND FLOOR	
M3	1 BED - 2 PERSON APARTMENT	56m ²	N/A	N/A	56m ²
N3	2 BED - 3 PERSON DUPLEX	5m ²	58m ²	42m ²	105m ²

OS DATUM - MALIN HEAD

Notes	Issue Status
1. Copyright Reserved	Progress
2. Work to agreed dimensions only. Do not scale drawings	Planning Application
3. The contractor is responsible for checking all levels and dimensions on site and shall refer all discrepancies to the Architect	Fire Cert
4. Where appropriate, for details of r.c. structure, or mechanical and electrical details, see Engineers drawings	Disability Cert
5. Proprietary items shall be fixed in strict accordance with manufacturers instructions.	Tender
6. Sizes of proprietary items shall be checked with manufacturer.	Construction
7. The contractor shall be responsible for the coordination of structure, finishes and services.	As Built
	Information Only

No.	Date	Revision	Initials
01	07/11/23	Draft Issue For Discussion	ED
02	23/11/23	Part B Issue	ED

Project: RESIDENTIAL DEVELOPMENT AT UPPER NANGOR ROAD, KILCARBERY, CO. DUBLIN

6-7 HARDCOURT TERRACE, DUBLIN 2, IRELAND
 T: +353-1-878 2400 F: +353-1-878 7395
 www.bkd.ie

Drawing Title: HOUSE TYPE M3/N3 - PLANS, ELEVATIONS & SECTION

Drawing No: 6168A-P-413

Scale: 1:100@A1 Rev: 02 Drawn: ED Date: 23/11/23

bkdarchitects
BURKE-KENNEDY DOYLE

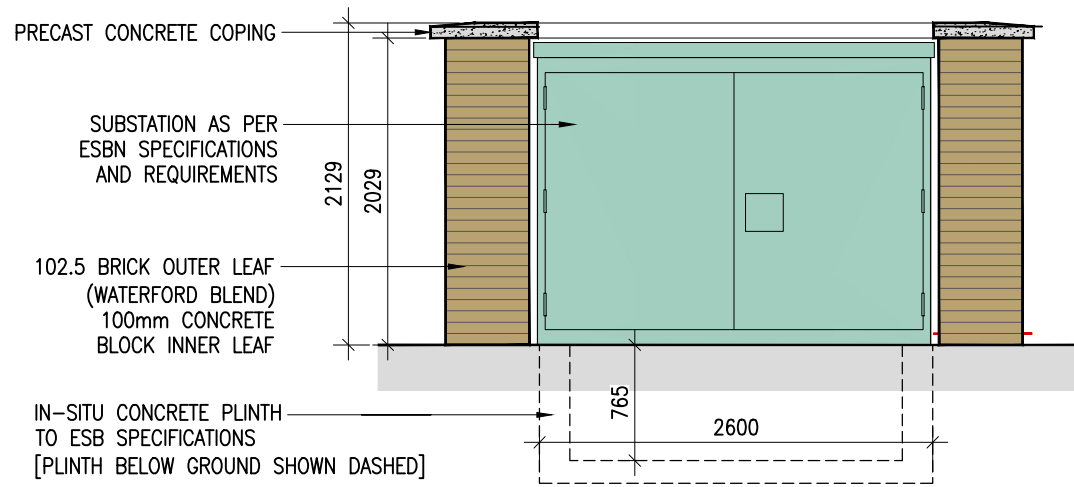

1 ESB Substation - Front Elevation

P-500 1:50@A3

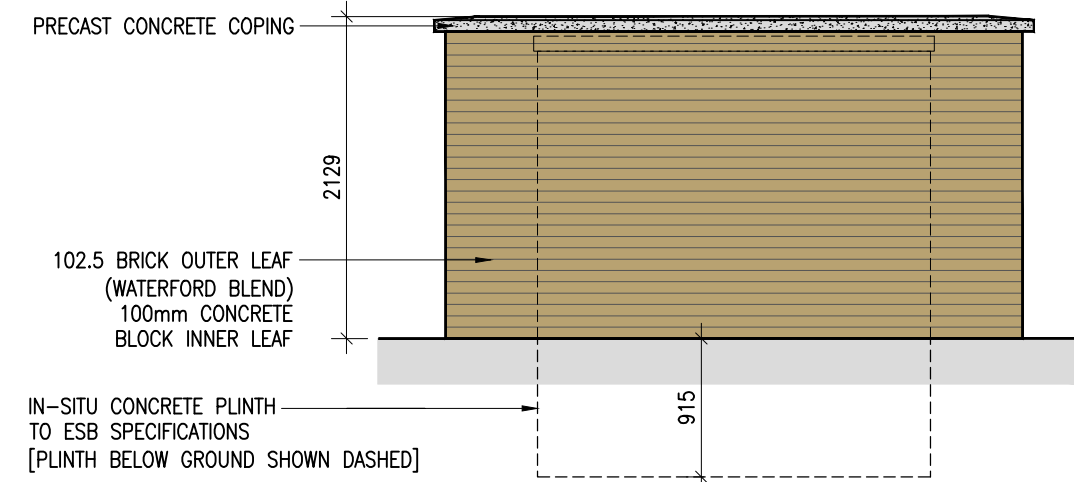

2 ESB Substation - Rear Elevation

P-500 1:50@A3

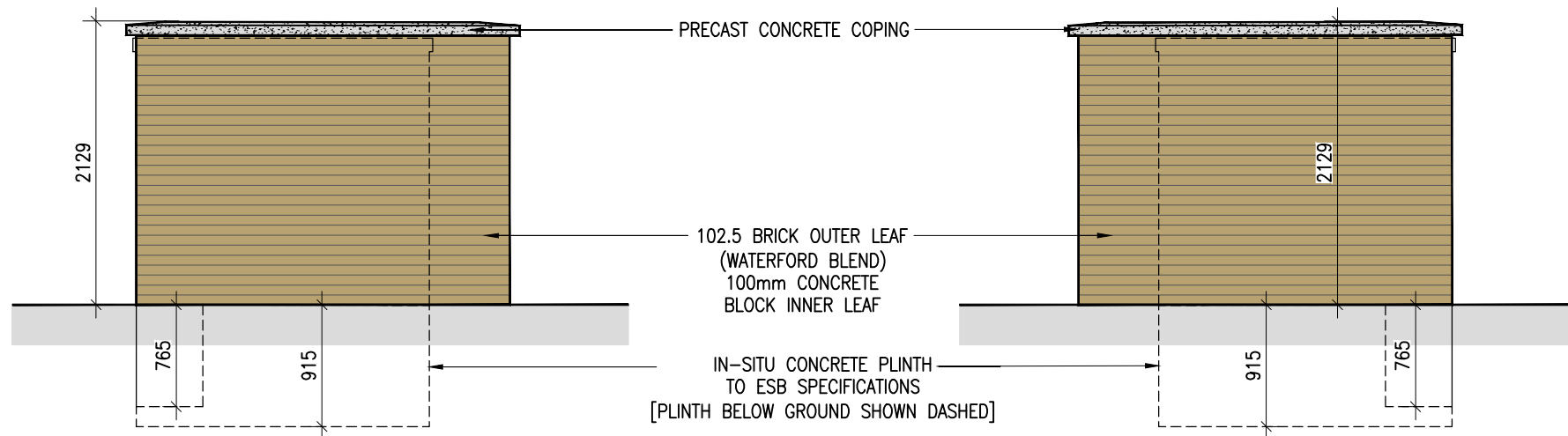

3 ESB Substation - Side Elevations

P-500 1:50@A3

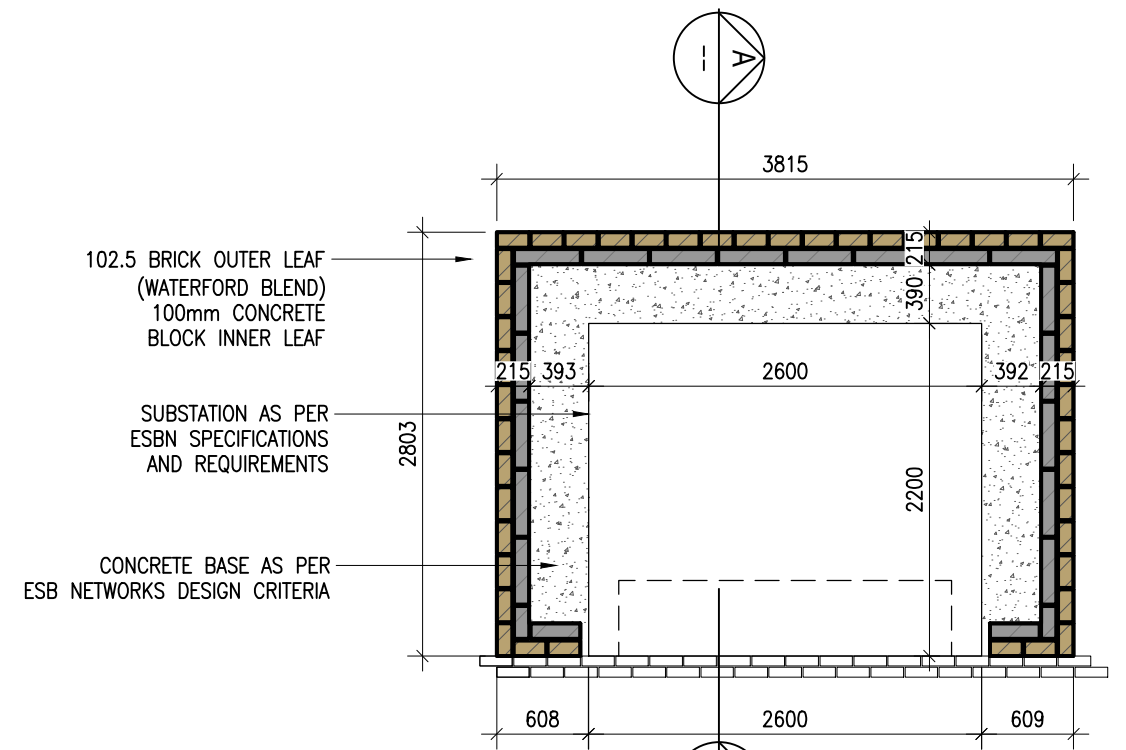

4 ESB Substation - Plan

P-500 1:50@A3

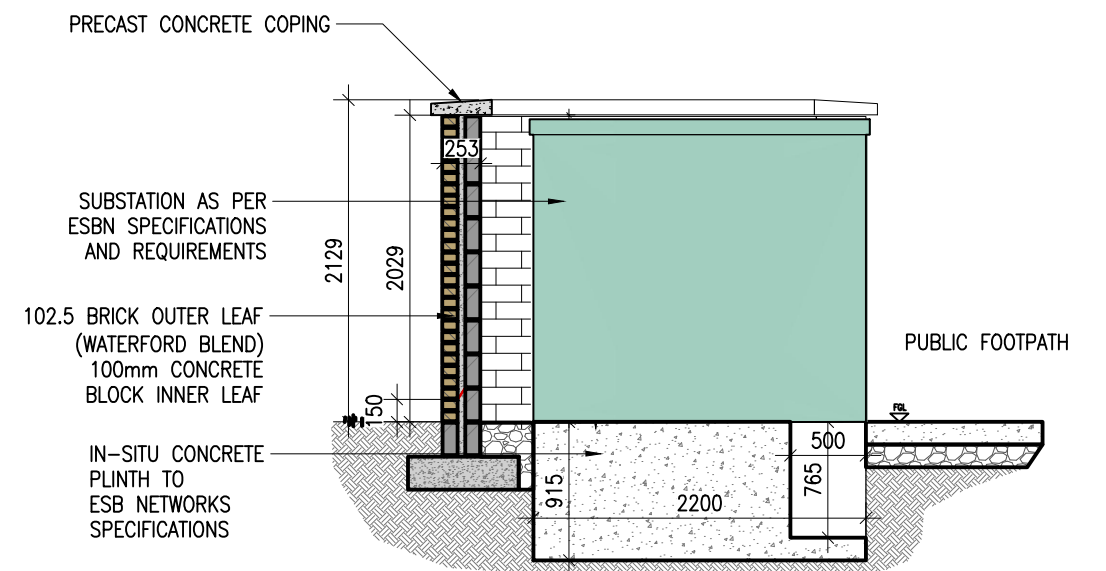

3 ESB Substation - Section AA

P-500 1:50@A3

No.	Date	Revision	Initials
01	09/11/23	Draft Issue For Discussion	ED
02	23/11/23	Part 8 Issue	ED

M:\Project Section - Current\6168A Kilcarbery Residential Extension\CAD\Drawings\Planning\Titlesheets\6168A Water, Bin, Bike Stores, Meter Walls.dwg 23/11/2023 10:47:09

Project		RESIDENTIAL DEVELOPMENT AT UPPER NANGOR ROAD, KILCARBERY, CO. DUBLIN		6-7 HARGOURT TERRACE, DUBLIN 2, IRELAND t +353-1-618 2400 f +353-1-676 7305 e architecture@bkd.ie www.bkd.ie	
Drawing Title		ESB SUBSTATION			
Drawing No		6168A-P-500			
Scale	1:50@A3	Rev	02		
		Date	23/11/23		

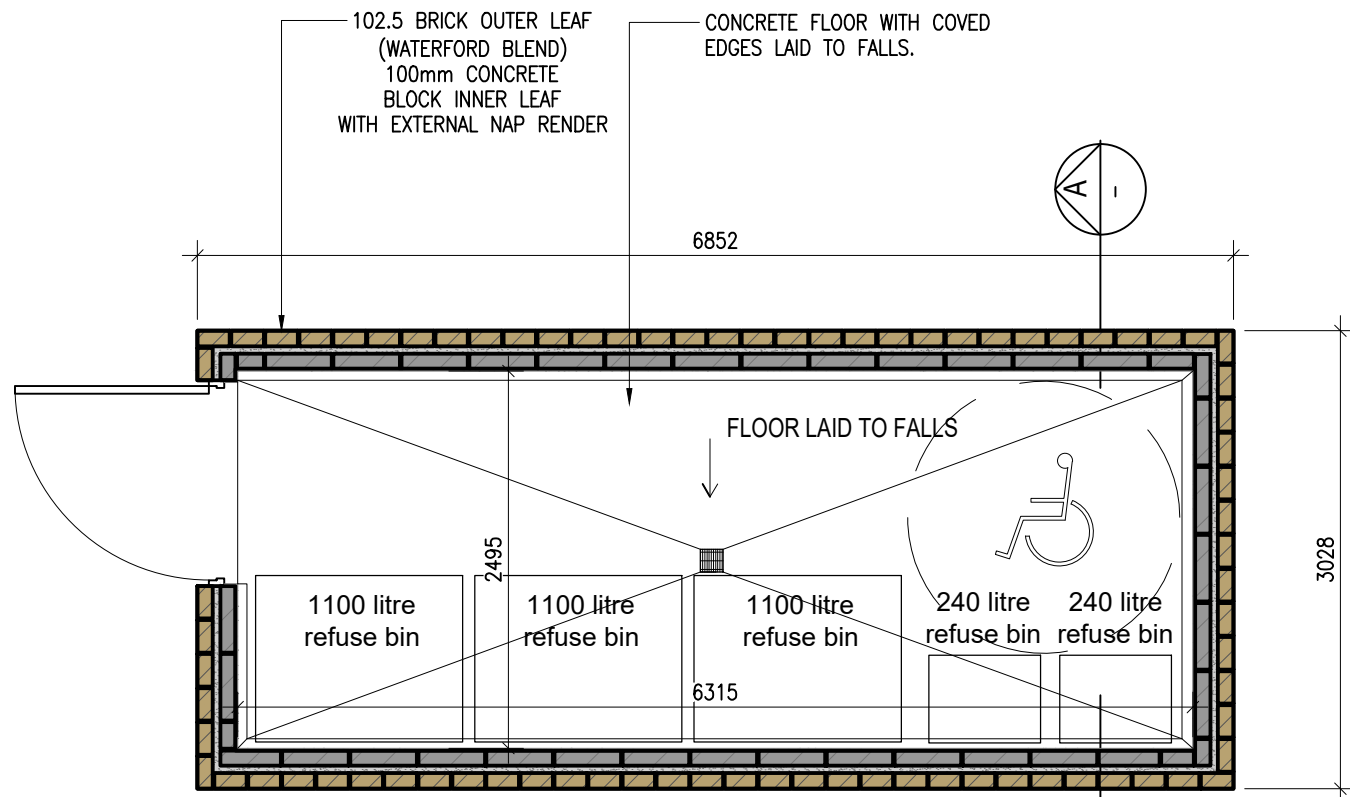

1 Bin Store - Plan
P-501 1:50@A3

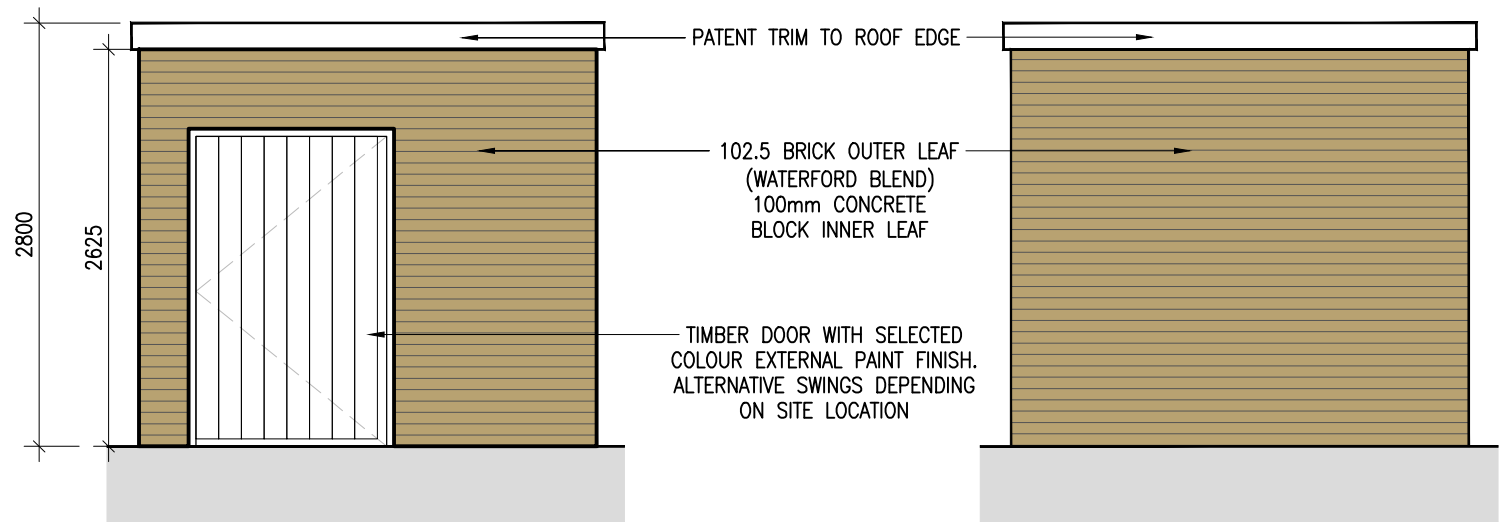

2 Bin Store - Front Elevation
P-501 1:50@A3

3 Bin Store - Rear Elevation
P-501 1:50@A3

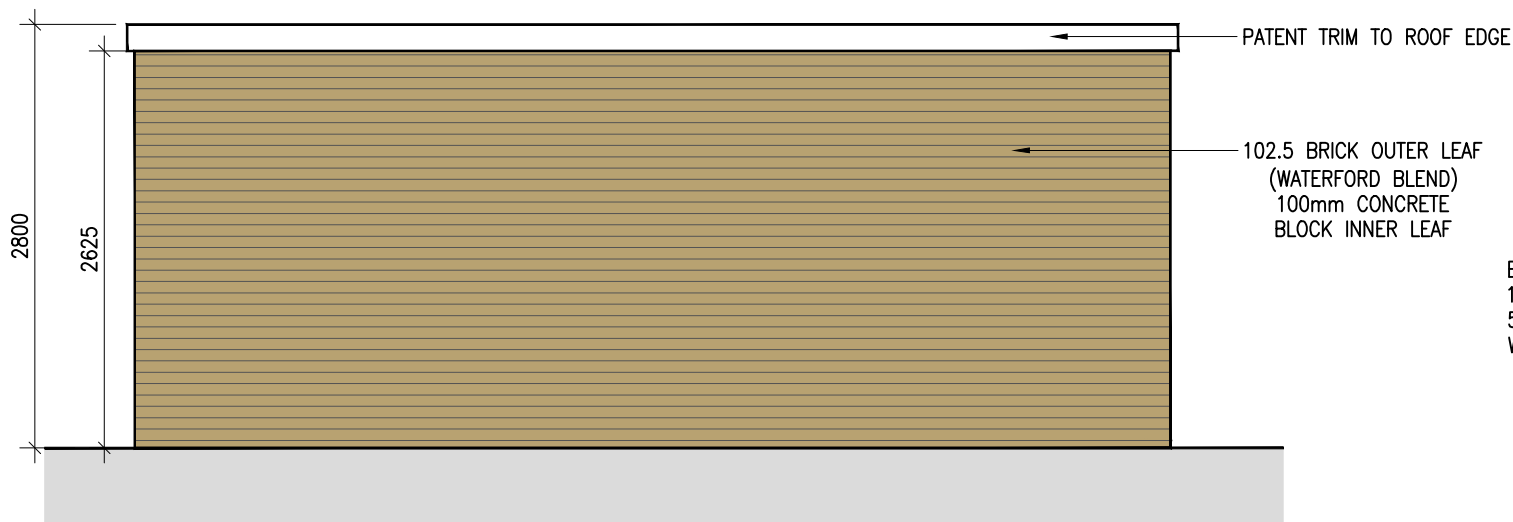

4 Bin Store - Side Elevation
P-501 1:50@A3

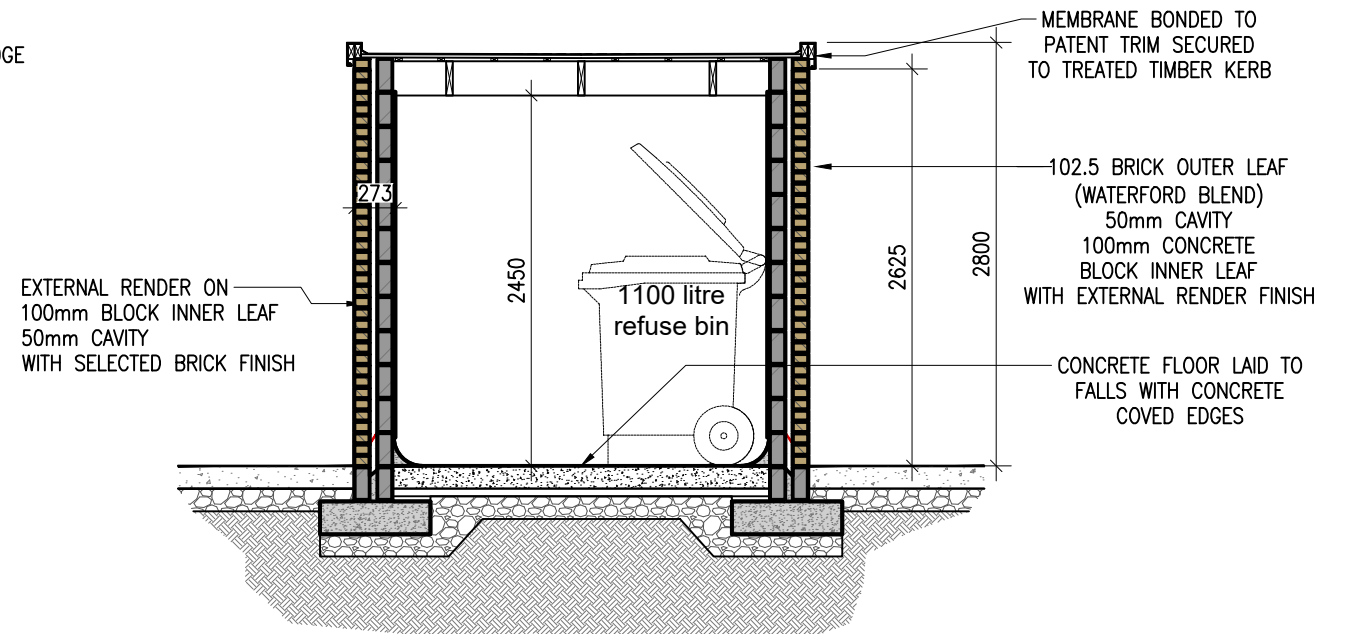

5 Bin Store -Section AA
P-501 1:50@A3

REFER TO SITE PLAN DRAWINGS FOR FLOOR LEVELS OF INDIVIDUAL BIN STORES

No.	Date	Revision	Initials
01	09/11/23	Draft Issue For Discussion	ED
02	23/11/23	Part 8 Issue	ED

M:\Project Section - Current\6168A Kilcarbery Residential Extension\CAD\Drawings\Planning\Titlesheets\6168A Water, Bin, Bike Stores, Meter Walls.dwg 23/11/2023 10:46:32

Project		RESIDENTIAL DEVELOPMENT AT UPPER NANGOR ROAD, KILCARBERY, CO. DUBLIN		6-7 HARCOURT TERRACE, DUBLIN 2, IRELAND t +353-1-618 2400 f +353-1-676 7305 e architecture@bkd.ie www.bkd.ie			
Drawing Title		BIN STORE TYPE 1					
Drawing No		6168A-P-501					
Scale	1:50@A3	Rev	02			Drawn	AS

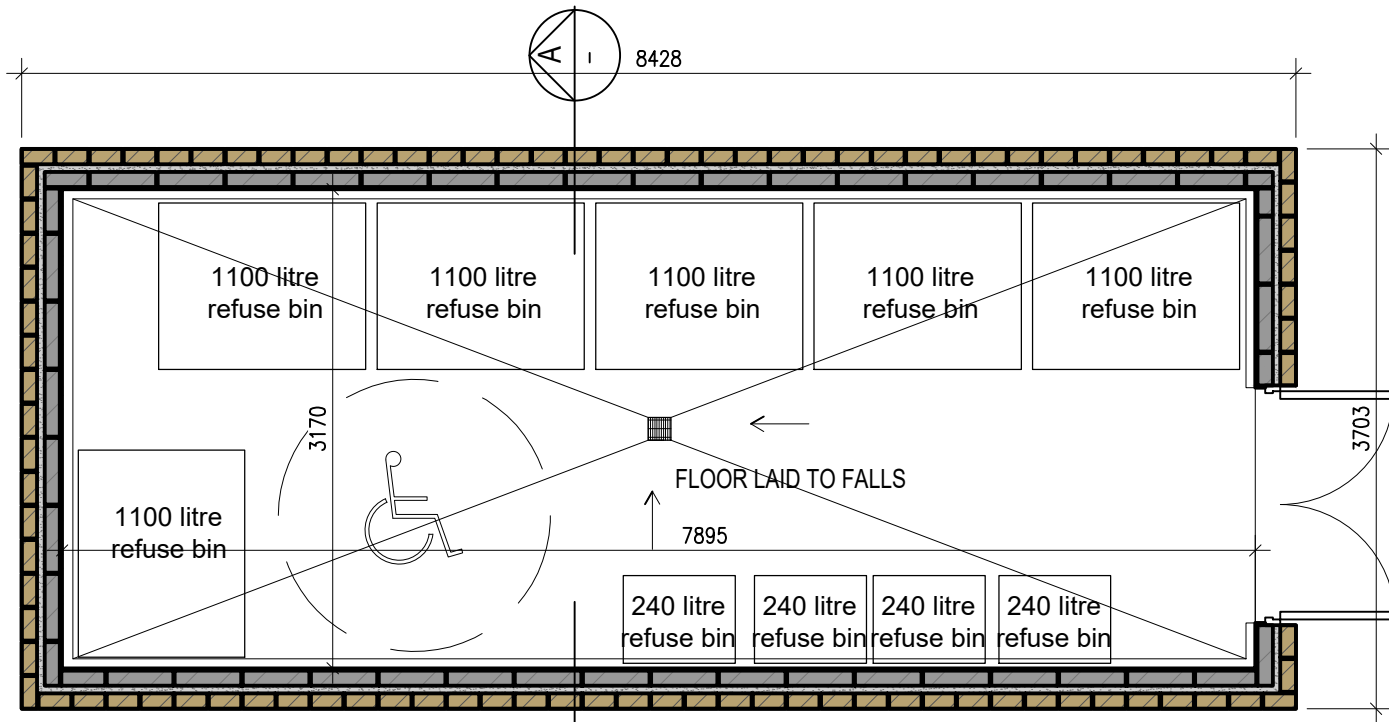

1 Bin Store - Plan

P-502 1:50@A3

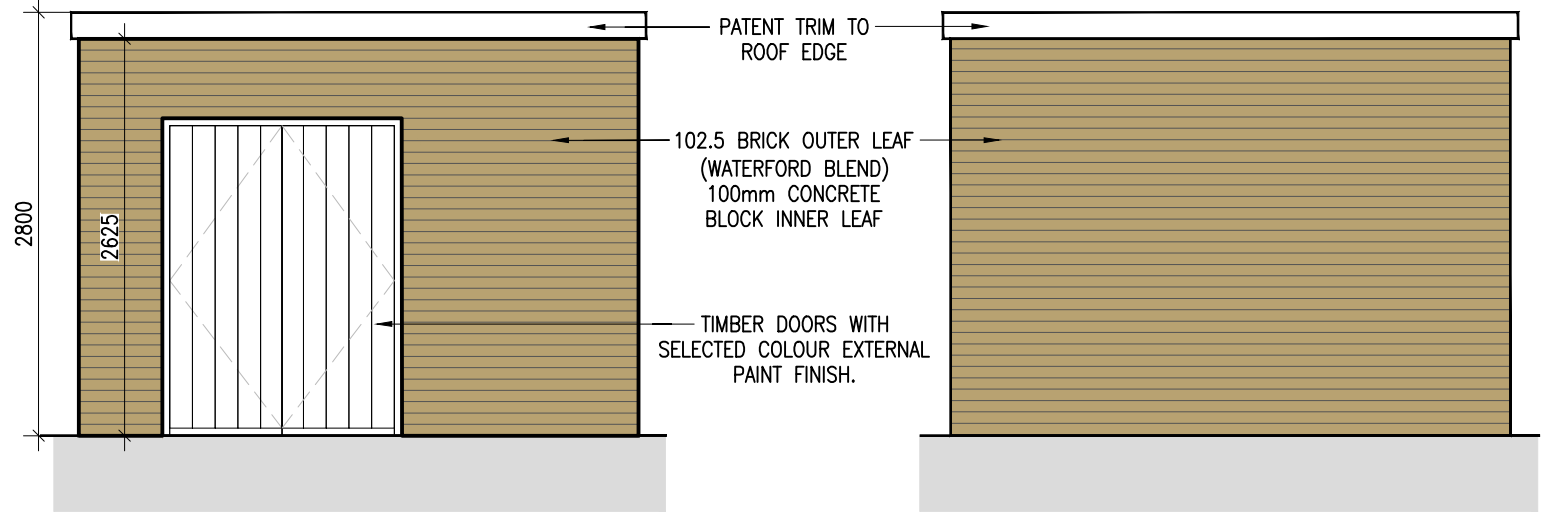

2 Bin Store - Front Elevation

P-502 1:50@A3

3 Bin Store - Rear Elevation

P-502 1:50@A3

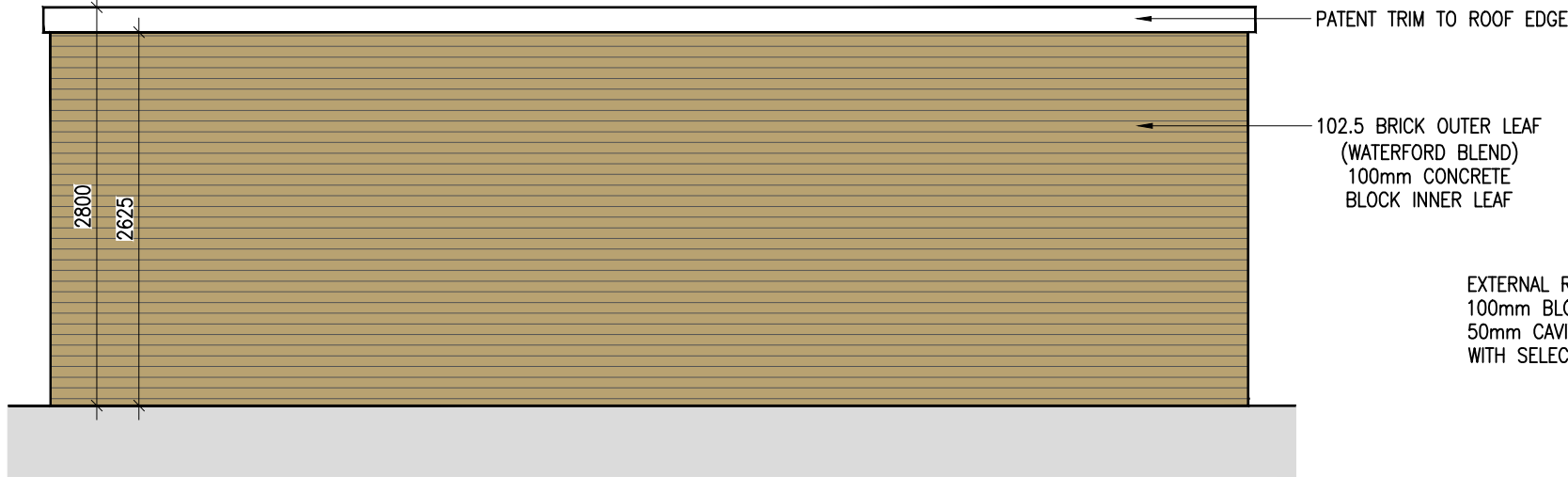

4 Bin Store - Side Elevations

P-502 1:50@A3

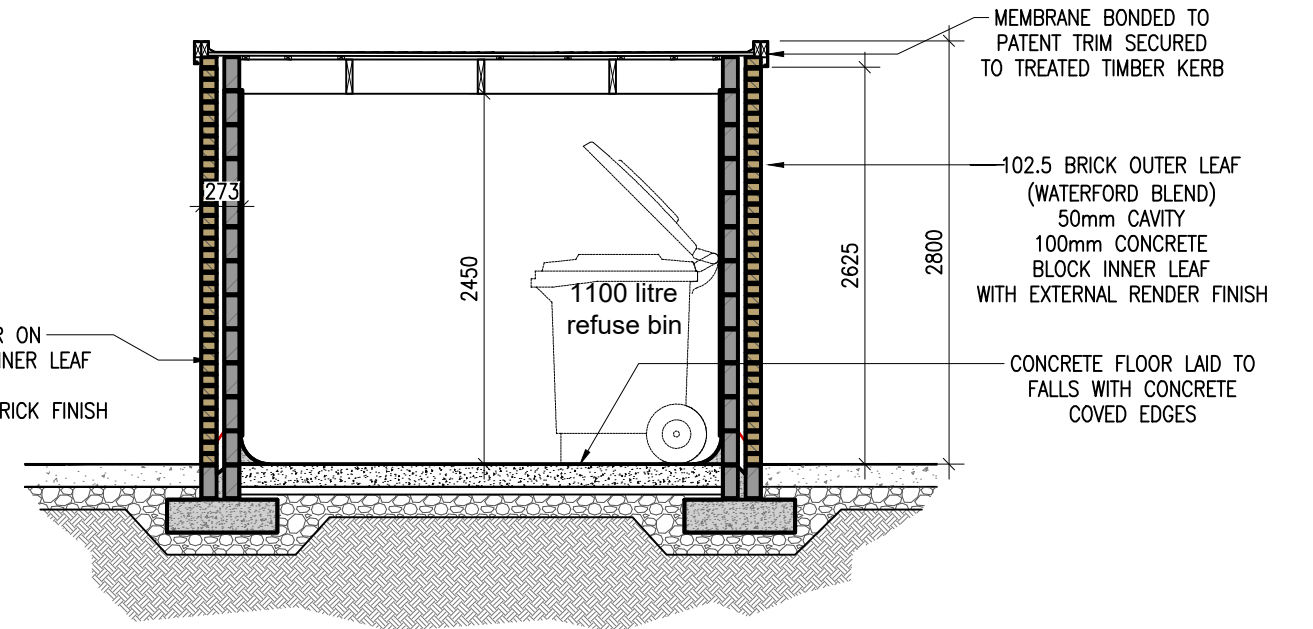

5 Bin Store -Section AA

P-502 1:50@A3

REFER TO SITE PLAN DRAWINGS FOR FLOOR LEVELS OF INDIVIDUAL BIN STORES

No.	Date	Revision	Initials
01	09/11/23	Draft Issue For Discussion	ED
02	23/11/23	Part 8 Issue	ED

Project		RESIDENTIAL DEVELOPMENT AT UPPER NANGOR ROAD, KILCARBERY, CO. DUBLIN		6-7 HARCOURT TERRACE, DUBLIN 2, IRELAND t +353-1-618 2400 f +353-1-676 7305 e architecture@bkd.ie www.bkd.ie			
Drawing Title		BIN STORE TYPE 2		 BURKE-KENNEDY DOYLE			
Drawing No		6168A-P-502					
Scale	1:50@A3	Rev	02			Drawn	AS

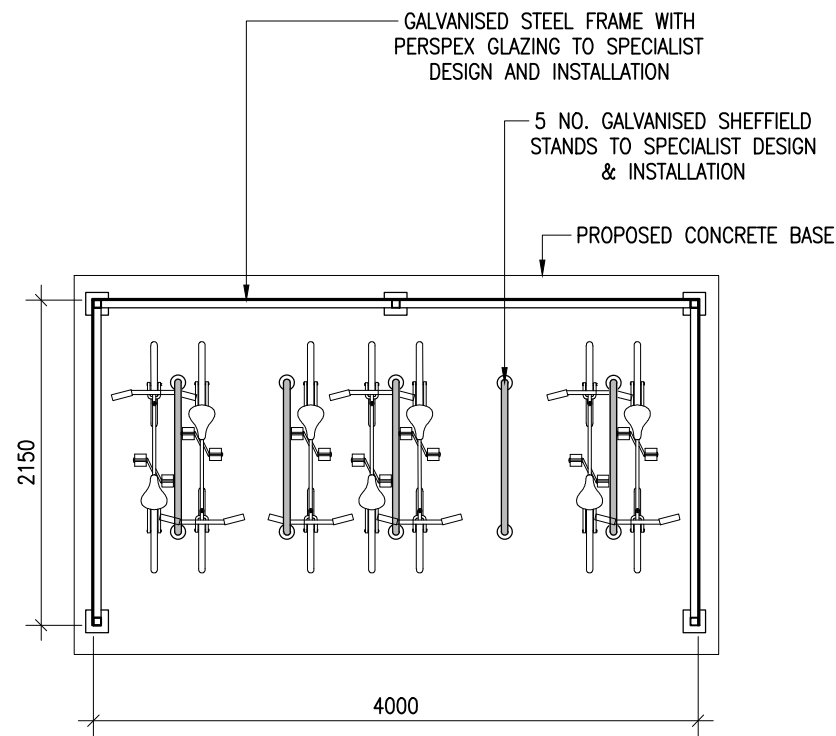

1 Bike Store - Plan
P-503 1:50@A3

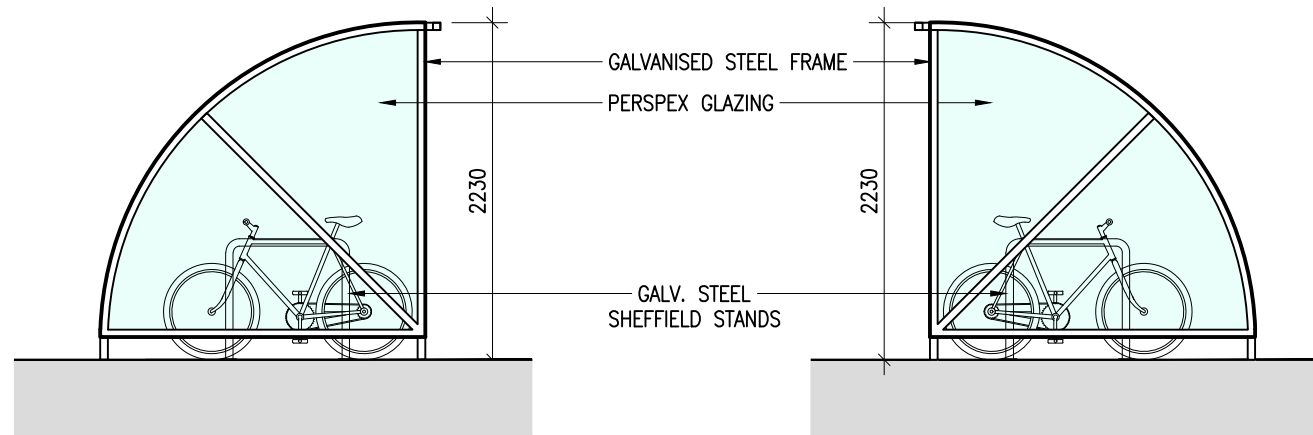

2 Bike Store - Elevation
P-503 1:50@A3

3 Bike Store - Elevation
P-503 1:50@A3

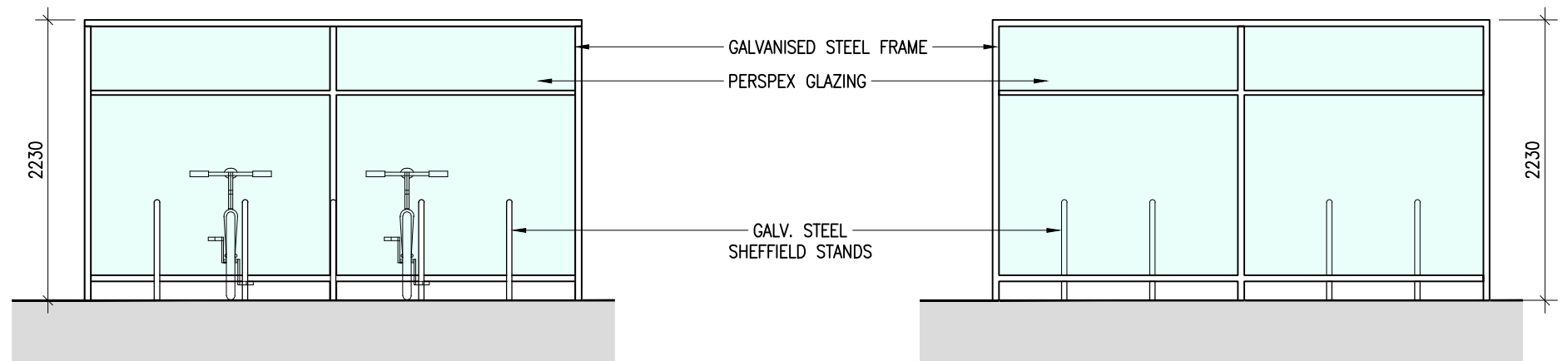

4 Bike Store - Front Elevation
P-503 1:50@A3

5 Bike Store - Rear Elevation
P-503 1:50@A3

REFER TO SITE PLAN DRAWINGS FOR FLOOR LEVELS OF INDIVIDUAL BIKE STORES

No.	Date	Revision	Initials
01	09/11/23	Draft Issue For Discussion	ED
02	23/11/23	Part 8 Issue	ED

Project	RESIDENTIAL DEVELOPMENT AT UPPER NANGOR ROAD, KILCARBERY, CO. DUBLIN		
Drawing Title	BIKE SHELTERS		
Drawing No	6168A-P-503		
Scale	1:50@A3	Rev	02
Drawn	AS	Date	23/11/23

6-7 HARGCOURT TERRACE, DUBLIN 2, IRELAND
t +353-1-618 2400 f +353-1-676 7306
e architecture@bkd.ie
www.bkd.ie

bkdarchitects
BURKE-KENNEDY DOYLE